



Creating healthy spaces
 NV RENSON® Sunprotection-Screens SA

Protect?
 Drainage?
 Confection side?

Quotation

Quotation date	21.12.2022	CP Interiors
Quotation number	20057293	St. Saviour
Customer number	1001334	28 Rue des Pres. Tr. Est.
Your VAT number		JE2 7QN JERSEY
Currency	GBP	JERSEY
Project reference	S013682 COLLIE	
Order reference	SO13682	
Validity from-to	21.12.2022 - 20.01.2023	

Incoterms	DAP Jersey	Delivery address CP Interiors St. Saviour 28 Rue des Pres. Tr. Est. JE2 7QN JERSEY JERSEY
------------------	---------------	---

Overview

Material	Quantity	Net amount	VAT %
001000 CAM2 CAMARGUE	1,00 PC	20.456,44	

Total before VAT	20.456,44
VAT	0,00
Total incl. VAT	20.456,44

Free of VAT, export

PAYMENT INFORMATION

Payment term 30 days end of month

For questions or remarks regarding this document, please send an email to outdoor-uk@renson.be

The General Terms and Conditions of Sale are integral part of our agreement. See Professional Portal at <http://www.renson.eu/>



Creating healthy spaces
 NV RENSON® Sunprotection-Screens SA

Quotation

20057293

21.12.2022

Detail

Item	Material	Unit price	Quantity	Gross amount	Discount %	Net amount
001000	CAM2 CAMARGUE		1,00 PC	34.094,06		20.456,44
	Commodity code	94069090	Prefabricated aluminum buildings, sun protection structures			
	Camargue	16.889,00 GBP /	1 PC x 1,00	16.889,00		
	Camargue Line column	522,00 GBP /	1 PC x 4,00	2.088,00		
	Camargue Line reinforced mounting base	208,00 GBP /	1 PC x 4,00	832,00		
				19.809,00	40	11.885,40
	Integrated Fixscreen	2.183,00 GBP /	1 PC x 2,00	4.366,00		
	Integrated Fixscreen	2.883,00 GBP /	1 PC x 2,00	5.766,00		
				10.132,00	40	6.079,20
	UpDown Led : 2x Up White	1.782,00 GBP /	1 PC x 1,00	1.782,00		
	UpDown Led : 2x Up White	1.782,00 GBP /	1 PC x 1,00	1.782,00		
				3.564,00	40	2.138,40
	Rain sensor	236,86 GBP /	1 PC x 1,00	236,86		
	Situo 5 IO VAR Pure II - 5-channel transmitter	154,20 GBP /	1 PC x 1,00	154,20		
	Tahoma	198,00 GBP /	1 PC x 1,00	198,00		
				589,06	40	353,44
				14.285,06		8.571,04
	Configuration					
	Structure					
	Type					
	Structure	Single				
	Location					
	Location	Normal wind loads (standard)				
	Structure strength	Standard				
	Construction					
	Type					
	Roof part	Roof part 1				
	Dimensions					
	Span	4.000 mm				
	Pivot	5.650 mm				
	Passage height	2.300 mm				
	Construction method					
	Span 1	Freestanding				
	Span 2	Freestanding				
	Pivot 1	Freestanding				
	Pivot 2	Freestanding				
	Columns					
	Column type 1A	Corner column				
	Column type 1B	Corner column				
	Column type 2A	Corner column				
	Column type 2B	Corner column				
	Design Styles (TL)					
	Design Styles (SL)					
	Design Style	No				
	Side infills					
	Span 1 (S1)					
	Infill S1	Fixscreen				



Creating healthy spaces

NV RENSON® Sunprotection-Screens SA

Quotation

20057293

21.12.2022

Span 2 (S2)	
Infill S2	Fixscreen
Pivot 1 (P1)	
Infill P1	Fixscreen
Pivot 2 (P2)	
Infill P2	Fixscreen
General specifications	
Infill height Fixscreen	Passage height
Comfort	
Lighting	
Position UpDown led	P1, P2, S1, S2
Color led 'UP'	Warm white
Automation	
Country of installation	United Kingdom
Motor control	Somfy IO
Renson Connect App	Yes
Frost/Snow function	No
Transmitter	Situo 5 VAR IO Pure
Rain sensor	Ceramic rain sensor
Voltage motor	230V
Electrical certification	CE (Standard)
Is there a Tahoma account	No
Styling	
Colors	
Color type frame and columns	Textured
Color code frame and columns	029/73223-TIGER RAL7006 FINE TEXTURE
Color type of roof blades	Matt
Color of roof blades	AE300C9900120-AXALTA RAL9001 MATT
Type of fabrics	
Type of fabric Fixscreen	Fibreglass fabric Sergé
Fabric code Fixscreen	FG-SC2050 LINEN-DARK GREEN
Confection side	Confection side 1
Technical specs	
General	
Motor position	Pivot 1 (P1)
Blade rotation	Indirect sunlight
Columns	
Mounting base 1A	Invisible reinforced
Mounting holes in the col. 1A	Yes
Direction of water drainage 1A	Pivot
Height water drainage 1A	66 mm
Mounting base 1B	Invisible reinforced
Mounting holes in the col. 1B	Yes
Water drainage direction 1B	Pivot
Height water drainage 1B	66 mm
Mounting base 2A	Invisible reinforced
Mounting holes in the col. 2A	Yes
Water drainage direction 2A	Pivot
Height water drainage 2A	66 mm
Mounting base 2B	Invisible reinforced
Mounting holes in the col. 2B	Yes
Water drainage direction 2B	Pivot
Height water drainage 2B	66 mm



Creating healthy spaces
NV Renson® Sunprotection-Screens SA

Quotation

20057293

21.12.2022

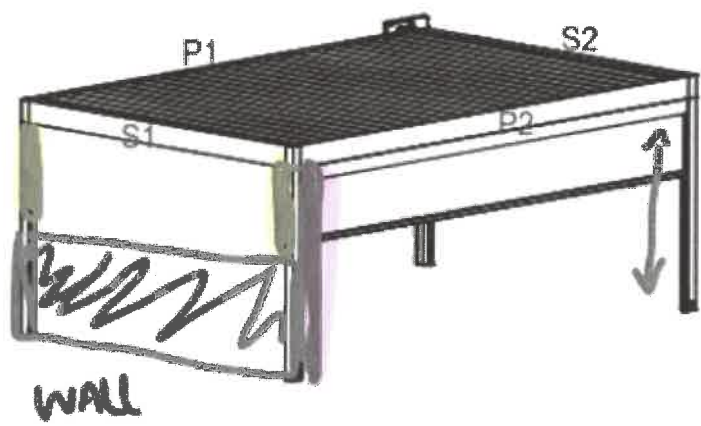

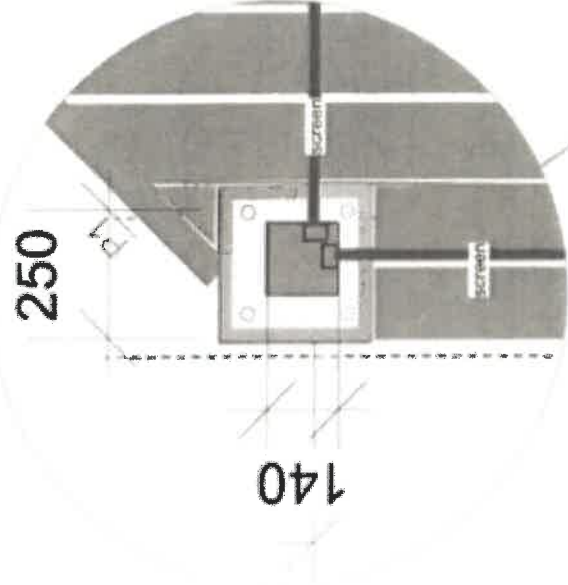

Wiggle room
10-20 mm??

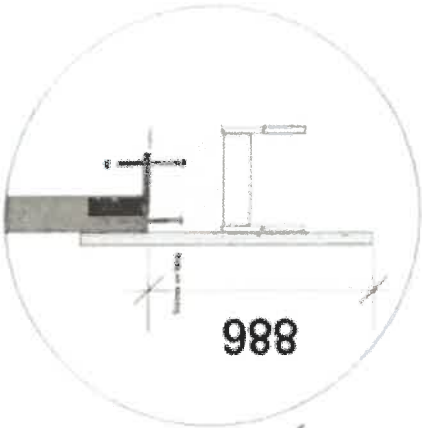

Section B

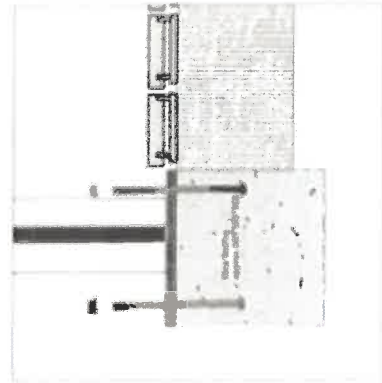
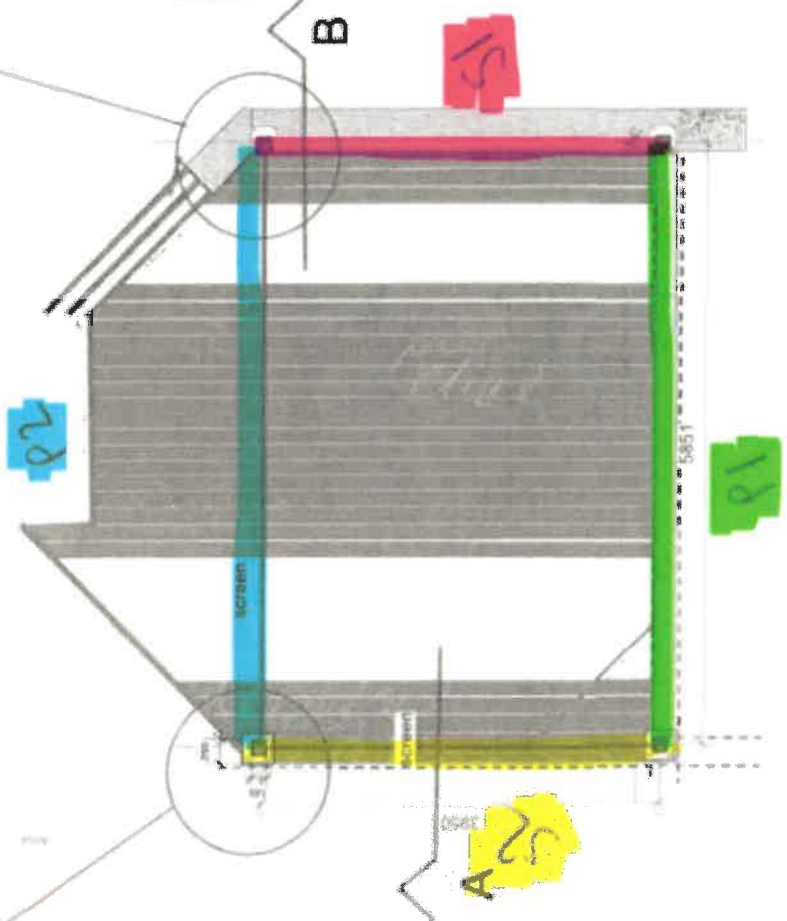

Section A

Rachel Allo

From: Rachel Allo
Sent: 30 November 2022 11:44
To: Harris Collie
Subject: RE: Quotation ref SO13682

2100 / 2200 / 2300 ✓

Good morning Harris,

I am working with Renson on your proposed project and just wanted you to make clear a few things if possible please to get you a more accurate proposal.

I have labelled **P2/S1/P1/S2** (which refers to our pivot and span lengths) and am going to use these as easy reference points or my questions.

- 1) could you please confirm which sides you would like the up lighting quoted on? All 4 sides or just 2 sides for example P1 and P2 or vice versa S1 and S2?
- 2) P1 – is this greyed out area also a wall or is it the side of the house? 891.
- 3) S1 – could you please confirm for me the height of the low wall and subsequently if you have a maximum height to work towards. The portal will require what they call a negative overlength which essentially would be the passage height minus the wall height. Passage height is the calculation from the floor to the underside of the top beam (allow +260mm on top of this to the top side of the framework).
- 4) In my second drawing (please note colours do not coordinate with previous) the red area is the wall, the two green posts are the original posts from S1 which will sit on the wall and the blue column is an additional post which will allow the screen to drop down full length to the floor on side P2.

Look forward to hearing from you,

Kind regards

Rachel

Rachel Allo
Interior Design Advisor
rachel@cpinteriors.ie



Tel: (01534) 768141 www.cpinteriors.ie
Rue Des Pres Trading Estate, St Saviour, Jersey, JE2 7QP

Blinds | Curtains | Awnings | Shutters | Furnishings |
Interior Design | Project Management



CP INTERIORS

December 01,2022

REF : SO13682

Mr. Harris Collie
Old Quarry House
Oaklands Lane
St Helier
JE2 4JD

Dear Mr. Harris Collie

As requested, we have pleasure in submitting our quotation for the following.

Description	QTY	Price
To Supply and Fit ,Bladed Roof Systems, Renson Camargue, with 4 columns, electric operation of louvres. Somfy smart home operation (via mobile devices and voice control), plus hand held control. Powder coated in colour of your choice (TBC). Includes rain sensor Size: 3950mm span x 5851mm pivot x 2.45m complete height, Passage Height 2.2m	1	£ 30,638.00
To Supply, Optional fix screens, integrated within the unit to single span and pivot side in a serge fabric to be decided,	2	£ 7,175.00
To Supply, Optional Warm White UP lighting to both span and both pivot sides S1/S2/P1/P2,	1	£ 4,277.00
Subtotal :		£ 42,090.00
GST :		£ 2,104.50
Total :		£ 44,194.50

., excludes electrical works,

Please note these structure are designed as garden rooms and as such may not be completely water tight. As with all our custom orders, we require a deposit of 40% at the time of placing your order, 40% on delivery to the Island and 20% balance on completion. All prices are subject to GST.

Our Price Promise to you, we will beat any written quotation by 5% (on equivalent specification).

Thank you for your enquiry and we hope you will find this quotation acceptable. Should you require any further information, please contact us.

Yours sincerely
Rachel

To accept the above quotation, please indicate which option is required, sign below and return this letter together with your deposit. Please note extract of our terms and conditions below.

.....
SIGNATURE

.....
DATE

Please note: This quotation is only valid for acceptance for 7 days. Our estimate does not include any electrical work or additional carpentry work to install the above unless otherwise specified. Please note there is a handling charge on customer own fabric of £5 per metre. Due to high costs of labour, pre-arranged missed fitting appointments will be charged on a time-wasted basis. Settlement is due on completion of works and an administration charge of £25 will be added per month if unpaid within 30 days. We reserve the right to charge for design, advice and liaison work carried out should an order not be placed. Goods remain the property of CP Interiors until full settlement is received. Should payment not be received we reserve the right to attend premises during working hours to remove goods and not be required to make good. Our full terms and conditions apply and are available on request.

As we no longer accept cheques, please do:

- Call us and pay by Card, we accept card transactions over the telephone and we will not charge you a handling fee.
- Bank details: Natwest, Sort Code 60-12-03, Account No 66577772 Carpet Protection (C.I) Ltd T/A CP Interiors

If you pay your deposit by BACS payment, please confirm the details of your order by returning a signed copy of this letter

Tel : (01534) 768141

www.cpinteriors.ie

Rue des Pres Trading Estate, St Saviour, Jersey, JE2 7QN

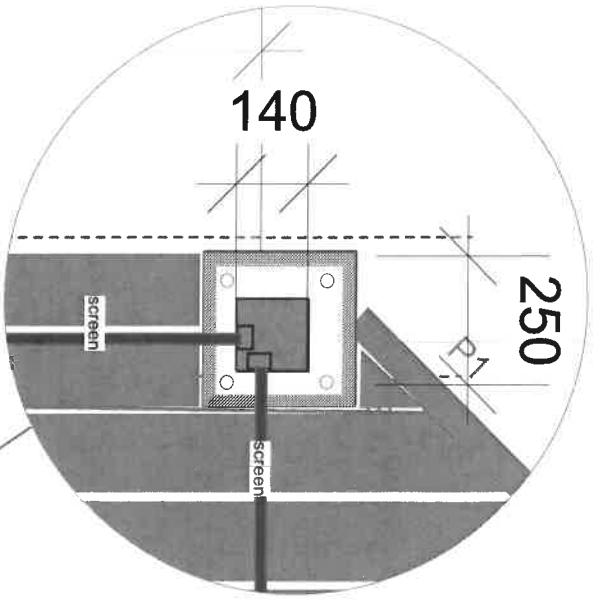

Wiggle room
10-20 mm??

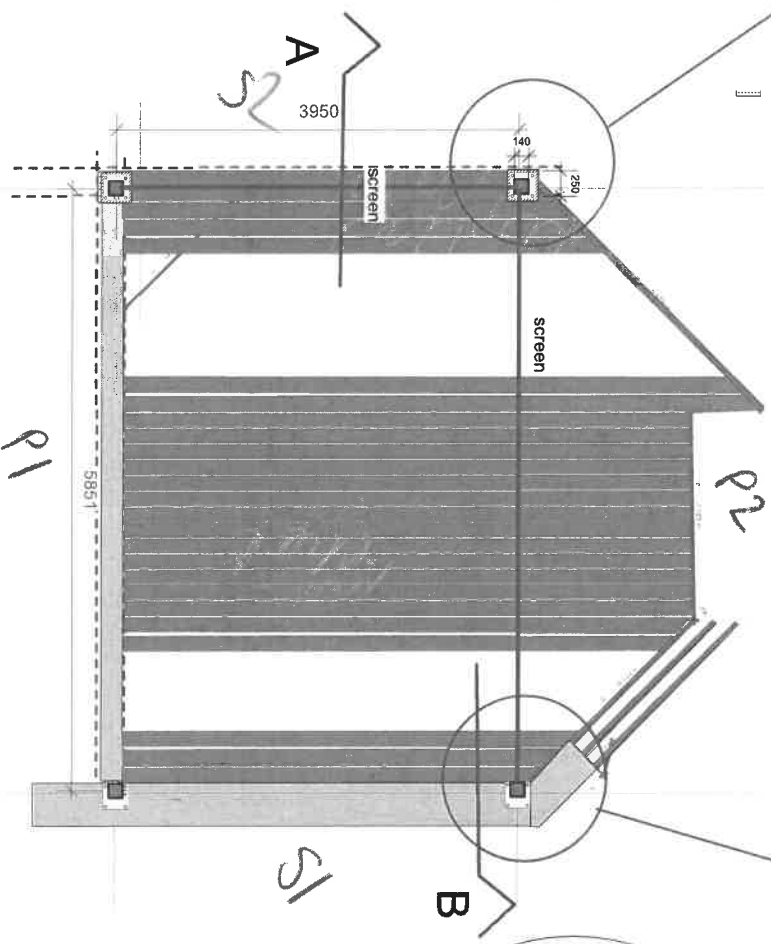
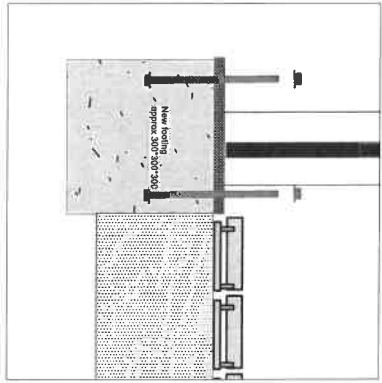
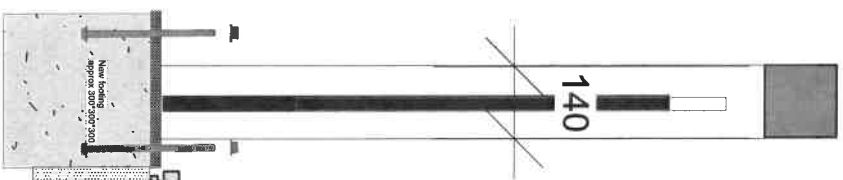
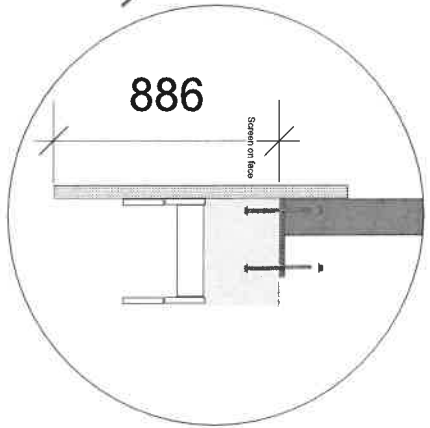
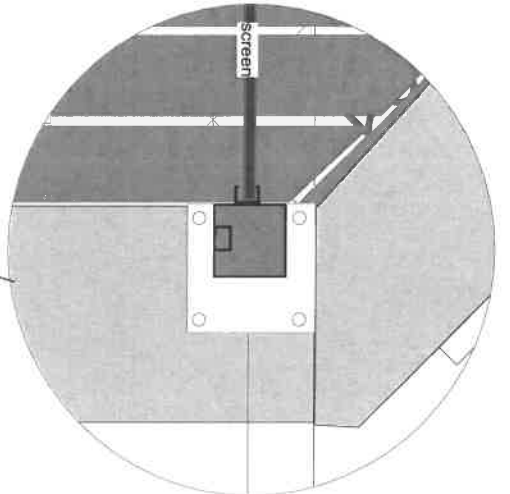

Section A

Section B

It was 4500*6055 it is now 3950* 5851.

Could this mean a reduced price?

I need to get a revised price so I can get thinking about putting down the deposit

I am trying to get the area prepared as the current decking is being replaced and slightly altered.

I need work out the details of the footings which I will need to put in, for the base plates.

I am hoping they will start in January but that could drift.

I need to come down your way and can come and to see you anytime this week, if you can tell me when is convenient.

Kind Regards,

Harris

On 18 Nov 2022, at 11:10, Leeana Taft <Leeana@cpinteriors.je> wrote:

Great, look forward to it

Leeana Taft
Director

<image001.jpg>

Tel: (01534) 768141 www.cpinteriors.je
Rue Des Pres Trading Estate, St Saviour, Jersey, JE2 7QP

Blinds | Curtains | Awnings | Shutters | Furnishings |
Interior Design | Project Management

From: Harris Collie <harriscollie@googlemail.com>

Sent: 18 November 2022 11:05

To: Leeana Taft <Leeana@cpinteriors.je>

Subject: Re: Quotation ref SO13682

Hi,

I will come around sometime after 2 today

Harris

On 18 Nov 2022, at 09:12, Leeana Taft <Leeana@cpinteriors.je> wrote:

Good morning

Rachel Allo

From: Leeana Taft
Sent: 29 November 2022 10:57
To: Harris Collie
Cc: Rachel Allo
Subject: RE: Quotation ref SO13682
Attachments: Camargue - mounting bases & water drainage - english.pdf

Hi

That is good news.

Yes, the side screens come in different colour fabrics.

I have attached the Camargue mounting plate options. As discussed the Camargue is the system where the side screen blinds are within the main structure.

Let us have a look at your new dimensions and we can price based on this.

We can get the quotation to you this week, so that when you come in we can run through the complete details.

Kind regards

Leeana Taft
Director



Tel: (01534) 768141 www.cpinteriors.ie
Rue Des Pres Trading Estate, St Saviour, Jersey, JE2 7QP

Blinds | Curtains | Awnings | Shutters | Furnishings |
Interior Design | Project Management

From: Harris Collie <harriscollie@googlemail.com>
Sent: 29 November 2022 10:12
To: Leeana Taft <Leeana@cpinteriors.je>
Subject: Re: Quotation ref SO13682

Dear Leeana,

I came to see you a few weeks ago, I have now got planning permission from my wife and want to push ahead.

Her main question was if the screens come in arrange of colours, do they?

I am attaching a drawing of how I imagine it could work, the overall size is now smaller than the previous quote.



December 01, 2022

REF : SO13682

Mr. Harris Collie
Old Quarry House
Oaklands Lane
St Helier
JE2 4JD

Dear Mr. Harris Collie

As requested, we have pleasure in submitting our quotation for the following.

Description	QTY	Price
To Supply and Fit ,Bladed Roof Systems, Renson Algarve, with 4 columns, electric operation of louvres. Somfy smart home operation (via mobile devices and voice control), plus hand held control. Powder coated in colour of your choice (TBC). Includes rain sensor. Size: 3950mm span x 5851mm pivot x 2.45m complete height, Passage Height 2.2m	1	£ 24,705.00
To Supply, Optional fix screens, retrofitted to single span and pivot side in a serge fabric to be decided,	2	£ 6,381.00
To Supply, Optional Warm White UP lighting to both span and both pivot sides S1/S2/P1/P2,	1	£ 4,277.00
., excludes electrical works,		
Subtotal :		£ 35,363.00
GST :		£ 1,768.15
Total :		£ 37,131.15

Please note these structure are designed as garden rooms and as such may not be completely water tight. As with all our custom orders, we require a deposit of 40% at the time of placing your order, 40% on delivery to the Island and 20% balance on completion. All prices are subject to GST.

Our Price Promise to you, we will beat any written quotation by 5% (on equivalent specification).

Thank you for your enquiry and we hope you will find this quotation acceptable. Should you require any further information, please contact us.

Yours sincerely
Rachel

To accept the above quotation, please indicate which option is required, sign below and return this letter together with your deposit. Please note extract of our terms and conditions below.

.....
SIGNATURE

.....
DATE

Please note: This quotation is only valid for acceptance for 7 days. Our estimate does not include any electrical work or additional carpentry work to install the above unless otherwise specified. Please note there is a handling charge on customer own fabric of £5 per metre. Due to high costs of labour, pre-arranged missed fitting appointments will be charged on a time-wasted basis. Settlement is due on completion of works and an administration charge of £25 will be added per month if unpaid within 30 days. We reserve the right to charge for design, advice and liaison work carried out should an order not be placed. Goods remain the property of CP Interiors until full settlement is received. Should payment not be received we reserve the right to attend premises during working hours to remove goods and not be required to make good. Our full terms and conditions apply and are available on request.

As we no longer accept cheques, please do:

- Call us and pay by Card, we accept card transactions over the telephone and we will not charge you a handling fee.
- Bank details: Natwest, Sort Code 60-12-03, Account No 66577772 Carpet Protection (C.I) Ltd T/A CP Interiors

If you pay your deposit by BACS payment, please confirm the details of your order by returning a signed copy of this letter

Tel : (01534) 768141

www.cpinteriors.ie

Rue des Pres Trading Estate, St Saviour, Jersey, JE2 7QN

Blinds | Curtains | Awnings | Shutters | Furnishings | Interior Design | Project Management

@ Camouflage
 @ 2x Blinds/Screens
 @ Uplight only

1x 1800mm Skender. = Maybe continue down
 Side of wall?
 - Send drawings on Reel, if you
 interested



CP INTERIORS

September 30, 2022

Mr. Harris Collie
 Old Quarry House
 Oaklands Lane
 St Helier
 JE2 4JD

REF: SO13682
 Tech. drawings
 of fixings on Reel

Dear Mr. Harris Collie

As requested, we have pleasure in submitting our quotation for the following.

Description	QTY	Price
To Supply and Fit ,Bladed Roof Systems, Renson Algarve, with 4 columns, electric operation of louvres. Somfy smart home operation (via mobile devices and voice control), plus hand held control. Powder coated in colour of your choice (TBC). Includes rain sensor and hand held remote control Size: 4.2m span x 6.05m pivot x 2.45m complete height, Passage Height 2.3m	1	£ 27,315.00
To Supply, Optional fixed panel, fixed louvre full height screen to span side S1 in aluminium or wood finish.	1	£ 6,588.00
To Supply, Optional fixed panel, fixed louvre half height screen to span side S2 in aluminium or wood finish.	1	£ 5,270.00
To Supply, Optional RGB Up, Warm White Down LED to both pivot sides,	1	£ 2,992.00
To Supply, Optional Somfy tahoma switch smart home hub,	1	£ 250.00
.. excludes electrical works.		
	Subtotal :	£ 42,415.00
	GST :	£ 2,120.75
	Total :	£ 44,535.75

Please note these structure are designed as garden rooms and as such may not be completely water tight. As with all our custom orders, we require a deposit of 40% at the time of placing your order, 40% on delivery to the Island and 20% balance on completion. All prices are subject to GST.

Our Price Promise to you, we will beat any written quotation by 5% (on equivalent specification).

Thank you for your enquiry and we hope you will find this quotation acceptable. Should you require any further information, please contact us.

Yours sincerely
Rachel

To accept the above quotation, please indicate which option is required, sign below and return this letter together with your deposit. Please note extract of our terms and conditions below.

SIGNATURE

DATE

* add size of "half height" to notes &
 request quote - they can do lower
 than 1800mm.

Tel : (01534) 768141

www.cpinteriors.je

Rue des Pres Trading Estate, St Saviour, Jersey, JE2 7QN

original size

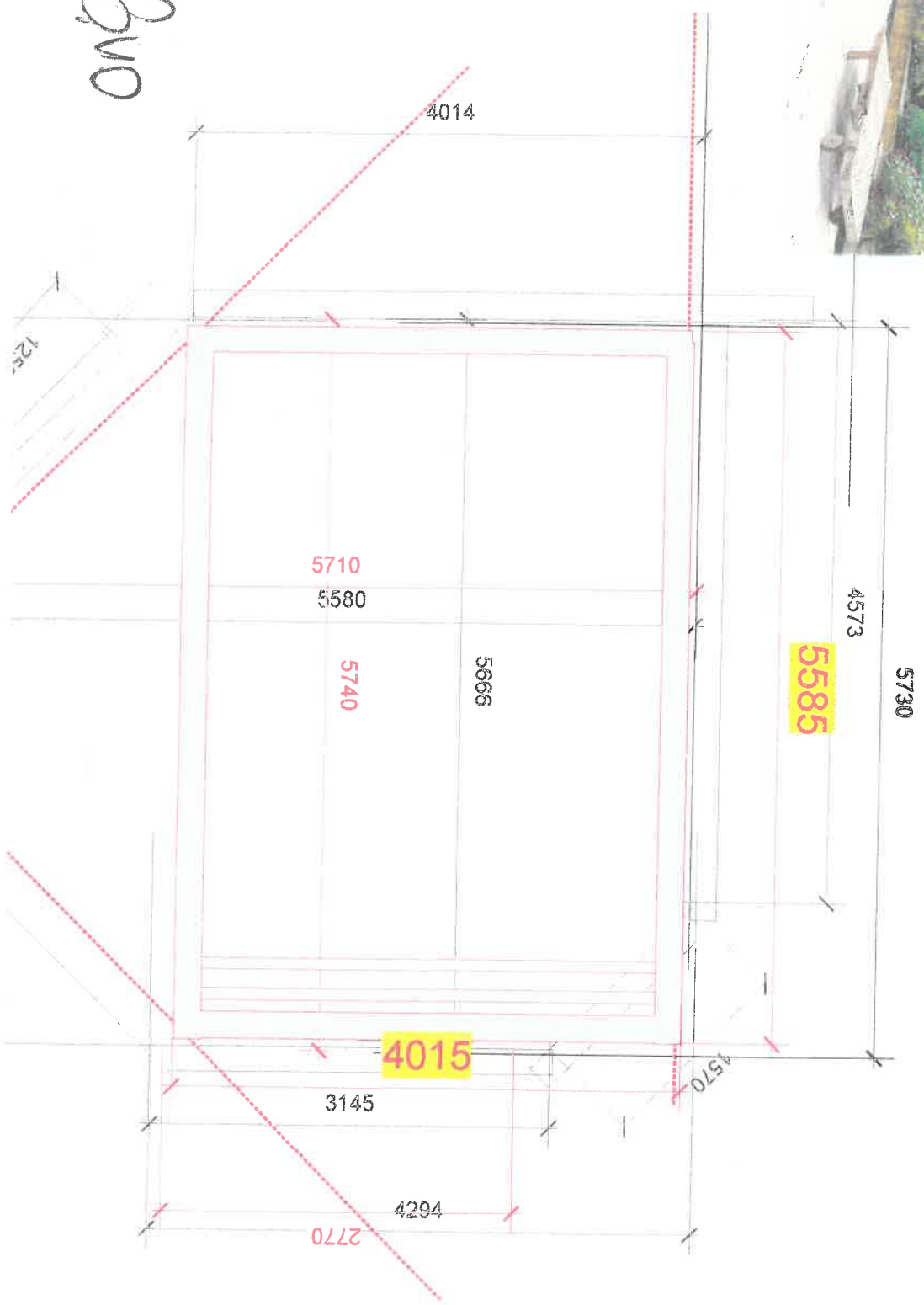

harrisollie@gmail.com

Renson Camargue

height? 2300 based on

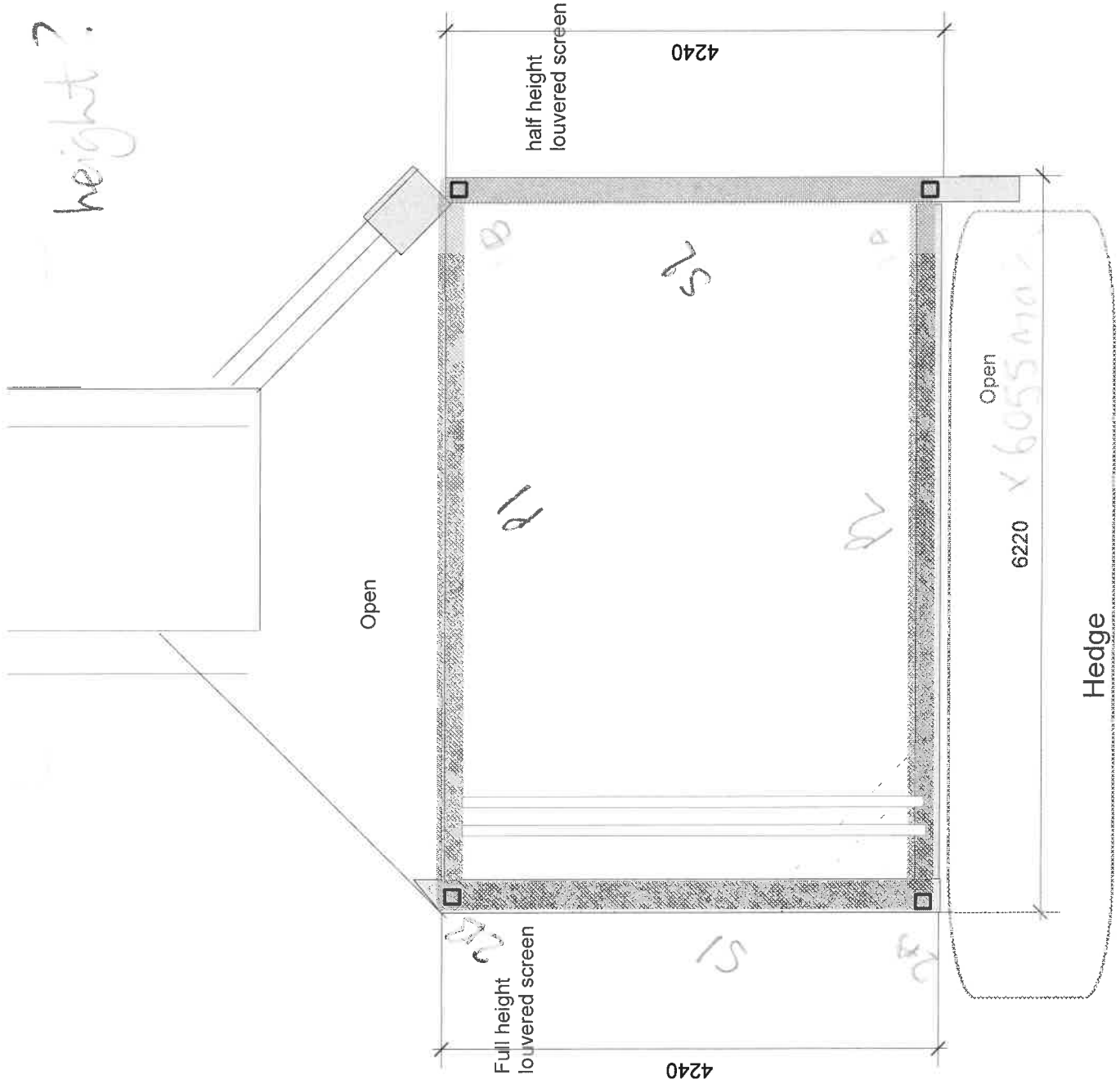

Name	Quantity	Price/piece	Gross price	Discount	Net price (excl. VAT)
Algarve	1	15.845,00 GBP	15.845,00 GBP		
Algarve Line column	4	261,00 GBP	1.044,00 GBP		
Algarve Line reinforced mounting base	4	199,00 GBP	796,00 GBP		
			17.585,00 EUR	40 %	10.611,00 EUR
Fixed wall Paro	1	3.513,00 GBP	3.513,00 GBP		
Fixed wall Paro	1	4.392,00 GBP	4.392,00 GBP		
			7.905,00 EUR	40 %	4.743,00 EUR
UpDown Led : 2x Up RGB + Down White	1	2.493,00 GBP	2.493,00 GBP		
			2.493,00 EUR	40 %	1.495,80 EUR
Rain sensor	1	236,86 GBP	236,86 GBP		
Situo 5 IO Pure II - 5-channel transmitter	1	90,32 GBP	90,32 GBP		
Tahoma	1	198,00 GBP	198,00 GBP		
			525,18 EUR	40 %	315,11 EUR

⑥ 5269,5
6588

27315.

2243,70

Depending on the phase you are in you have received a quote or an order drawing. The quote drawing is a standard drawing based on a standard configuration. Any remarks and/or attachments are not visible on the quote drawing. In the order drawings integrate as much as possible any remarks and/or attachments. Remark: *... items that can not be integrated in the order drawing will be considered wh... order goes in production.*

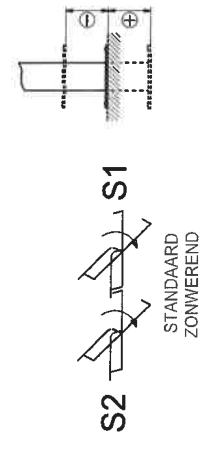
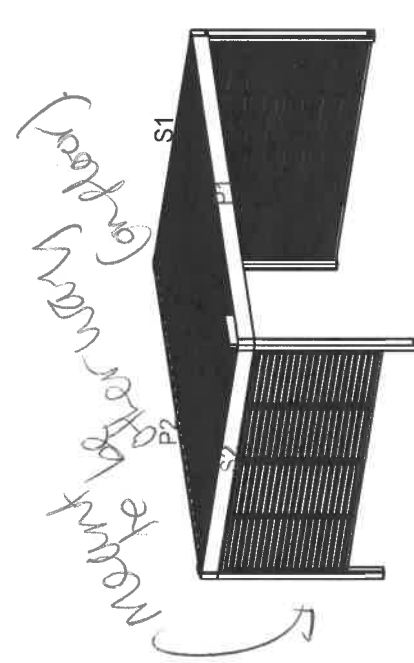
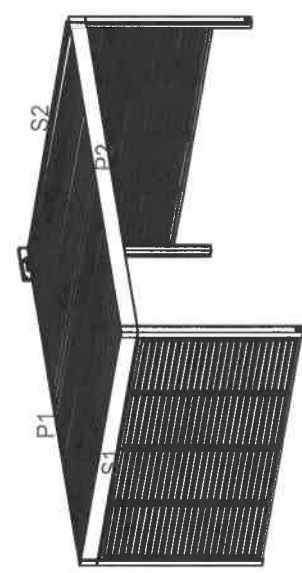
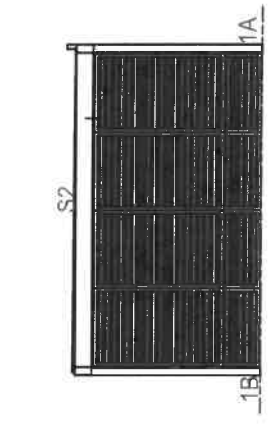
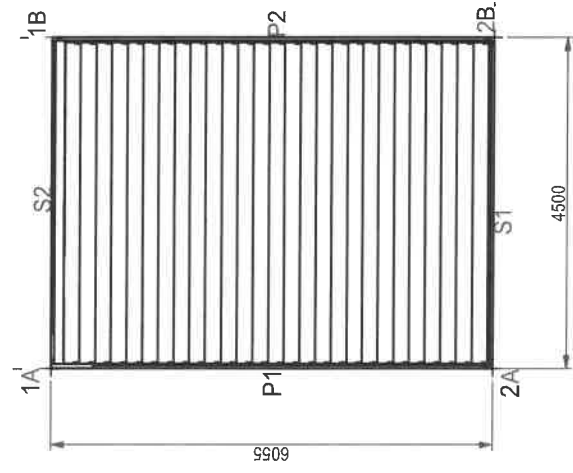
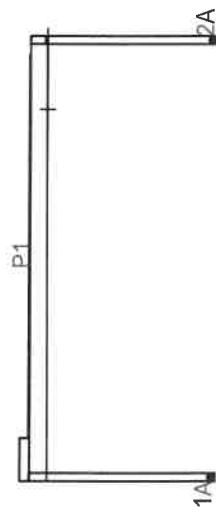
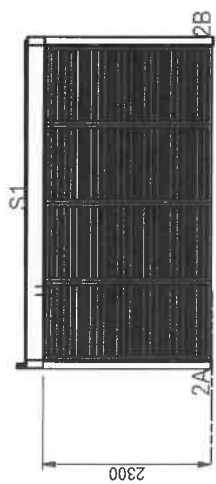
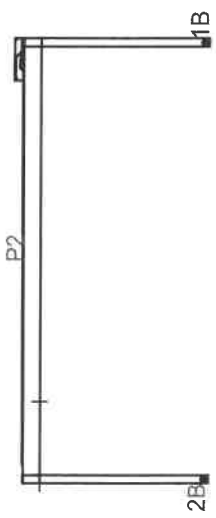

- 1A = 0
- 2A = 0
- 1B = 0
- 2B = 0
- P1 = 0
- P2 = 0
- S1 = 0
- S2 = 0

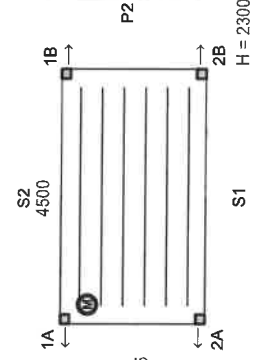

<p>RENSON Creating healthy spaces</p> <p><small>www.renon.nl • 8700 Wieringen (Belgium)</small> <small>This is a technical drawing. It is not intended for reproduction or to be used in third parties without written permission.</small></p>	Client Reference :	Sheet : 1 / 1
	Orderline ref. : 20051088001000.110052	Scale : 1 : 1
Client :	Creation date : 28/09/2022 - 13:55:17	Drawn : autoh0c09
	Color :	Size : A3
		units in mm

20051088001000.110052_Algarve3_configurator