

**WINDOW REFERENCES:**

**W1, W2 & W3**

Overall Area	- 1.45m <sup>2</sup>
Openable Area	- 0.84m <sup>2</sup>
U-Value	- 1.6w/m <sup>2</sup> K
Frame Type	- Timber
Openable Angle	- > 30°
Trickle Vent	- N/A
No. Required	- 3

NOTE: PLEASE REFER TO ELEVATIONS FOR HANDING OF WINDOW AND DOOR SWINGS

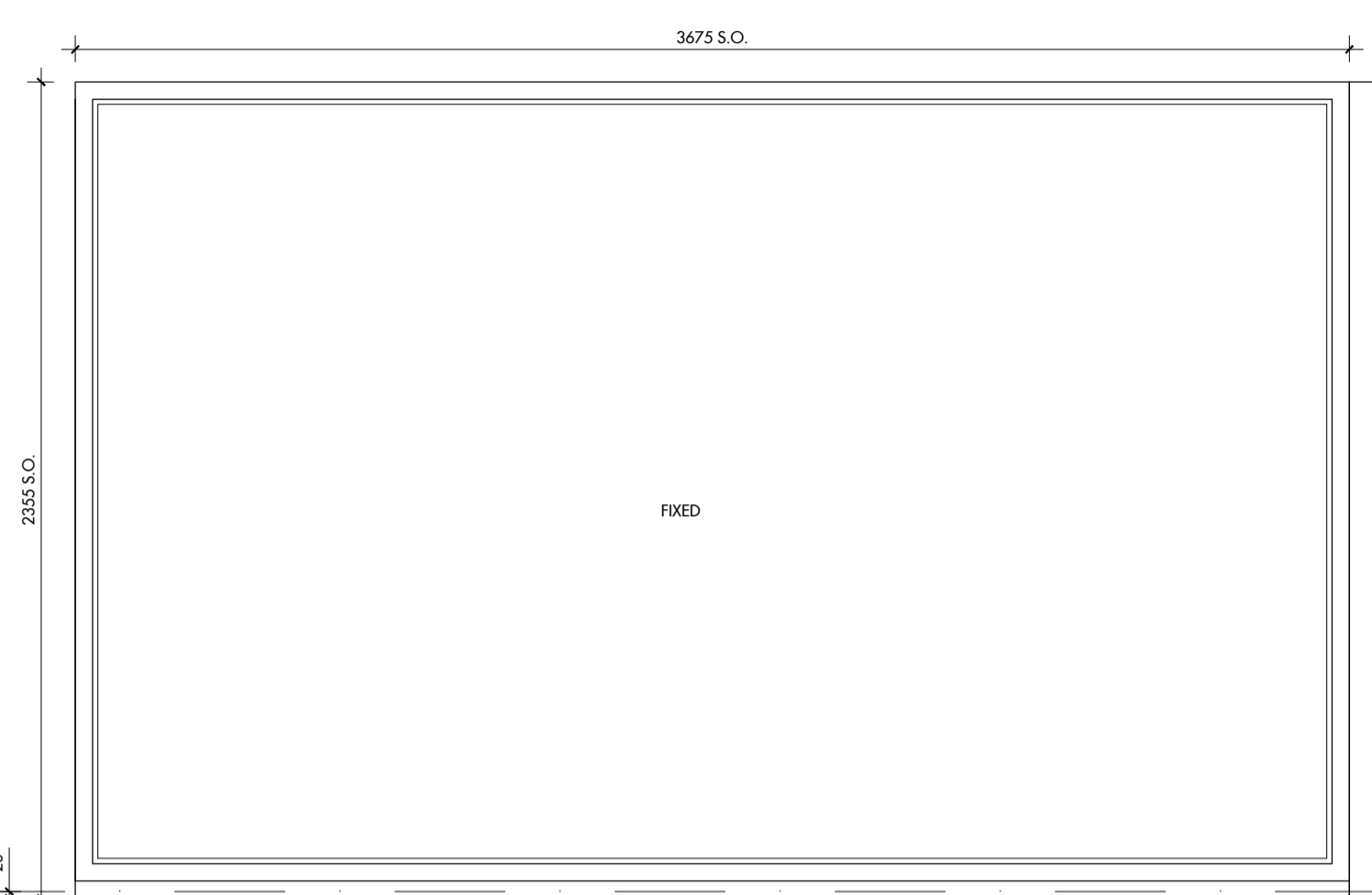

**WINDOW REFERENCES:**

**W4**

Overall Area	- 8.65m <sup>2</sup>
Openable Area	- N/A
U-Value	- 1.6w/m <sup>2</sup> K
Frame Type	- Aluminium
Openable Angle	- N/A
Trickle Vent	- N/A
No. Required	- 1

NOTE: PLEASE REFER TO ELEVATIONS FOR HANDING OF WINDOW AND DOOR SWINGS

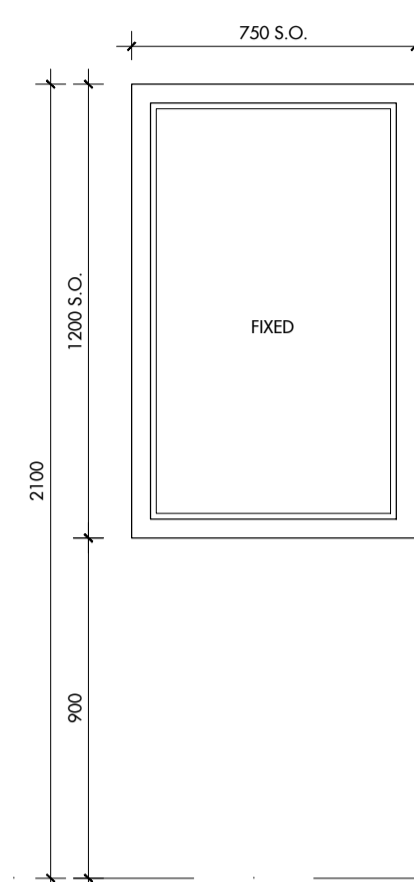

**WINDOW REFERENCES:**

**W5**

Overall Area	- 0.9m <sup>2</sup>
Openable Area	- N/A
U-Value	- 1.6w/m <sup>2</sup> K
Frame Type	- Aluminium
Openable Angle	- N/A
Trickle Vent	- N/A
No. Required	- 1

NOTE: PLEASE REFER TO ELEVATIONS FOR HANDING OF WINDOW AND DOOR SWINGS

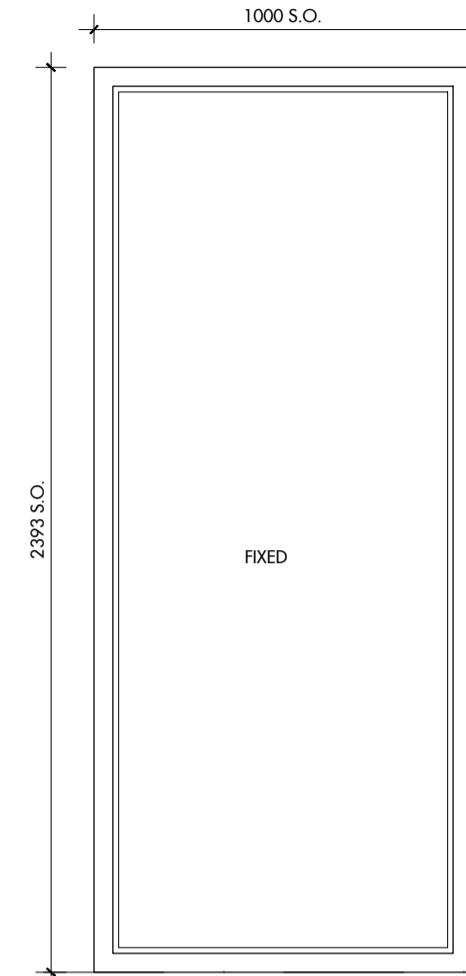

**WINDOW REFERENCES:**

**W6**

Overall Area	- 2.39m <sup>2</sup>
Openable Area	- N/A
U-Value	- 1.6w/m <sup>2</sup> K
Frame Type	- Aluminium
Openable Angle	- N/A
Trickle Vent	- N/A
No. Required	- 1

NOTE: PLEASE REFER TO ELEVATIONS FOR HANDING OF WINDOW AND DOOR SWINGS

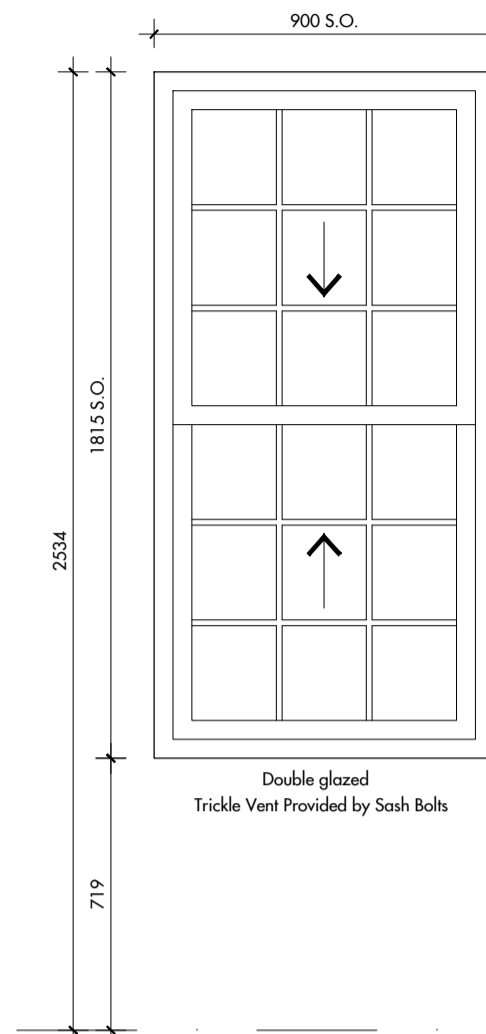

**WINDOW REFERENCES:**

**W7**

Overall Area	- 1.63m <sup>2</sup>
Openable Area	- 0.66m <sup>2</sup>
U-Value	- 1.6w/m <sup>2</sup> K
Frame Type	- Timber
Openable Angle	- > 30°
Trickle Vent	- 4000mm <sup>2</sup>
No. Required	- 1

NOTE: PLEASE REFER TO ELEVATIONS FOR HANDING OF WINDOW AND DOOR SWINGS

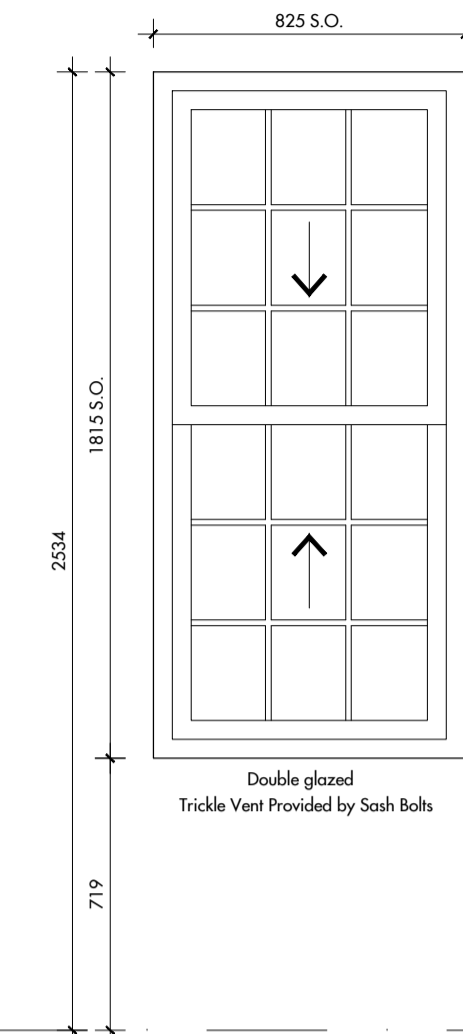

**WINDOW REFERENCES:**

**W8 & W9**

Overall Area	- 1.49m <sup>2</sup>
Openable Area	- 0.60m <sup>2</sup>
U-Value	- 1.6w/m <sup>2</sup> K
Frame Type	- Timber
Openable Angle	- > 30°
Trickle Vent	- 4000mm <sup>2</sup>
No. Required	- 2

NOTE: PLEASE REFER TO ELEVATIONS FOR HANDING OF WINDOW AND DOOR SWINGS

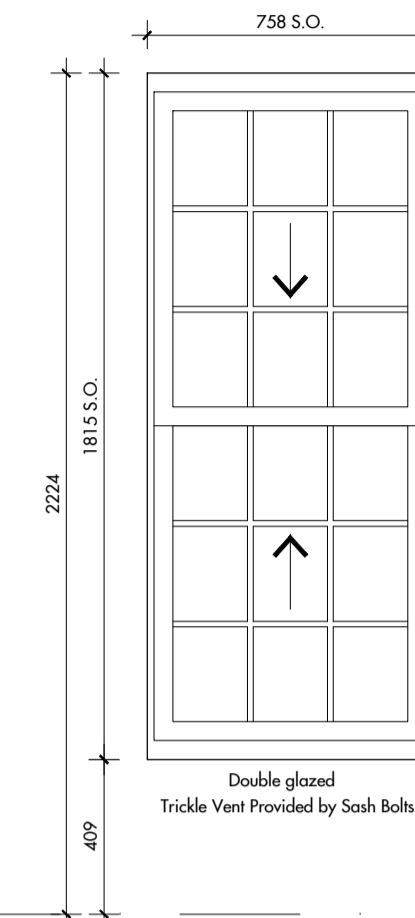

**WINDOW REFERENCES:**

**W10 & W11**

Overall Area	- 1.37m <sup>2</sup>
Openable Area	- 0.60m <sup>2</sup>
U-Value	- 1.6w/m <sup>2</sup> K
Frame Type	- Timber
Openable Angle	- > 30°
Trickle Vent	- 4000mm <sup>2</sup>
No. Required	- 2

NOTE: PLEASE REFER TO ELEVATIONS FOR HANDING OF WINDOW AND DOOR SWINGS

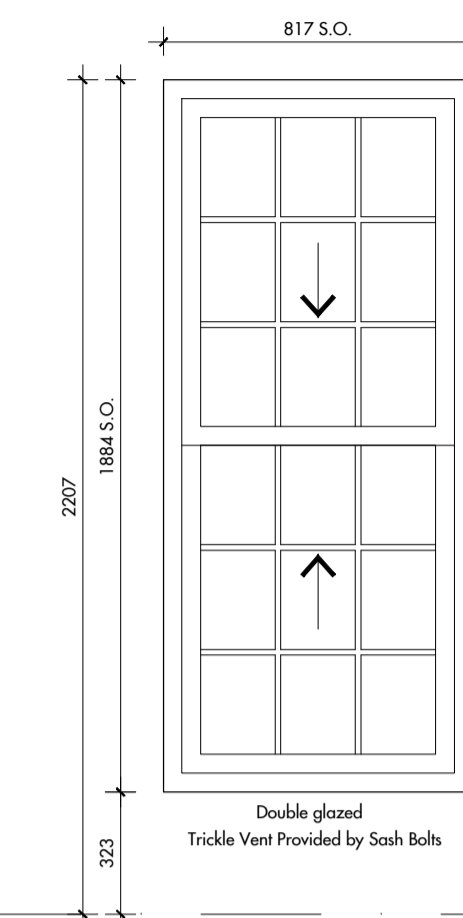

**WINDOW REFERENCES:**

**W12 & W13**

Overall Area	- 1.53m <sup>2</sup>
Openable Area	- 0.62m <sup>2</sup>
U-Value	- 1.6w/m <sup>2</sup> K
Frame Type	- Timber
Openable Angle	- > 30°
Trickle Vent	- 4000mm <sup>2</sup>
No. Required	- 2

NOTE: PLEASE REFER TO ELEVATIONS FOR HANDING OF WINDOW AND DOOR SWINGS

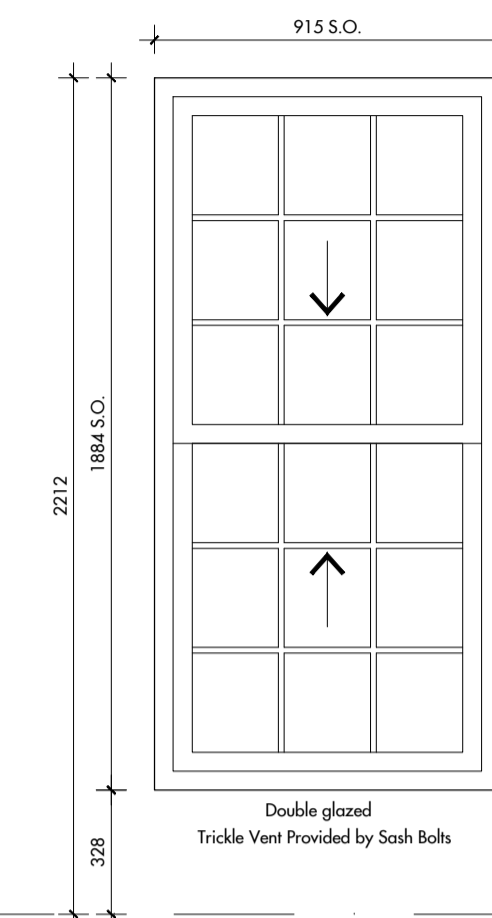

**WINDOW REFERENCES:**

**W14 & W15**

Overall Area	- 1.72m <sup>2</sup>
Openable Area	- 0.70m <sup>2</sup>
U-Value	- 1.6w/m <sup>2</sup> K
Frame Type	- Timber
Openable Angle	- > 30°
Trickle Vent	- 4000mm <sup>2</sup>
No. Required	- 2

NOTE: PLEASE REFER TO ELEVATIONS FOR HANDING OF WINDOW AND DOOR SWINGS

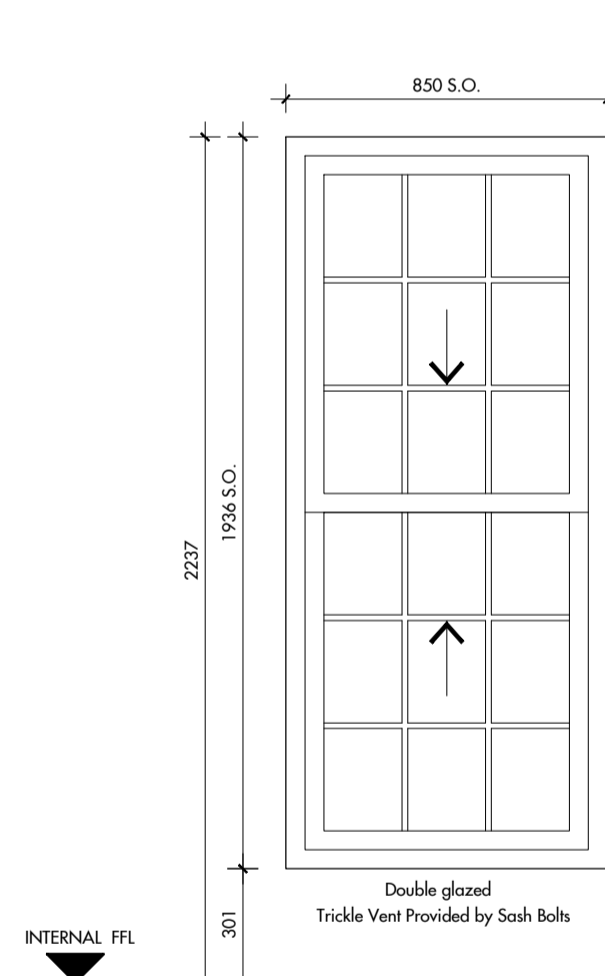

**WINDOW REFERENCES:**

**W16 & W17**

Overall Area	- 1.64m <sup>2</sup>
Openable Area	- 0.66m <sup>2</sup>
U-Value	- 1.6w/m <sup>2</sup> K
Frame Type	- Timber
Openable Angle	- > 30°
Trickle Vent	- 4000mm <sup>2</sup>
No. Required	- 2

NOTE: PLEASE REFER TO ELEVATIONS FOR HANDING OF WINDOW AND DOOR SWINGS



**WINDOW REFERENCES:**

**W18**

Overall Area	- 0.29m <sup>2</sup>
Openable Area	- 0.19m <sup>2</sup>
U-Value	- 1.6w/m <sup>2</sup> K
Frame Type	- Timber
Openable Angle	- > 30°
Trickle Vent	- 4000mm <sup>2</sup>
No. Required	- 1

NOTE: PLEASE REFER TO ELEVATIONS FOR HANDING OF WINDOW AND DOOR SWINGS

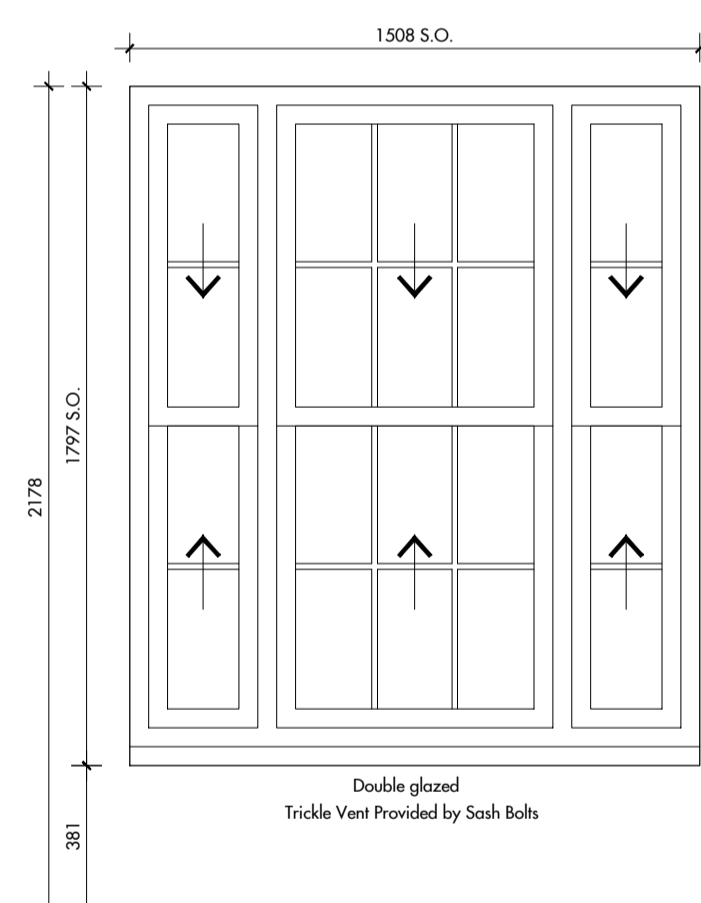

**WINDOW REFERENCES:**

**W19**

Overall Area	- 2.7m <sup>2</sup>
Openable Area	- 1.06m <sup>2</sup>
U-Value	- 1.6w/m <sup>2</sup> K
Frame Type	- Timber
Openable Angle	- > 30°
Trickle Vent	- N/A
No. Required	- 1

NOTE: PLEASE REFER TO ELEVATIONS FOR HANDING OF WINDOW AND DOOR SWINGS

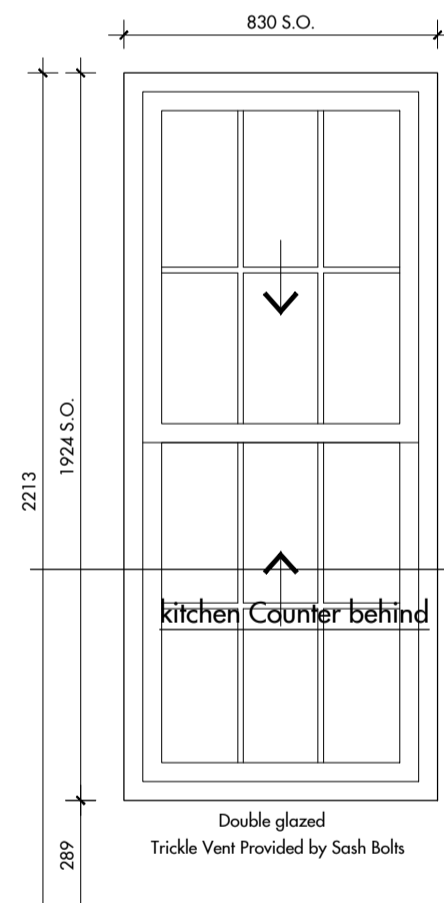

**WINDOW REFERENCES:**

**W20 & W21**

Overall Area	- 1.59m <sup>2</sup>
Openable Area	- 0.65m <sup>2</sup>
U-Value	- 1.6w/m <sup>2</sup> K
Frame Type	- Timber
Openable Angle	- > 30°
Trickle Vent	- 4000mm <sup>2</sup>
No. Required	- 2

NOTE: PLEASE REFER TO ELEVATIONS FOR HANDING OF WINDOW AND DOOR SWINGS

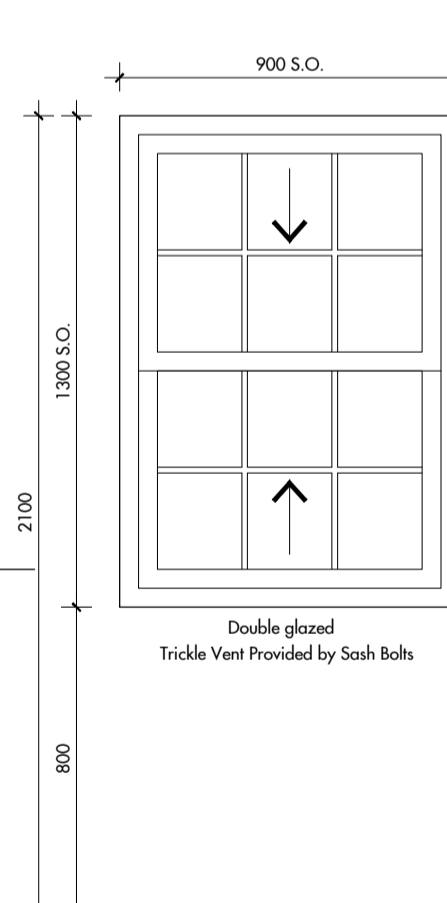

**WINDOW REFERENCES:**

**W22, W23, W24, W25, W26 & W27**

Overall Area	- 1.17m <sup>2</sup>
Openable Area	- 0.46m <sup>2</sup>
U-Value	- 1.6w/m <sup>2</sup> K
Frame Type	- Timber
Openable Angle	- > 30°
Trickle Vent	- 4000mm <sup>2</sup>
No. Required	- 6

NOTE: PLEASE REFER TO ELEVATIONS FOR HANDING OF WINDOW AND DOOR SWINGS

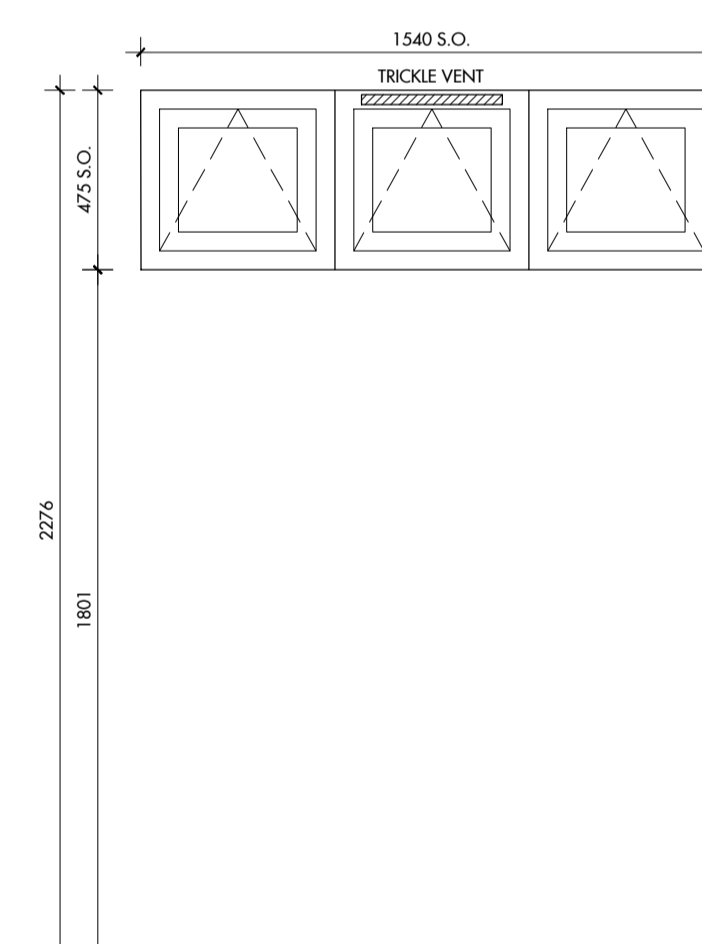

**WINDOW REFERENCES:**

**W28**

Overall Area	- 0.73m <sup>2</sup>
Openable Area	- 0.46m <sup>2</sup>
U-Value	- 1.6w/m <sup>2</sup> K
Frame Type	- Timber
Openable Angle	- > 30°
Trickle Vent	- 4000mm <sup>2</sup>
No. Required	- 1

NOTE: PLEASE REFER TO ELEVATIONS FOR HANDING OF WINDOW AND DOOR SWINGS

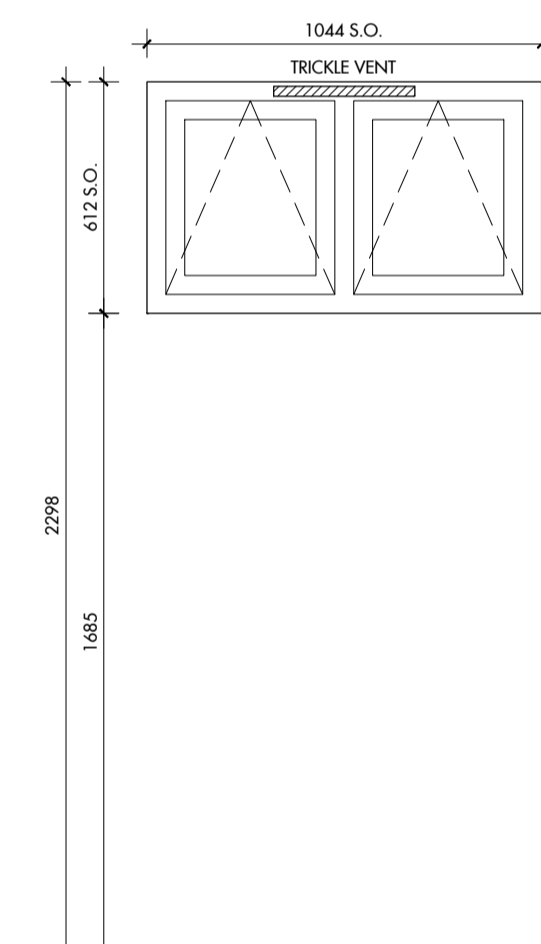

**WINDOW REFERENCES:**

**W29**

Overall Area	- 0.63m <sup>2</sup>
Openable Area	- 0.44m <sup>2</sup>
U-Value	- 1.6w/m <sup>2</sup> K
Frame Type	- Timber
Openable Angle	- > 30°
Trickle Vent	- 4000mm <sup>2</sup>
No. Required	- 1

NOTE: PLEASE REFER TO ELEVATIONS FOR HANDING OF WINDOW AND DOOR SWINGS

**British Standards Requirements:**

BS 6375-1  
Weather tightness

Air Permeability - B EN 12207 - Classification & EN 1026 - Test method

Water resistance - BS EN 12208 - Classification & BS EN 1027 - Test method

Wind Resistance - BS EN 12210 - Classification & BS EN 12211 - Test method

**FULL SITE SURVEY TO BE CARRIED OUT TO ALL EXISTING AND NEWLY FORMED OPENINGS PRIOR TO ORDER OF ANY WINDOWS AND OR DOORS. DIMENSIONS SHOWN ABOVE FOR PRICING AND BUILDING REGULATION PURPOSES ONLY**

- NOTES:**
- All windows to have toughened safety glass as set out in TGD No. 10 Glazing Safety & Protection.
  - Wind loadings & SER requirements as out on Structural Engineer Drawings.
  - Thermal Transmittance U-Value of all window/doors/rooftlights to be 1.6w/m<sup>2</sup>K.
  - All openings to be checked on site prior to manufacture.
  - Unless otherwise stated all units to be Timber framed.
  - All high level opening windows to be opened using electric switch. Power to windows to be allowed for.
  - All windows, doors and rooftlights to be certified under the BFRC (British Fenestration Rating Council) window rating Scheme.
  - Mastic sealant required around front and back of window / door frames over abutment with wall finishes in accordance with TSO DEFRA Robust Details.
  - Window installer to provide a continuous Comriband 600 strip around entire window / door unit sized to suit installed gap size to provide a watertight seal of 600PA and a continuous mastic sealant strip around front and back of window / door frame to seal opening.
  - Minimum Solar factor (g-value) required for windows, doors and rooftlights as follows:
    - Double glazed (air or argon filled) 0.76
    - Double glazed (low-E, hard-coat) 0.72
    - Double glazed (low-E, soft-coat) 0.63
    - Window with secondary glazing 0.76
    - Triple glazed (air or argon filled) 0.68
    - Triple glazed (low-E, hard-coat) 0.64
    - Triple glazed (low-E, soft-coat) 0.57
  - Frame Factors for windows and glazed doors to be as follows:
 

Frame type	Frame factor (proportion of opening that is glazed)
Wood	0.7
Metal	0.8
Metal, thermal break	0.8
PVC-U	0.7

Note:  
Figured dimensions only are to be taken from this drawing. All dimensions are to be checked on site before any work is put in hand. If in doubt, ask.

This drawing must be read in conjunction with all other architects detail drawings, schedules and specifications.

This drawing must not be copied in whole or in part without the prior written permission of MAC architectural Services Ltd.

© Copyright MAC architectural Services Ltd

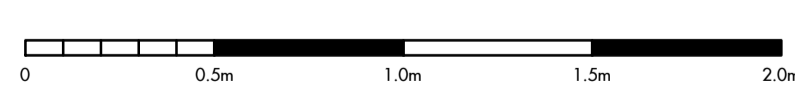

Revision:    Date:    Description:

-	--:--:--	--
---	----------	----

Client:  
**Mr & Mrs Daley**  
Project Address:  
**Le Coin  
Le Mont du Coin  
St. Brelade  
Jersey**

**MAC**  
ARCHITECTURE FOR YOU

22 Hill Street, St. Helier, Jersey JE2 4UA  
www.mac.je / admin@mac.je / 736912

Project:  
**LE COIN**  
Drawing Title:  
**Window Schedule**  
Sheet 1

Scale: 1:20@A1	Date: Nov 2021
Status: BUILDING CONTROL	Drawing No: 817 - 078
	Rev: