

**Vortex**  
**High Tensile Parasol**

**Instructions and  
Safety notices**



**Note: These instructions should be delivered with the parasols and should be retained by the operator.**

**Please ensure that these instructions are read prior to the installation of the parasols or bases.**

**[www.vortexparasols.com](http://www.vortexparasols.com)**

## Table of Contents

Before you start.....	3
Positioning bases .....	3
In-ground base.....	4
Electrical planning .....	4
Electrical supply and conduit through in-ground Base .....	4
Base installation .....	5
In-ground base installation .....	5
Foundations.....	5
Extended in-ground base installation.....	5
Setting into concrete .....	6
Curing of concrete.....	6
Deck plates.....	7
Free-standing bases.....	7
Parasol installation .....	8
Operation.....	12
Opening the parasol .....	12
Closing the parasol.....	17
Short term storage.....	20
Long term storage .....	21
Fitting heaters and lights .....	22
Safety .....	22
Bases.....	23
Moving parasols .....	23
Parasols with electrics.....	24
Heaters .....	24
Product warranty.....	25
Frame warranty.....	25
Canopy warranty .....	25
Modification .....	25
Heaters and lights warranty.....	25
Warranty summary tables.....	25
Ferrari 502 Satin - 10-year limited warranty .....	26
Ferrari 6002 STAM - 5-year limited warranty .....	28
Canopy maintenance and cleaning .....	29
Frame maintenance and cleaning .....	31
Spare parts .....	32
Vortex frame diagram.....	33
Vortex electrical layout schematic .....	33
Vortex circuit diagrams .....	35
Suggested circuit diagram .....	35
5 Core cable circuit diagram .....	36
Retro fit heat and light circuit diagram .....	37

## **Before you start**

Before attempting any installation of the bases or the parasols, please ensure that you have read and understand the instructions fully.

Should you have any questions please contact your supplier for further explanation.

Please note that Vortex Parasols are very heavy (more than 100Kg) and that precautions need to be taken before attempting to move the parasols.

Do not unpack the parasol until the base has been positioned and in the case of the in-ground bases, the concrete allowed to cure fully and you are ready to erect the parasol.

## **Positioning bases**

When positioning the bases please take note of any surrounding walls and overhanging objects.

The edge of the canopy should be no closer than 200mm to the nearest solid object. Positioning the parasol closer than this recommended distance can cause damage to the parasol frame, canopy and any item that the parasol may come into contact with.

When positioning multiple Vortex parasols adjacent to each other there should be a gap of 200mm between the edges of the canopies.

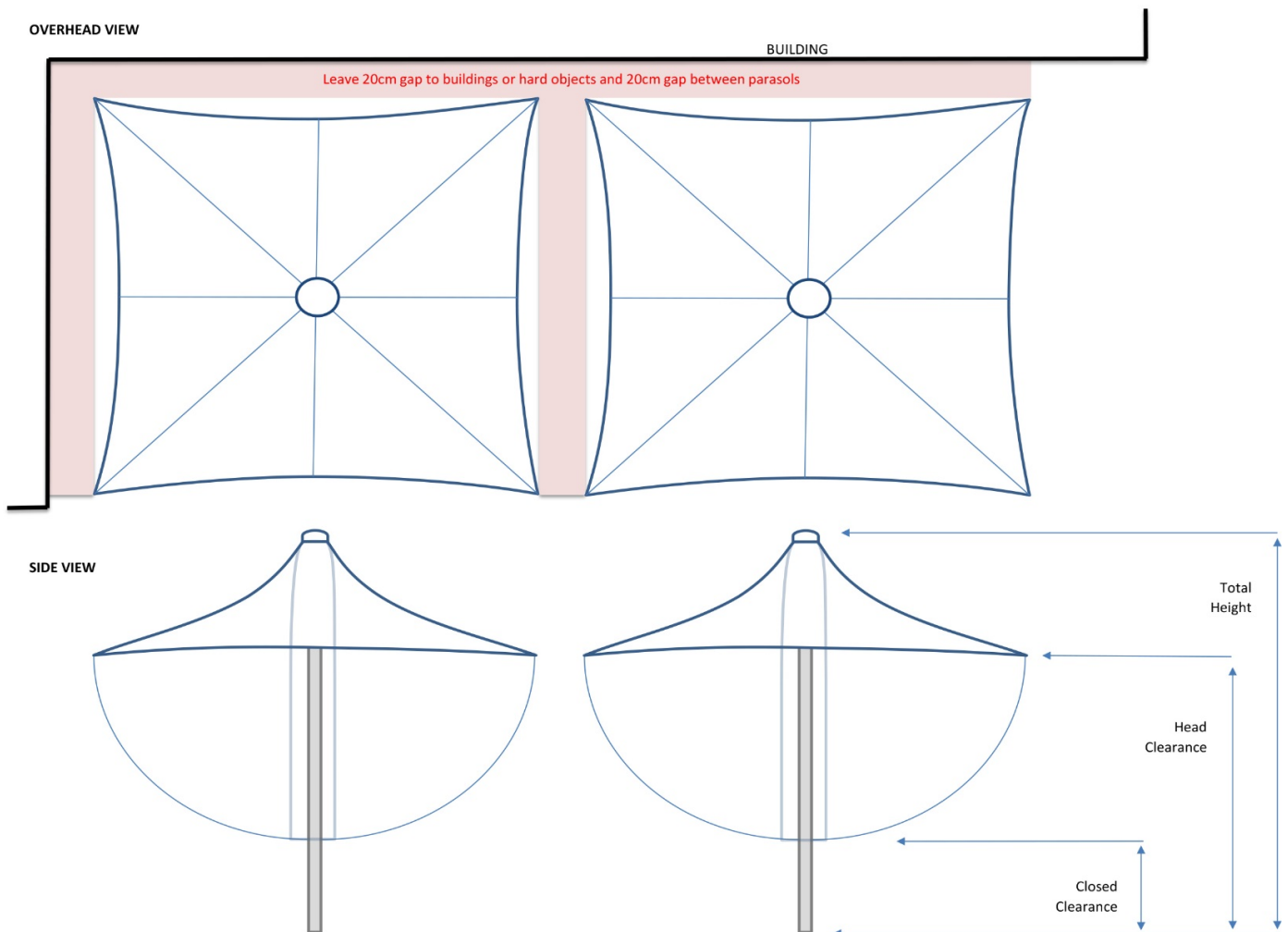

Guttering systems are available to connect Vortex parasols together.

It is not possible to connect Vortex parasols of different sizes together using guttering systems.

## In-ground base

In most cases Vortex parasols will be installed with a standard in-ground base. We would suggest that these are delivered to site before the parasol to enable the required ground works to take place, before the parasol arrives.

An extended in-ground base is available for installation using an auger. This can reduce the volume of concrete used for the installation.

If possible, please ask for the parasol to be delivered to site once the ground works are complete and the concrete has cured.

## Electrical planning

Vortex parasols can be fitted with lights, heaters, screens, speakers and other electrical components.

Should you be planning to fit any electrical appliances the following should be noted,

Electrical power will need to be fed to the parasol, through the in-ground base and up the central core of the parasol.

Electrical cabling placed in the ground should be correctly specified and protected. Please consult an electrician to ensure that the required standards are adhered to.

It may be a good option to lay a conduit to take electrical cable; this would allow cables to be fitted later if required.

If you intend to fit heaters to Vortex parasols you will need to allow a 240v single phase 32A supply per parasol.

If you wish to fit speakers or TV screens, the supply cables need to be shielded from the electrical cables.

Suggested circuit diagrams are provided, please see page 35

## Electrical supply and conduit through in-ground base

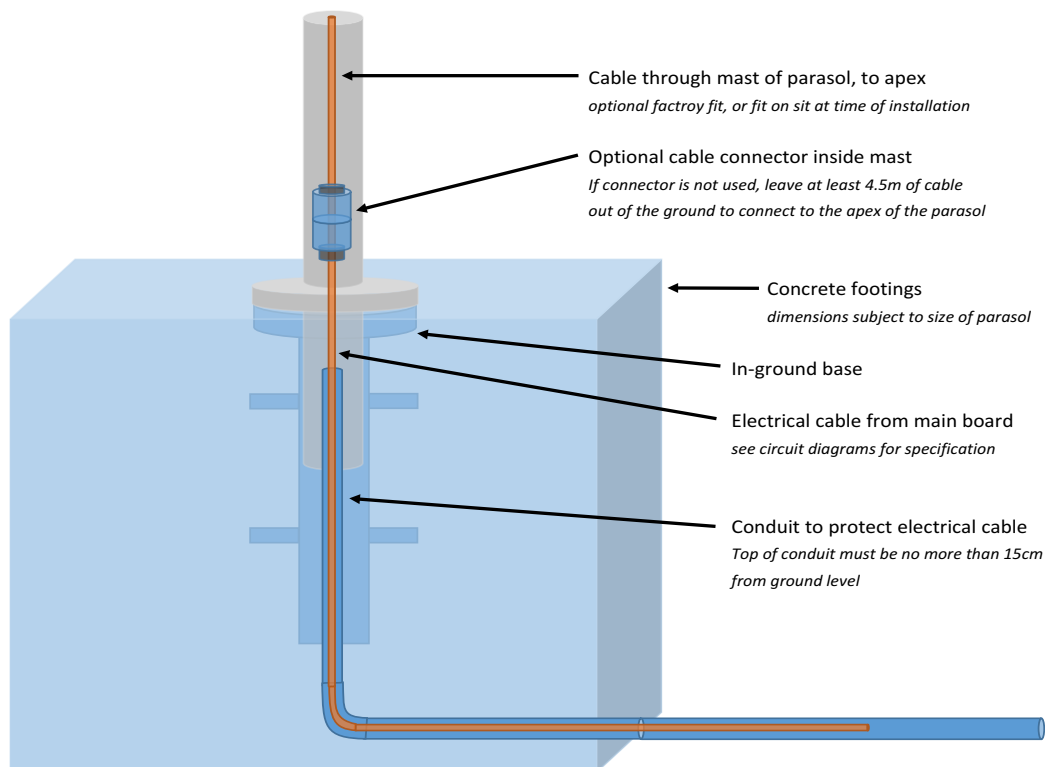

# Base installation

## In-ground base installation

Once the exact position of the in-ground base is decided upon, it can be installed as follows:

To achieve the required wind rating, Vortex parasols require substantial concrete footings to ensure stability. Holes need to be dug to accommodate at least the following footing dimensions.

Should there be any doubt about the suitability and stability of the surrounding soil, the sizes of the footings may need to be increased. Professional help and advice should be sought if required.

## Foundations

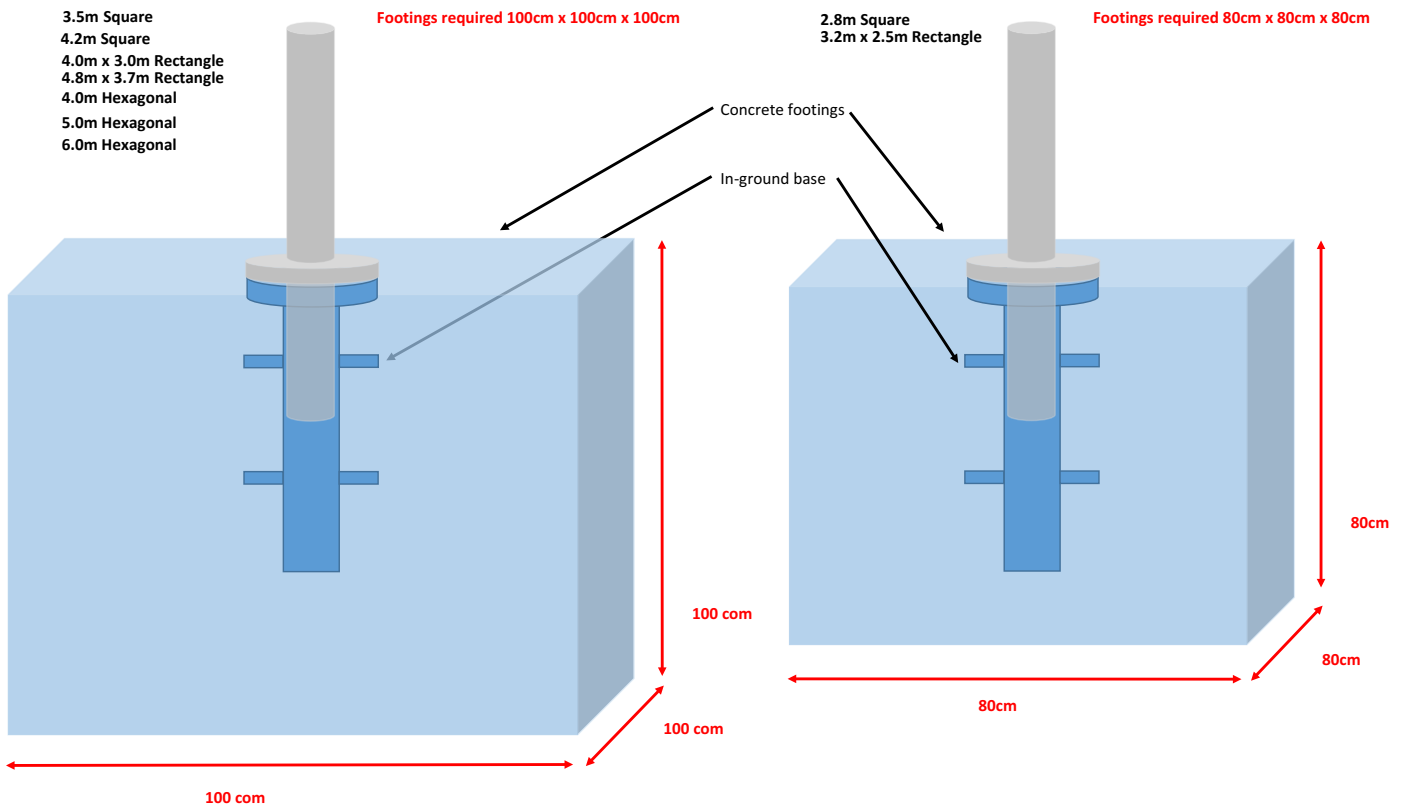

Note: All sizes of Vortex parasols have the same in-ground base tube.

If either electric, speaker or TV cables are to be run to the parasol, conduit should be run from the source through the ground, into the footings and up through the bottom of the in-ground base.

Do not modify the in-ground base to allow cables to be fed through the side of the tube.

## Extended in-ground base installation

The extended in-ground base is 1.5m long and should only be used in suitable soil and ground conditions. It allows use of an auger to drill a deep hole, set the in-ground base into the hole and fill with either resin or concrete.

You may need to seek advice from a structural engineer to see if a particular site is suitable for the extended in-ground base.

## Setting into concrete

One option for setting bases into concrete is outlined below. Other suitable methods exist. For further details or assistance please contact your supplier.

Sections of Vortex main mast are available for installers to assist with installation, if required.

Use a straight timber plank at least as wide as the top of the in-ground base (+/- 200mm) and longer than the width of the concrete footings. Place the in-ground base, upside down, in the centre of the plank. Mark the position of three, alternate holes in the base on the plank and remove the in-ground base.

Drill three, M12 holes through the marked positions of the plank. Place the base back onto the plank and bolt the in-ground base to the plank, from the top of the in-ground base.

Place the plank, with the in-ground base attached to the underside of the plank, into the hole as per the diagram.

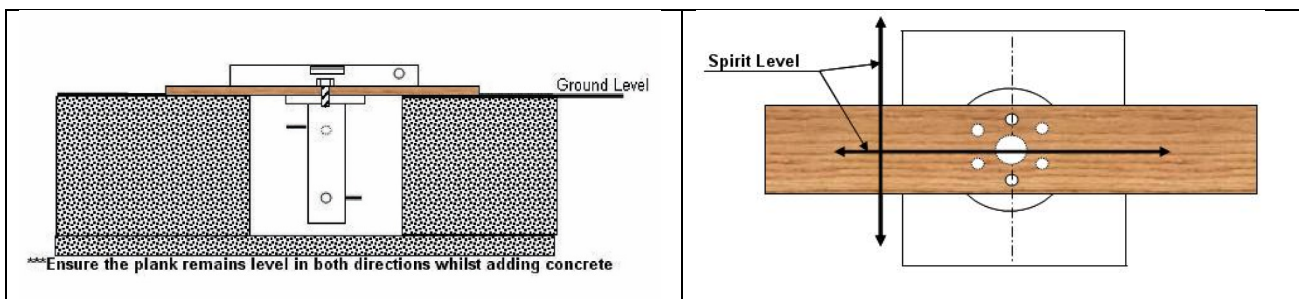

ANY ELECTRICAL, AUDIO OR VIDEO CABLE AND POWER SUPPLY TO THE PARASOL SHOULD HAVE BEEN FITTED BEFORE MOVING ON TO NEXT STAGE OF INSTALLATION.

Using a spirit level on top of the plank, ensure that the plank is level IN BOTH DIRECTIONS.

Fill the hole, from both sides of the plank, with concrete, continuously checking that the plank remains level in both directions.

DO NOT ALLOW THE CONCRETE TO FILL THE IN-GROUND BASE.

## Curing of concrete

Concrete should be left to fully cure prior to erection of the parasols. This will be subject to prevailing weather conditions and in damp, cold or humid environments it can be necessary to allow the concrete to cure for longer periods of time. Local advice may need to be sought, to ensure correct curing times.

Once the concrete has set fully, remove the plank of wood from the parasol and check the level of the in-ground base.

## Deck plates

If using a deck plate, it should be bolted to a suitable solid surface. If it is to be bolted to decking it will be necessary to reinforce the structure below the surface boards. The surface that the plate is being bolted to will determine the size and type of bolts required. You may need to seek professional advice to achieve the correct additional strength in the decking.

Please make a note of the positioning guide on the previous page when installing parasols on a deck plate.



The deck plates can accommodate electrical cables. The cable that provides power to the parasol should be fed through the cable entry and protected with a suitable grommet.

It is often easiest to place the parasol into the deck plate, prior to bolting it down. This is done by standing the deck plate on the side and inserting the base of the parasol into the tube on the deck plate. At this stage the bolts should be fitted, but not fully tightened. The parasol can then be raised to vertical. Check the position of the deck plate and adjust if necessary by sliding the deck plate. Note: care is required to ensure the parasol does not fall over. Once the deck plate is in the correct position it should be bolted down, before the parasol is opened. Do not open the parasol before bolting the deck plate down.

## Free-standing bases

There are a number of situations where in-ground bases or deck plates cannot be used, usually where the surface cannot be drilled or where there are particular issues relating to planning permission.

The installation procedure for the free-standing base is similar to the above deck plate installation. However having positioned the base in the correct location, concrete slabs need to be added in layers, making up the recommended weight of base; 950Kg for the 4.2m square, 850kg for the 3mx4m Rectangular or 750Kg for the 2.8m Square

To cover the slabs an optional stainless steel surround and cushion is available.



**PLEASE NOTE: FREE-STANDING BASES WILL NOT PROVIDE THE SAME STABILITY IN WINDY CONDITIONS. IF IN DOUBT, CLOSE THE PARASOL.**

**If you require wind loading numbers for free-standing bases you will need to consult a structural engineer.**

# Parasol installation

## STEP 1

1 : Take note of opening instructions on the tube

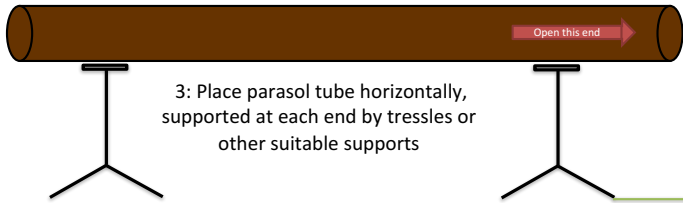

2 : Work close to the position where the parasol will be installed



3 : Place parasol tube horizontally, supported at each end by tressles or other suitable supports

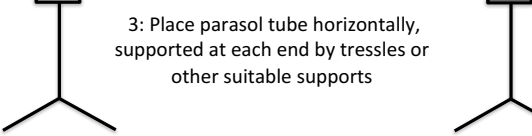

CAUTION : The Tube and contents are heavy please use correct handling procedures



## STEP 2

1 : Remove screws from end of the tube x3



2 : Remove disc from end of tube

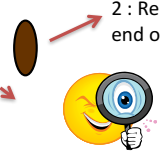

3 : Check for more screws inside the end of the tube, as they will cause damage to the canvas

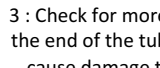

## STEP 3

1 : Remove bag of bolts from end of pole



2 : Carefully slide parasol out of tube, pole end first

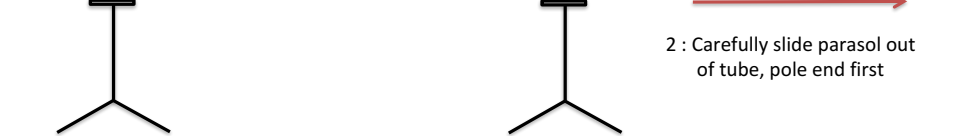

## STEP 4

1 : Lay parasol horizontally on the tressles



2 : Discard tube and recycle!



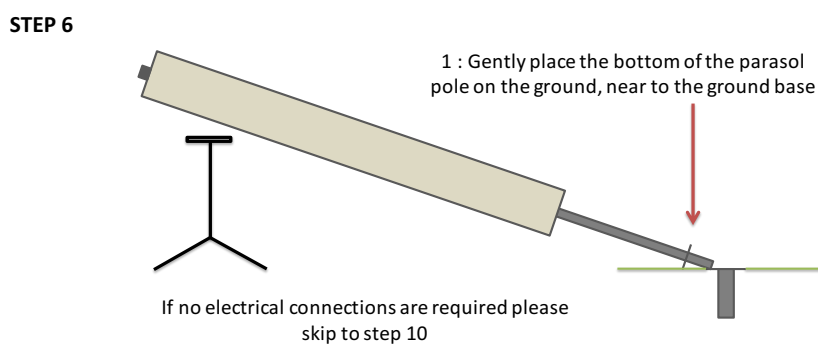
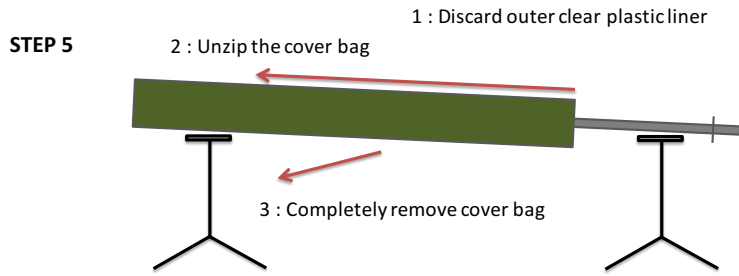

CAUTION : The parasol is heavy please use correct handling

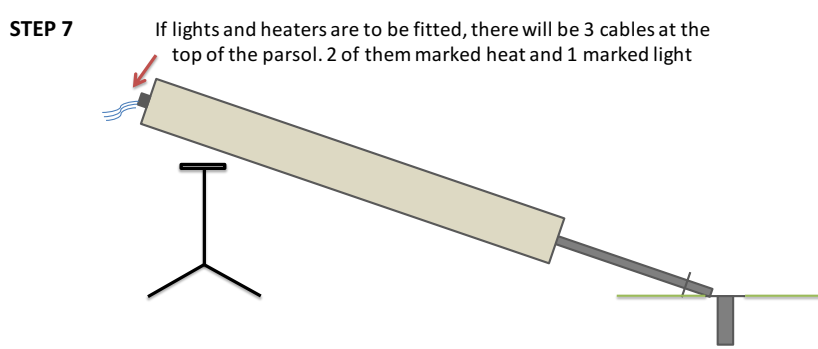

**STEP 8**

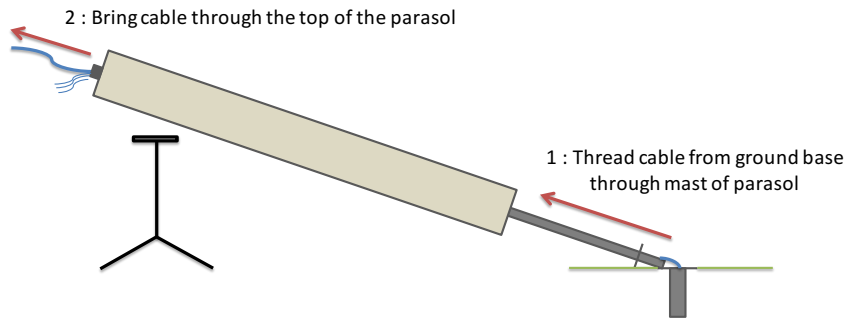

**STEP 9**

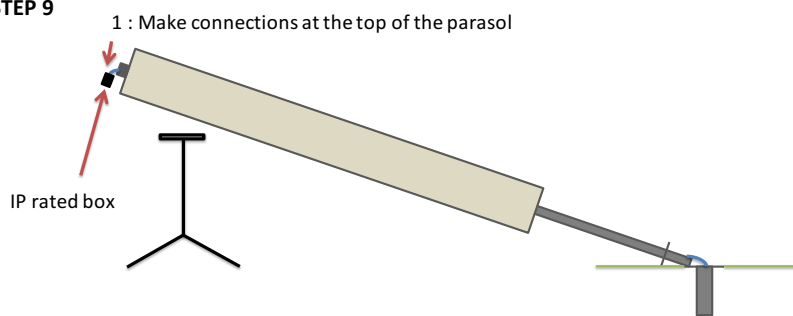

**CAUTION :**  
Connections should be made by a qualified electrician

**STEP 10**

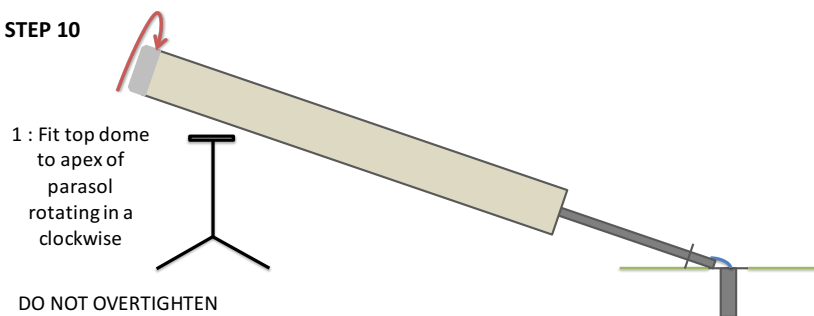

**STEP 11**

1 : Slowly raise the parasol to a vertical position

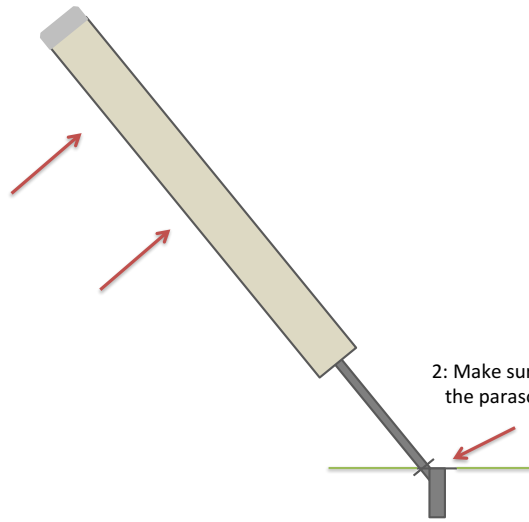

CAUTION : The parasol is heavy and this stage will require at least 3 people

**STEP 12**

1 : Fit all 6 bolts at ground level to secure the parasol in the base

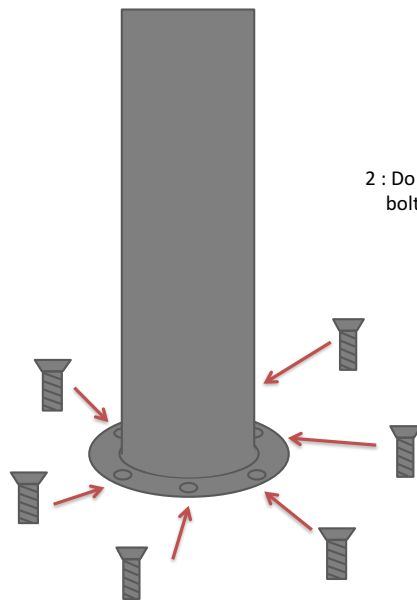

2 : Do not fully tighten bolts at this stage

## Operation

### Opening the parasol

#### STEP 1

1 : Remove the strap from round the parasol

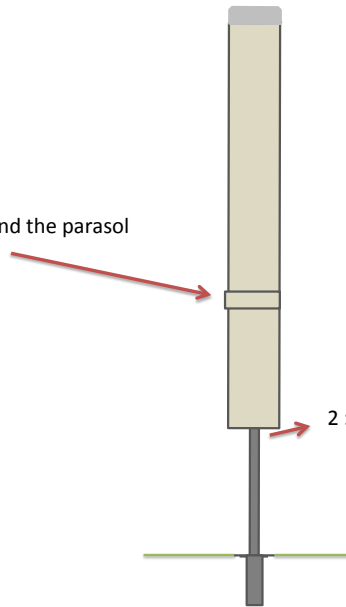

2 : Loosen the fabric around the parasol

#### STEP 2

1 : Locate ropes (2) and pull downwards to open the parasol

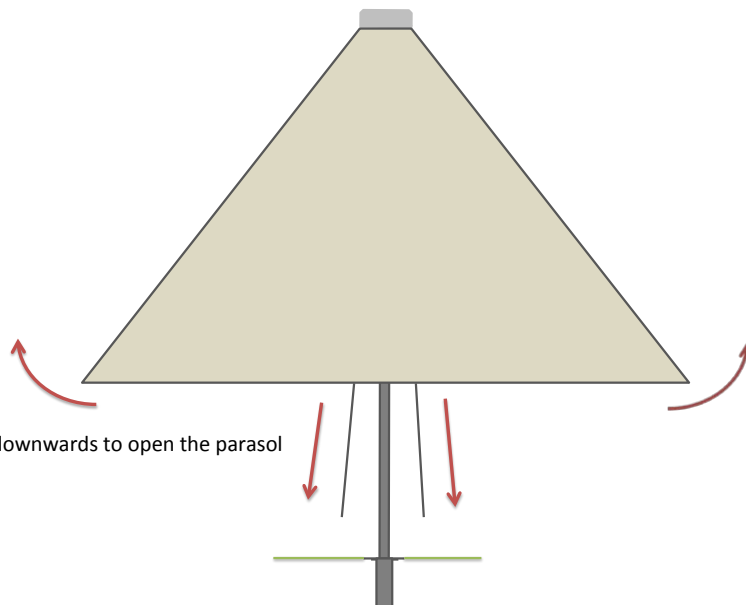

**STEP 3**

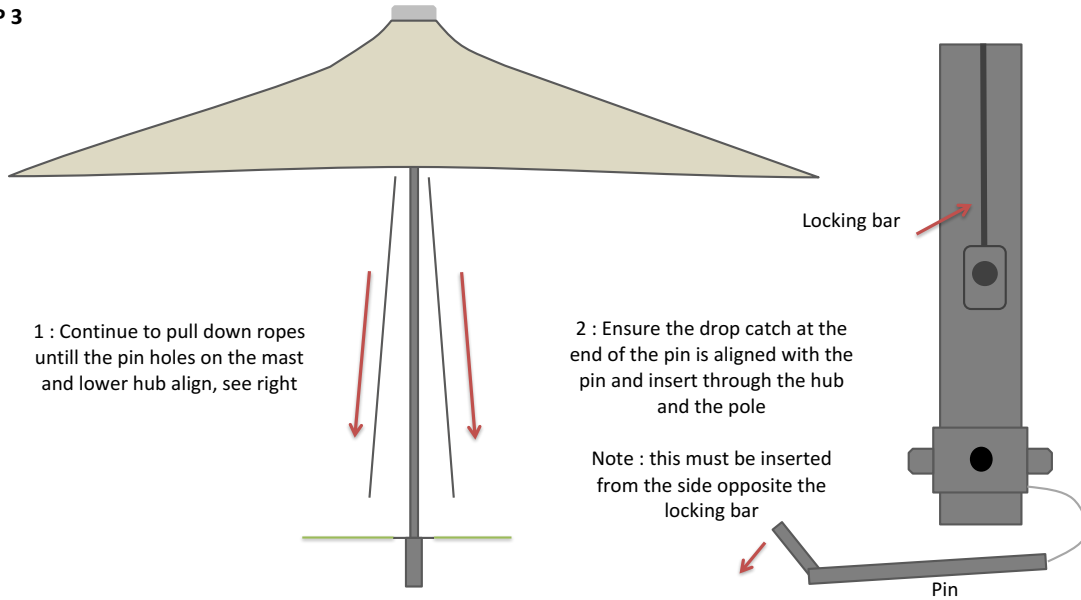

**STEP 4**

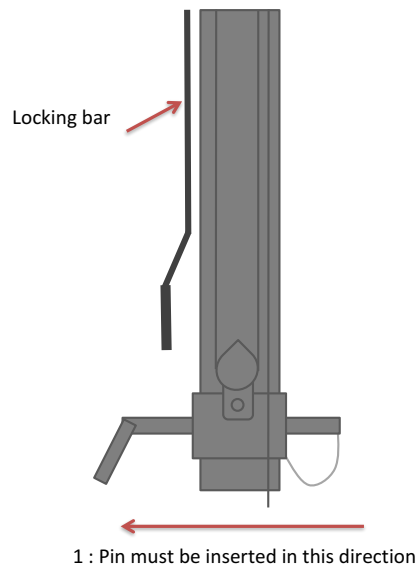

**STEP 5**

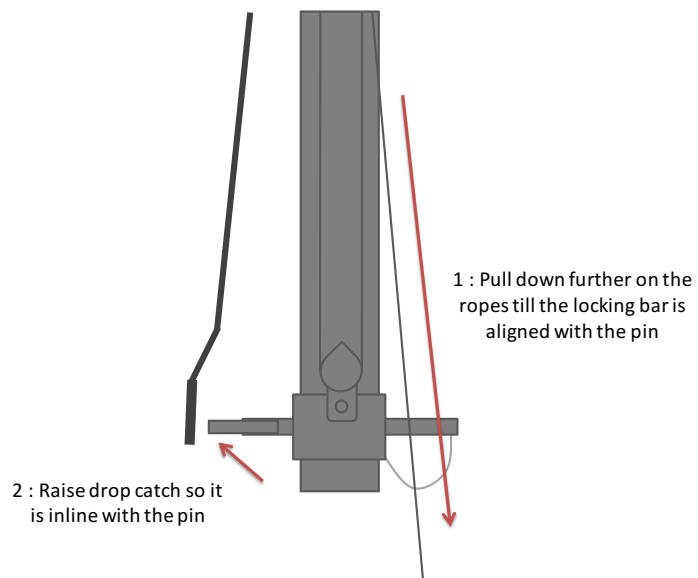

**STEP 6**

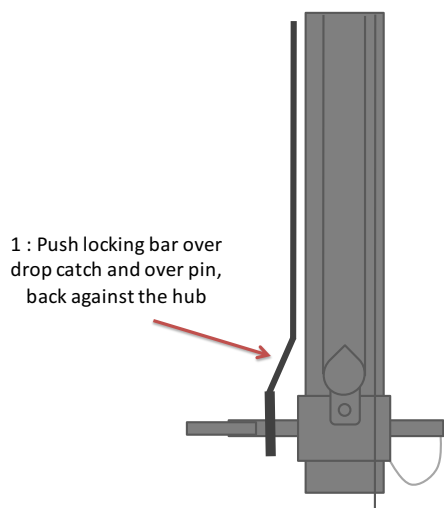

**STEP 7**

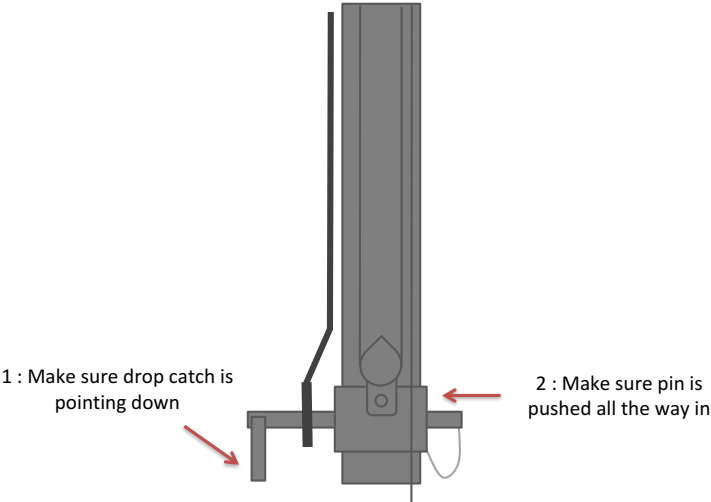

**STEP 8**

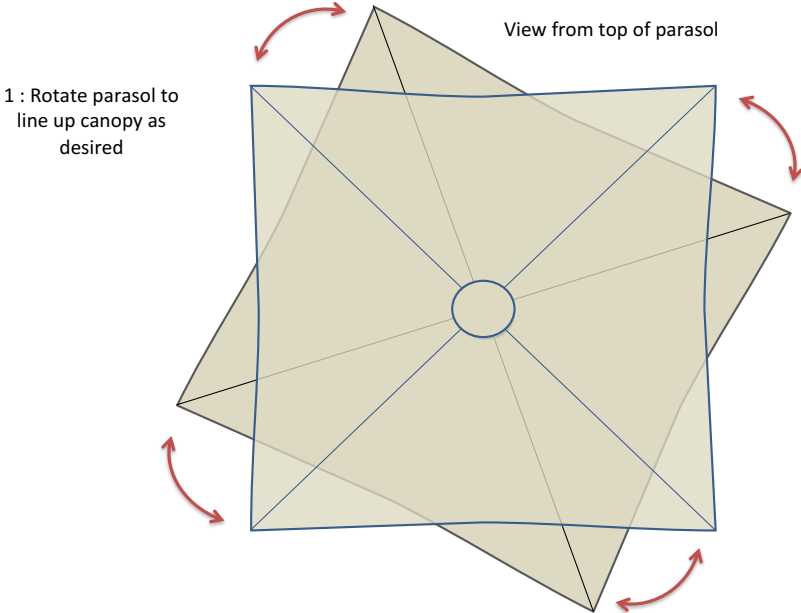

**STEP 9**

1 : Tighten bolts at ground level x6

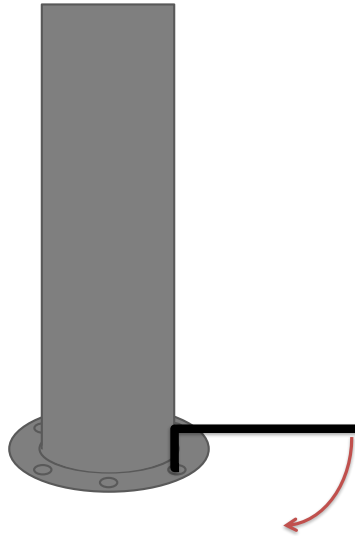

2 : Check parasol is straight and bolts are tight before fitting any electrical items

**STEP 10**

Pulleys can now be removed if desired

1 : Undo pulley retaining bolts and remove pulley from both hubs

2 : replace pulley retaining bolts in the hubs

3 : Padlock can be fitted if required

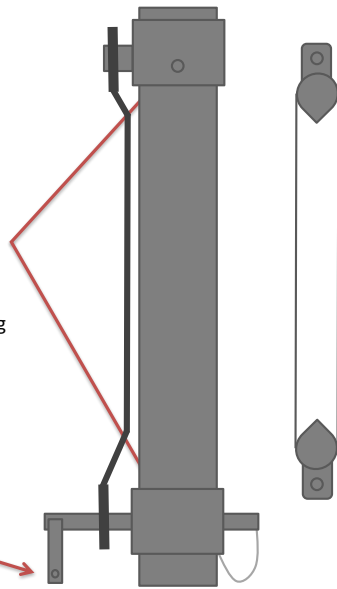

CAUTION : Store the pulleys safely as you will need them to close the parasol

# Closing the parasol

## STEP 1

Pulleys should be refitted if they have been removed

1 : Refit pulleys to both hubs

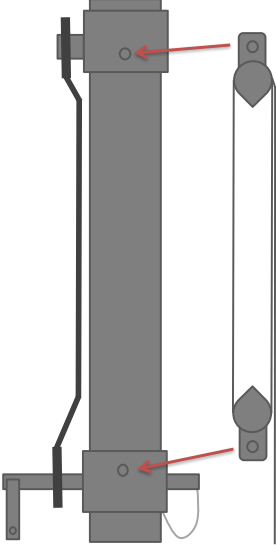

CAUTION : Extreme care is needed if parasols are being closed in windy conditions

## STEP 2

1 : Take up any slack on ropes and hold to avoid parasol closing

2 : Align drop catch with pin

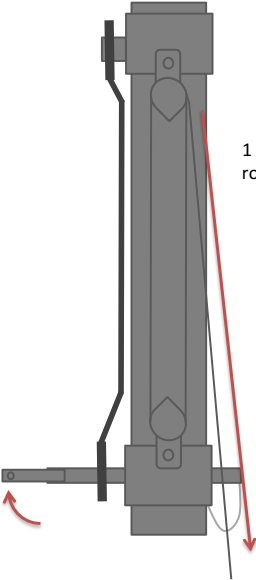

**STEP 3**

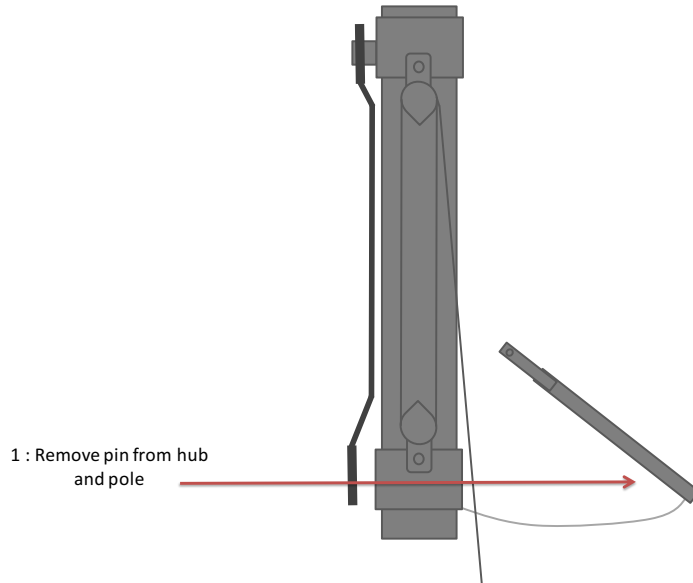

**STEP 4**

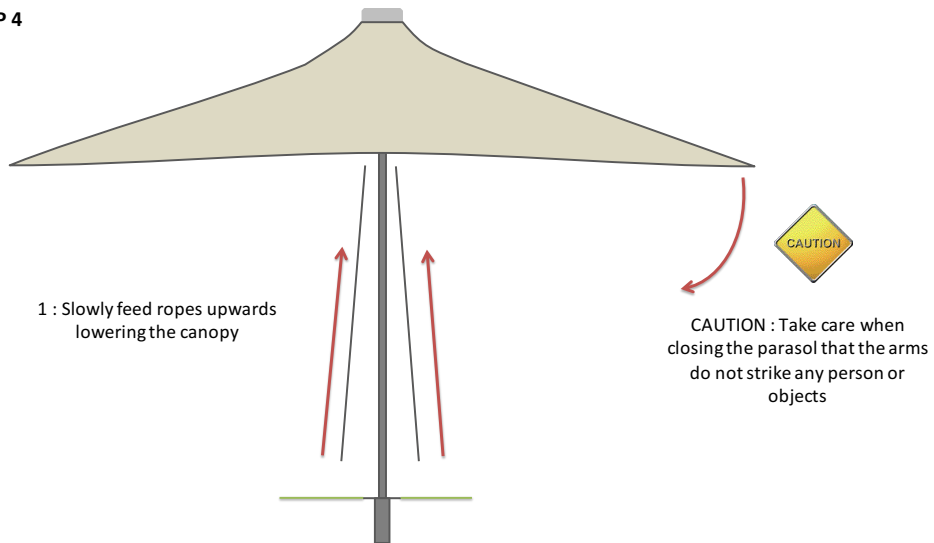

**STEP 5**

Avoid the canvas getting caught between the struts as the parasol closes

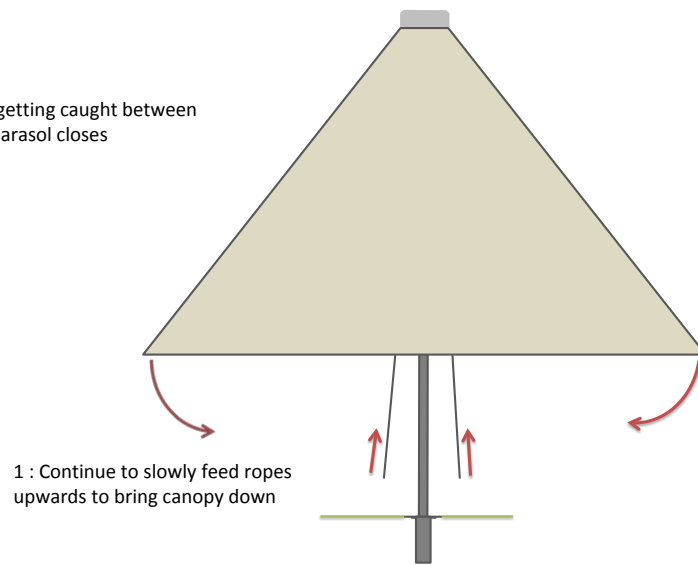

**STEP 6**

1 : Wrap the fabric round the outside of the frame

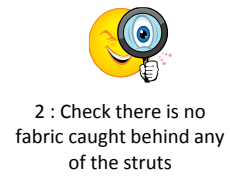
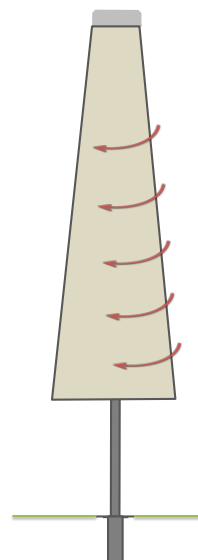

## Short term storage

Ideally Vortex parasols should not be left vertical when closed for extended periods of time, without fitting the optional mast clamp plate, to take the tension out of the canopy.

If left closed without the clamp ring correctly fitted, the canopy can stretch. This is not covered under warranty.

### STEP 1

1 : Replace strap round middle of parasol to secure canvas

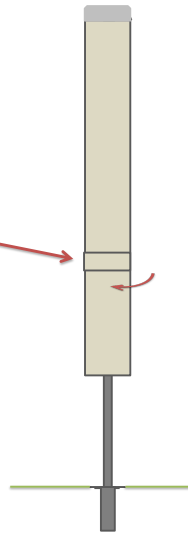

### STEP 2

ENSURE THE PARASOL IS COMPLETELY DRY BEFORE PUTTING THE COVER BAG ON

1 : Replace cover bag over parasol if required

2 : Pull down zip to close cover bag

Tip: Use a long stick, placed inside the bag to help lift the cover bag over the parasol

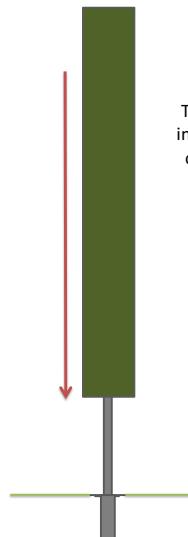

## Long term storage

If your Vortex parasol is to be left closed and remain standing vertical you will need to fit the optional mast clamp ring. This is designed to hold the weight of the arms and hubs up, as opposed to them being supported by the canopy.

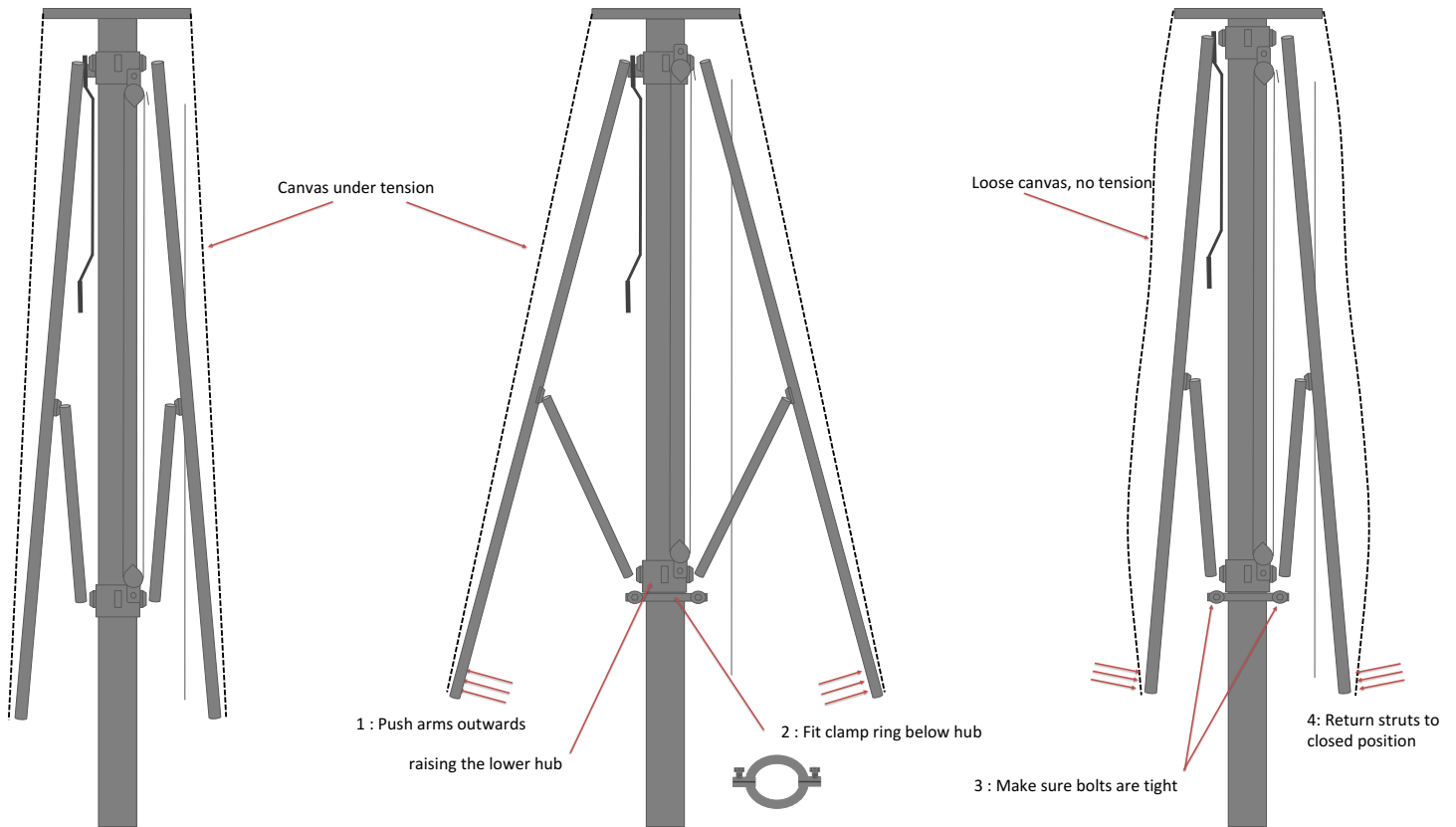

To fit the clamp ring, open the arms of the parasol, so the lower hub lifts by about 50mm. Fit the clamp ring around the mast and do the bolts up tightly. Slowly release the arms back to the closed position. You should find that the tension in the fabric between the end of the arm and the top of the parasol has been released.

Periodically check that the fabric is still loose and that the ring has not slipped down the mast.

If this has happened, it is most likely that the bolts on the clamp ring were not tight enough. Repeat the whole procedure above, making sure that the clamp ring is tight.

## Fitting heaters and lights

Lights and the heater hub should be fitted to the mast, between the two hubs, in the positions shown below.

Heaters should be fitted to the arms and plugged in to the heater hub, as shown.

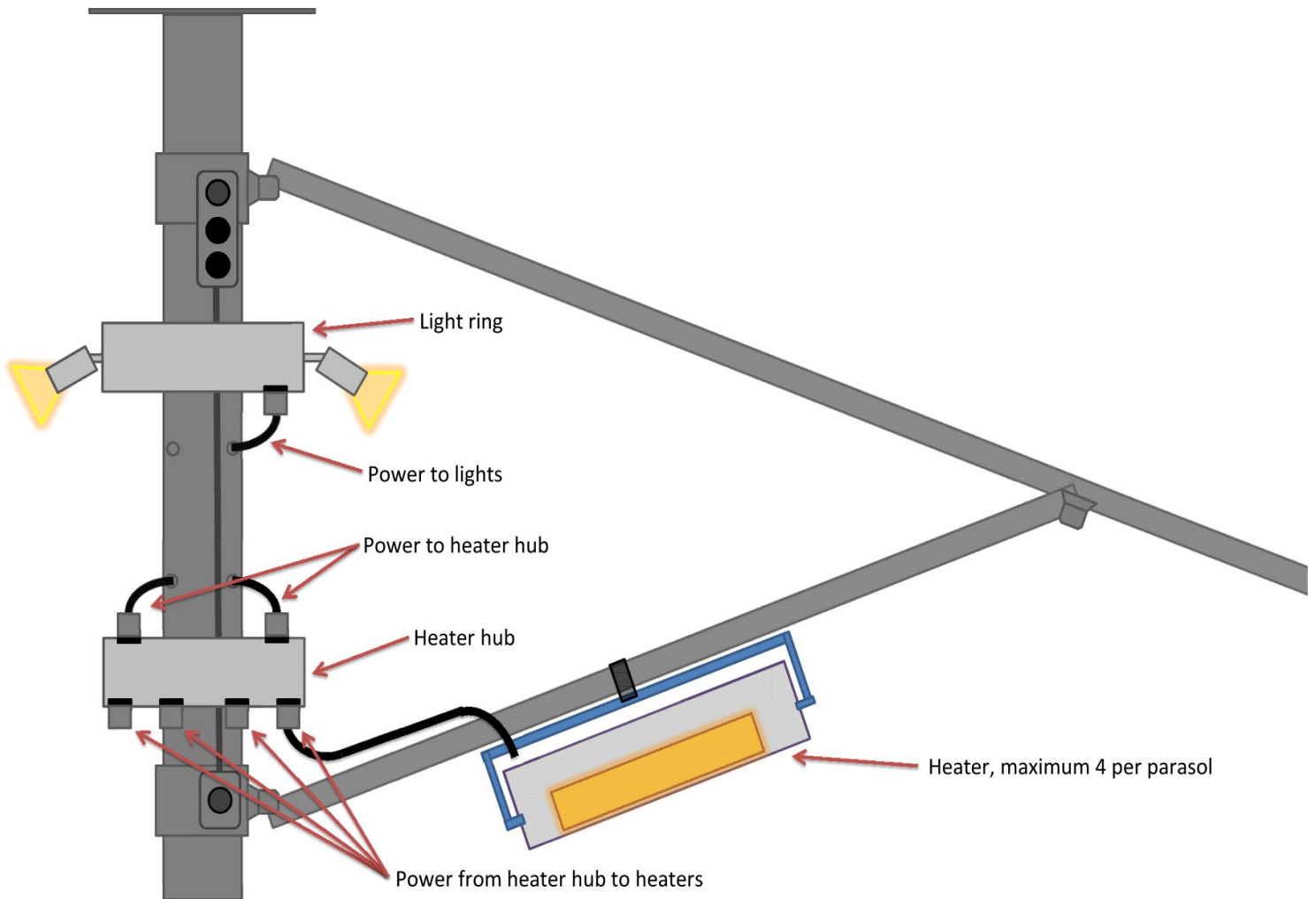

## **Safety**

The following notices should be read carefully. They can also assist with the production of any required risk assessment documentation that might be required.

In cases where severe weather warnings are issued, the umbrella should be closed prior to the onset of such conditions.

### **PLEASE BE AWARE THAT ANY DAMAGE CAUSED BY WIND IN EXCESS OF 100KM/H IS NOT COVERED UNDER WARRANTY.**

Please ensure that all heaters are allowed to cool and removed from the parasol before any attempt is made to close it.

### **HEATERS LEFT INSIDE PARASOLS THAT ARE CLOSED CONSTITUTE A FIRE RISK.**

### **HEATERS MUST BE REMOVED BEFORE CLOSING THE PARASOL.**

Lights can be left inside the parasol when closed, but must be turned off and cool at all times when the parasol is not fully open. If lights are to remain inside the parasol when it is closed, ensure that the struts do not catch the light units when closing the parasol.

## **Bases**

We strongly advise that these high tension parasols are installed using the in-ground bases. Parasols used without bases, bases that are too light, or not correctly fitted, can be a hazard. Please ensure that any base system used is proportionate to the size of the parasol and correctly fitted.

You should regularly check to ensure that the bolts used in any base or ground base are tightened correctly.

Where parasols are used with ground bases, ensure that there is no movement in the ground base and that when the parasol is up it is vertical.

Parasols fitted to free-standing bases should be closed in windy conditions.

## **Moving Parasols**

Ensure that the electrical supply to the parasol is disconnected before moving the parasol.

Be aware that if moving parasols they are large and heavy items. Removing them from bases or ground fittings should be carried out with care to ensure that there is no risk of injury or risk of damage to the parasol.

You should only ever attempt to move parasols when in the closed position. Parasols should be folded down completely; the fabric should be wrapped correctly round the frame, strapped and have a cover bag or transport bag fitted before they are carried.

Always carry parasols when they are in a horizontal position, never try and carry a parasol when it is vertical.

Up to 8 people can be needed to move large parasols safely. You also need to be aware that the weight distribution is not even along the length of the parasol. It is likely that the top of the parasol will be heavier than the bottom. Please ensure that you understand the weight distribution before undertaking a lift.

## Parasols with electrics

If parasols with integrated heating and lighting are fitted please ensure that installation instructions have been followed correctly. IMPORTANT - heaters and lights should be individually protected by an RCD. They should be switched by suitable PIR sensors or by individual switches.

## Heaters

Please ensure that the power to the parasols is switched off before connecting or disconnecting any heaters.

Heaters should always be removed from parasols before closing the canopy. Before heaters are removed they should be allowed to fully cool before any attempt to remove them. Please check carefully, after 20 minutes, starting at the back of the heater, that the whole unit is fully cooled before removing it. It is not necessarily possible to tell if a heater is hot from visual inspection.

Lights should be removed when the Vortex is closed, however correctly positioned it is possible to leave them in the parasol when it is closed. Ensure that the lights are turned off and cool before the parasol is closed.

Heaters should be mounted on the parasols at a height that is out of reach, ideally at a height of 2.4m from the ground. As such great care needs to be taken when removing heaters from parasols. You will need steps to reach the heaters and all sensible, usual precautions should be adhered to when using steps. These steps will need to be at a height that enables easy reaching of the heater brackets. Steps should be moved round the parasol to remove each heater, rather than trying to reach around the side of the pole to remove heaters from the opposite side.

The effort required to remove the heaters is worthwhile. Following the guidelines above reduces the risk of damage to the canopy that can be caused by hot heaters and also damage to the heaters if they are dropped or knocked.

## Product warranty

### Frame warranty

Vortex High Tension umbrellas are guaranteed, from original date of purchase by the initial buyer, for a period of up to 5 years\* against defects in metal fixtures resulting from faulty workmanship and faulty materials. Although we strive to provide the highest quality, we accept no responsibility for print degradation.

The manufacturer will not be liable for any extra costs incurred by the buyer as a result of defects found in the product or as a result of faulty product, over and above those covered in the guarantee contained in the paragraph above.

\* 5 year warranty requires product registration with the manufacturer.

### Canopy warranty

Fabric warranty is provided by the manufacturer of the material used in the canopy. This can vary with the choice of material. Please refer to the table for a summary, or the following section for detailed information on the fabric warranty for the standard fabrics.

Please note tensile fabrics will only be covered under warranty when tensioned, in this case when the parasol is fully open.

### Modification

Please note that due to the nature of the parasol, ANY modification of the parasol will invalidate the warranty. Not limited to, but including:

- **Do not shorten the pole**
- **Do not shorten the bottom of the pole below the flange at the bottom of the pole.**
- **Do not shorten the in-ground base**
- **Do not drill additional holes in the pole**
- **Do not widen any of the holes provided in the pole for power cables.**

Modification made by the factory, prior to delivery will be covered by standard warranty terms, except for wind loading guarantees. No wind loading guarantee is provided for any modified product, whether factory modified or not.

### Heaters and lights warranty

All heating and lighting systems warranties are supplied by the manufacturer of the relevant components.

### Warranty summary tables

Frame		Canopy		
No registration	With registration	602	502 Satin	6002 STAM
2 years	5 years	0	10 years	5 years

Heaters		Other options	
Solamagic	2 years, 10,000 hours	Solamagic lights	2 years
Victory Lighting	5,000 hours	Stainless Heater brackets	2 years
Tansun	2 years 7,000 hours		

*Note: any hours specified for heaters is purely an expected lifespan of the bulb under normal conditions.*

For more specific information on electrical warranties, please refer to the documentation supplied with the component.

## Ferrari 502 Satin - 10-year limited warranty



Applications: awnings and fixed shading systems

Manufactured according to the Serge Ferrari Technology and benefiting from the ISO 9001 Quality Assurance system, composite materials are guaranteed for 10 years for the mentioned applications.

### Warranty

Are guaranteed against any abnormal degradation of their main characteristics as part of normal use: breaking strength at least 30% of its original value, uniform colour change over time, for the same orientation and exposure, fire resistance as specified in the original technical document, impermeability.

### Warranty application conditions

The warranty takes effect on the day of delivery of the membranes to the customer.

In the event of proven liability, the warrantor declares its readiness to reimburse all or part of the costs of repair or replacement, subject to the conditions set forth in the table below. The percentage contribution of the warrantor shall take into account the warranty limits stated below, the installation conditions for the product and its exposure time.

The right to warranty only applies if the imperfections are reported by registered letter with acknowledgement of receipt to Serge Ferrari within a maximum time period of 30 calendar days of their occurrence; the invoice of the goods must also have been fully paid. A product purchase receipt shall be required in support of any claim. The sum reimbursed by the warrantor shall not exceed the initial purchase price paid by the first acquirer.

The costs of repair or replacement not covered by the warrantor following reimbursement shall remain payable by the third party.

This warranty does not therefore cover the labour costs or those resulting from the disassembling, reassembling and transportation operations. Furthermore, no monetary compensation is provided for under the terms of this warranty.

The sum covered by the warrantor shall be proportional to the number of years between the start of exposure and the appearance of the defect:

Appearance of the defect	10-year warranty (Maximum percentage coverage by warrantor)
1 <sup>st</sup> year	100%
2 <sup>nd</sup> year	80%
3 <sup>rd</sup> year	65%
4 <sup>th</sup> year	50%
5 <sup>th</sup> year	40%
6 <sup>th</sup> year	30%
7 <sup>th</sup> year	25%
8 <sup>th</sup> year	20%
9 <sup>th</sup> year	15%
10 <sup>th</sup> year	10%



## **Exclusions**

Liability under the warranty is excluded, if damage results from:

- Non-compliance with installation recommendations and directions issued by the warrantor.
- Lack of fabric tension (for example slack, skewness) and installation on a retractable system. Précontraint 502 Satin material must remain faultlessly tensioned.
- Tear or repair during installation.
- Improper usage, negligence, product alterations, accidental damage of external covering, premature wear, rubbing, scratching, perforation exceeding normal wear.
- Exposure to chemicals, damage caused by machinery, devices or persons, excessive pressure, exceptional meteorological conditions, falling objects, explosions, fire, flooding, rioting, civil unrest, war, resorting to violence, faulty installation or improper implementation, radiation, aggressive vapour or dust in suspension.
- Damage during storage or installation by installer or final customer, exposure to heavy air pollution, cleaning with over- aggressive or unsuitable products.
- Application to or within structures non-compliant with construction standards applicable at the installation location, repairs or alterations causing loss of product performance performed by a person unauthorized by the warrantor.
- Any operation subsequent to material delivery, such as printing (notwithstanding the method used), welding or thermo-gluing of additional parts or fabrics.

On declaration of the defect referred to, the warrantor reserves the right to inspect and test the implicated product to determine the measures to be taken to remedy the defect. The warrantor, moreover, refuses any liability under the warranty, if the third party breaches the right of the representatives of the warrantor to examine the defect referred to.

## **Limitations**

This warranty is limited and applies exclusively to the specified product and intended usage. It replaces all previous promises or warranties, either explicit or tacit, written or oral.

The warrantor refuses any liability regarding installation of mediocre quality or application not conforming with product specific characteristics.

With regard to services under warranty, any possible claims concerning products and the liability of the warrantor shall be exclusively governed by these terms and conditions of limited warranty. The third party accepts the present warranty clauses and certifies that no warranty or promise of warranty, other than the present clauses, has been concluded or foreseen with regard to the products or accessories supplied by the warrantor.

## **Limitations of liability**

The warrantor cannot be held liable for losses of income, commercial or operational losses, financial charges or any other specific, consequential, circumstantial or mediate loss of any kind, possessing a causal link to, or related to, the products covered by this warranty, their implementation or usage, or the impossibility of using the said products or their late delivery. The warrantor shall decide at its convenience on the measures to be taken, if the liability of the warrantor is recognized, within the limits of the aforementioned provisions with regard to repair, defect elimination or product replacement. Costs of replacement shall not be reimbursed.

## **Final conditions**

The competent jurisdiction governing any dispute resulting from the terms and conditions of this warranty shall be that of the registered office of the warrantor (Bourgoin-Jallieu, 38 France). This warranty agreement is governed by French law.

All questions or actions in warranty relating to the limited warranty defined above shall be addressed to:

Serge Ferraris  
B.P. 54  
38352 La Tour du Pin Cedex France

## Ferrari 6002 STAM - 5-year limited warranty

Applications: awnings and fixed shading systems

Manufactured according to the Serge Ferrari Technology and benefiting from the ISO 9001 Quality Assurance system, composite materials are guaranteed for 5 years for the mentioned applications

### Warranty

Are guaranteed against any abnormal degradation of their main characteristics as part of normal use:

- breaking strength at least 70% of its original value,
- uniform colour change over time, for the same orientation and exposure,
- fire resistance as specified in the original technical document,
- impermeability.

### Exclusions

The warranty is excluded if the fault comes from:

- Defects attributable to transportation, storage and handling conditions,
- Errors of design, making-up, assembling and use in inappropriate conditions, in particular under the action of strong winds,
- The consequences of chemical or abrasive attacks
- Unsuitable cleanings
- Atmospheric pollutions or accidental projections

### Warranty application conditions

The warranty takes effect on the day of delivery of the flexible composite materials to the customer.

The right to warranty only applies if the imperfections are reported by registered letter with acknowledgement of receipt to Serge Ferrari within a maximum time period of 30 calendar days of their occurrence; the invoice of the goods must also have been fully paid.

This warranty does not therefore cover the labour costs or those resulting from the disassembling, reassembling and transportation operations. Furthermore, no compensation is provided for under the terms of this warranty.

Under the guarantees of paragraph 1, and subject to the exclusions in paragraph 2, we will supply the necessary yardage to replace the project following a depreciation coefficient as described below.

Appearance of the defect	10-year warranty (Maximum percentage coverage by warrantor)
1 <sup>st</sup> year	100%
2 <sup>nd</sup> year	80%
3 <sup>rd</sup> year	60%
4 <sup>th</sup> year	40%
5 <sup>th</sup> year	20%

# Canopy maintenance and cleaning

## General information

The purpose of these instructions is to outline maintenance procedures for the PRECONTRAI<sup>®</sup> M2 membranes, standard inspections and cleaning procedures that are not permitted.

The Precontraint<sup>®</sup> M2 membranes, designed using the PRECONTRAI<sup>®</sup> technology, are subjected to detailed inspections, in adherence with the ISO9002 quality assurance system. Like all high-performance materials, the PRECONTRAI<sup>®</sup> M2 membranes retain their properties if they are maintained in the fashion described in these instructions.

## Maintenance Inspections conditions for the Precontraint<sup>®</sup> M2 membranes

The composite structure of the PRECONTRAI<sup>®</sup> M2 membranes (polyester, PVC, surface treatment) makes them extra resistant to climatic and atmospheric damage: wind, sun, rain, micro-organisms, dust and miscellaneous pollution.

Maintenance involves no more than periodical or specific inspections and periodical or specific cleaning.

The frequency and the type of these inspections depends essentially on:

- the working position of the textile: in a vertical position, deposits will be less damaging than in a horizontal position.
- the exposure of the textile to climatic precipitation (rain, wind, hail, snow etc.) and organic deposits (leaves, pollen, dust etc.)
- the type and the intensity of the deposits.

### Periodical inspections

The periodical inspections consist of visual checks of the membrane with regard to the following problems:

- tears on the edges and inside the panel,
- fur on the welded sections,
- thick deposits on the surface (dead leaves, insects, ash etc.).

When a problem is discovered, be sure to inform the manufacturer/installer, who will decide what action should be taken

### Specific inspections

The specific inspections are similar to the periodical inspections, the difference being that they are used to assess damage caused by an exceptional accident or incident.

Such damage can be caused by the following events:

- heavy storm or high winds
- snow or hail generating weight loads
- accidental impacts of large, sharp or corrosive foreign bodies.

## Canopy cleaning procedures

### Periodical cleaning Specific cleaning operations

The PRECONTRAI NT® M2 membranes are particularly resistant to polluting agents for two principal reasons:

- the smooth surface has very few micro-cavities that could hold deposits on a sustainable basis.
- in the case of the FLUOTOP T2 membranes, the PVDF surface treatment forms a protective non-stick coating across the entire surface area of the textile.

However, to prevent a sedimentation of the polluting agents, the textile should be cleaned regularly.

The cleaning procedure is as follows:

Use a soft brush (nylon) or a sponge. Wash the textile with a FORMULA S detergent solution, respecting the following dosages:

Dirt	Concentration	Water temp.
Minor	5%	20°C
Medium	10%	20°C
Major	10%	50°C

Rinse with fresh, clean water

Certain deposits can be difficult to remove using the cleaning process described above. Such deposits could be formed by the following substances:

- mineral deposits.
- fatty bodies, tar, limestone.
- plant life deposits: leaves, pollen, resin.
- animal deposits: bird droppings, crushed insects.

These deposits can be too much for standard cleaning procedures. They may require the use of other products, which can be damaging to the membrane.

Before proceeding with the use of any such product, it is important to evaluate the necessity of such an action and to call on the services of a professional.

### Procedures and cleaning agents not permitted for the Precontraint® M2 membranes

The resistance of the PRECONTRAI NT® M2 membranes to chemical damage depends on numerous factors such as:

- the state of the chemical agents (solid, liquid or gas),
- temperature,
- concentration,
- length of contact.

In certain cases, a mix of agents can have a damaging impact, whereas the chemical agents may be inoffensive on their own.

In view of this, the following cleaning procedures are not permitted under any circumstances:

- The following inorganic chemical products:
  - o ammonia, nitric acid, sulphuric acid acetic acid, hydrochloric acid, soda, caustic soda, bleach.
- abrasives of any type:
  - o powders, pastes, liquids, abrasive sponges etc.
  - o pressurised steam raising units
  - o non-high-pressure water boilers
- The following organic chemical products
  - o acetone, petrol, benzene, fuel oil, kerosene, perchlorethylene, turpentine, toluol, trichloroethane, oil, THF, ethyl acetate, hydrogen peroxide.

# Frame maintenance and cleaning

## General information

The purpose of these instructions is to outline maintenance procedures for the Vortex stainless steel frames and, standard inspections and cleaning procedures.

The frames are subject to rigorous testing and quality control, prior to assembly and fitting of the canopies and despatch, to make sure that they reach their intended place of installation.

Correctly maintained, the Vortex frames lifespan should far exceed any warranty period.

## Maintenance inspections conditions for Vortex frames

The stainless steel structure of the Vortex frames makes them extra resistant to climatic and atmospheric damage: wind, sun, rain, micro-organisms, dust and miscellaneous pollution.

Maintenance involves no more than periodical or specific inspections and periodical or specific cleaning.

The frequency and the type of these inspections depends essentially on the location in which the parasol is installed.

- Coastal and exposed sites will need more regular checking cleaning
- City centre sites may need more regular cleaning to remove dirt build up, but less maintenance checks.
- Sheltered sites in non-urban areas will need less cleaning and less checking

## Periodical inspections

The periodical inspections consist of visual checks of the frame, looking for any of the following issues

- Bolts coming loose
- Brown deposits on the stainless steel. This indicates contaminants, rather than rust.
- Correct positioning of the pin and the locking bar on the lower hub.
- Stress cracks in any stainless steel components.

When a problem is discovered, be sure to inform the manufacturer/installer, who will decide what action should be taken.

## Specific inspections

The specific inspections are similar to the periodical inspections, the difference being that they are used to assess damage caused by an exceptional accident or incident.

Such damage can be caused by the following events:

- heavy storm or high winds
- snow or hail generating weight loads
- accidental impact.

Parasols showing any sign of damage must be closed immediately.

Bolts that have come loose should be tightened using an appropriate sized Allen key.

Check the pin position against the diagram on page 15 and correct if necessary.

## Frame cleaning procedure

The frame can be cleaned with a damp sponge or cloth, using a mild soap solution, Dry with a soft cloth. A layer of car wax can be applied for additional protection.

If the surface of the stainless steel shows signs of tarnishing (this is normal). Poles and arms can be cleaned with 3M Scotchbrite abrasive pads or similar.

A number of products are available to help clean and maintain the appearance of the framework.

Contact your supplier for availability.

### CLEANING METHODS

Problem	Cleaning Method	Comments
Standard cleaning	Soap and water	Sponge, rinse with clean water and wipe dry
Fingerprints	Soap and warm water or stainless steel cleaner	Rinse with clean water and wipe dry
Oil/grease marks, other stains and light discolouration	Pro-Railing Enviro-Shield	Follow instructions on the box
Heavy discolouration	Stainless cleaning gel	Rinse well with clean water then use Pro-Railing Enviro-Shield
Scratches on satin finish (Mirror finish will need repolishing properly)	<u>Slight scratches</u> Use fine polishing cloth coated with stainless steel cleaner  <u>Deeper scratches</u> Use coarse cloth first then fine cloth with cleaner (as above)	Do not use steel based cleaning products (wire wool) as this will embed in the surface and will cause further surface damage and discolouration
Paint/ graffiti	Use a generic paint stripper dependant on type of paint	Use soft bristle brush and treat afterwards with Pro-Railing Enviro-Shield

Polishing Cloths  
For removal of light scratches on stainless tube and fittings

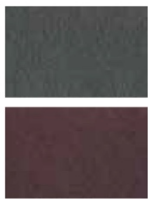

Stainless Steel Cleaner (400ml)  
Degreases & cleans surfaces ready for gluing



Stainless Cleaning gel (2kg)  
Pickling gel helps remove rust, dirt and grime from stainless steel



After Care Tea Staining 3-Part Cleaner kit  
Keeps stainless steel fittings in top condition long after installation



## Spare Parts

Spare parts are readily available. Should there be any need for spares please contact your supplier.

Please see the diagrams on the following pages for identification of any parts required.

# Vortex frame diagram

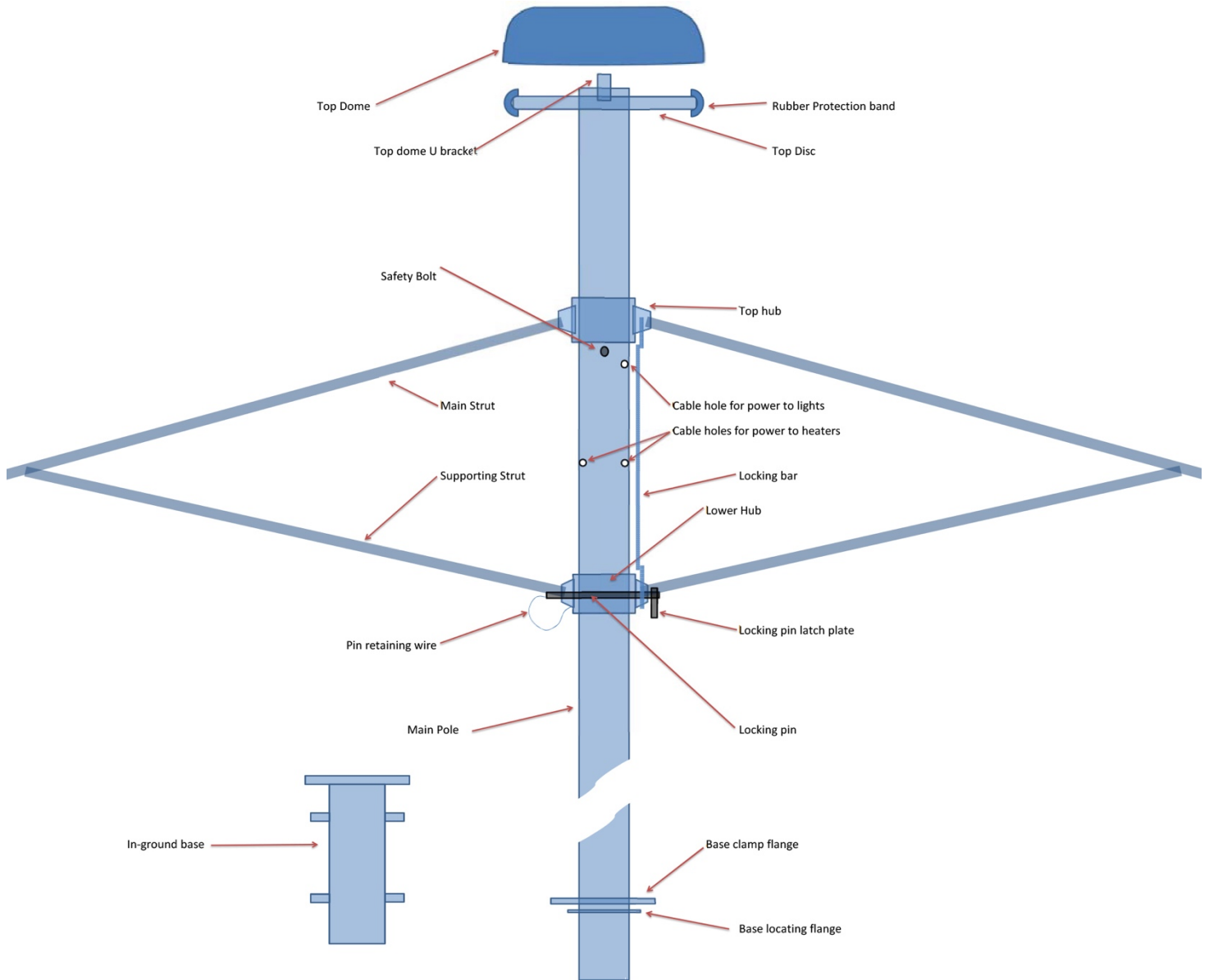

# Vortex electrical layout schematic

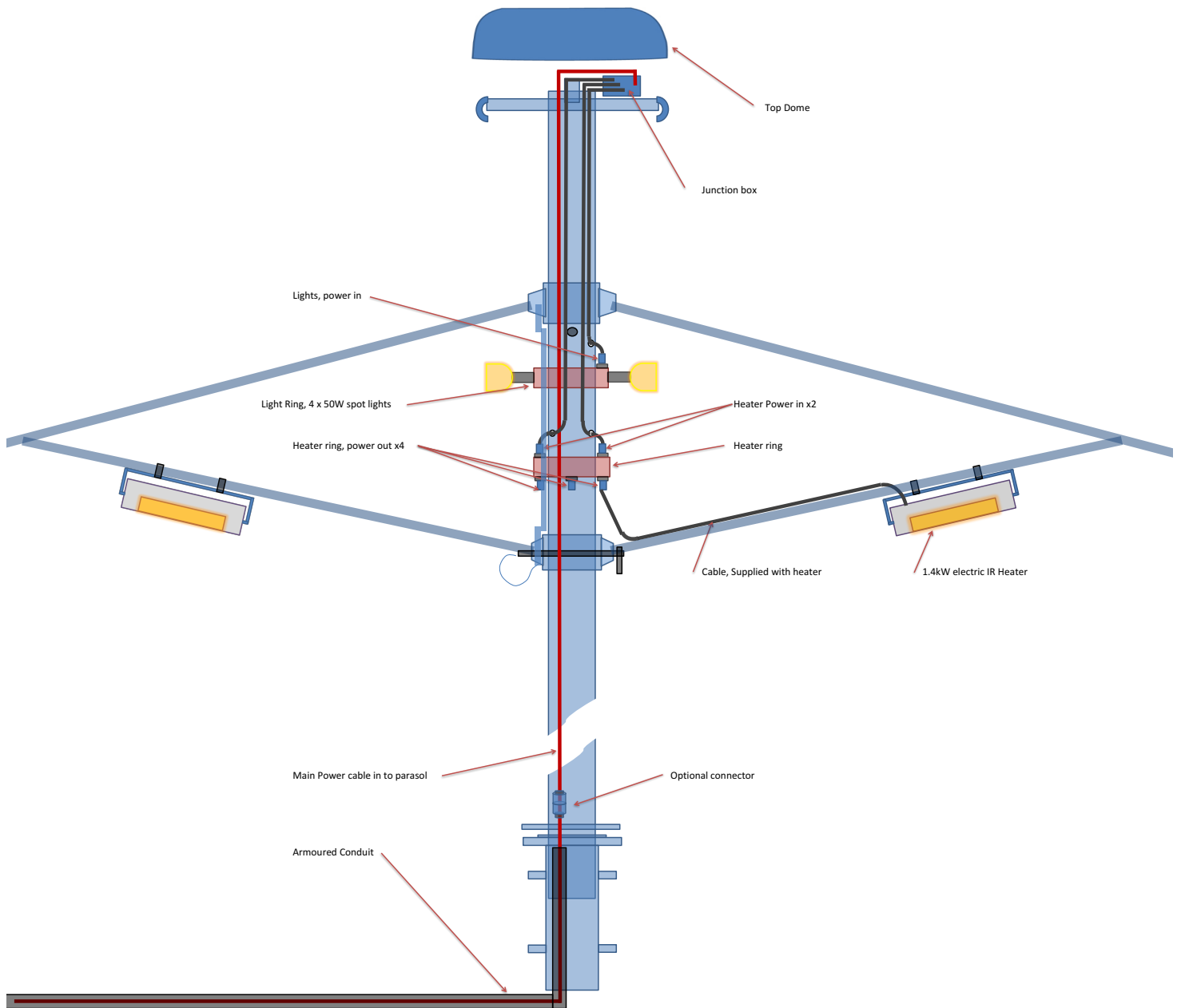

# Vortex circuit diagrams

## Suggested circuit diagram

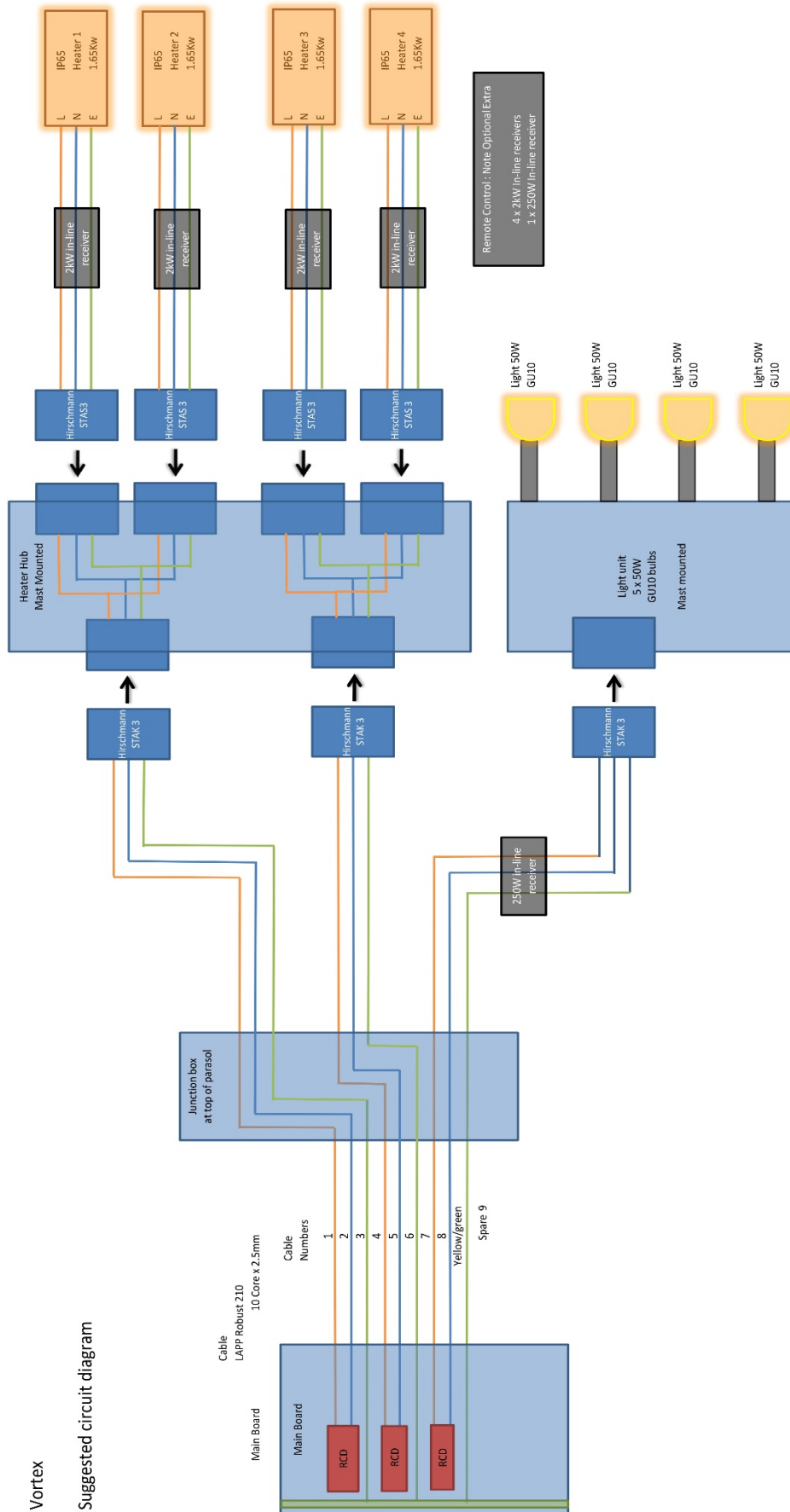

Vortex  
Suggested circuit diagram

# 5 Core cable circuit diagram

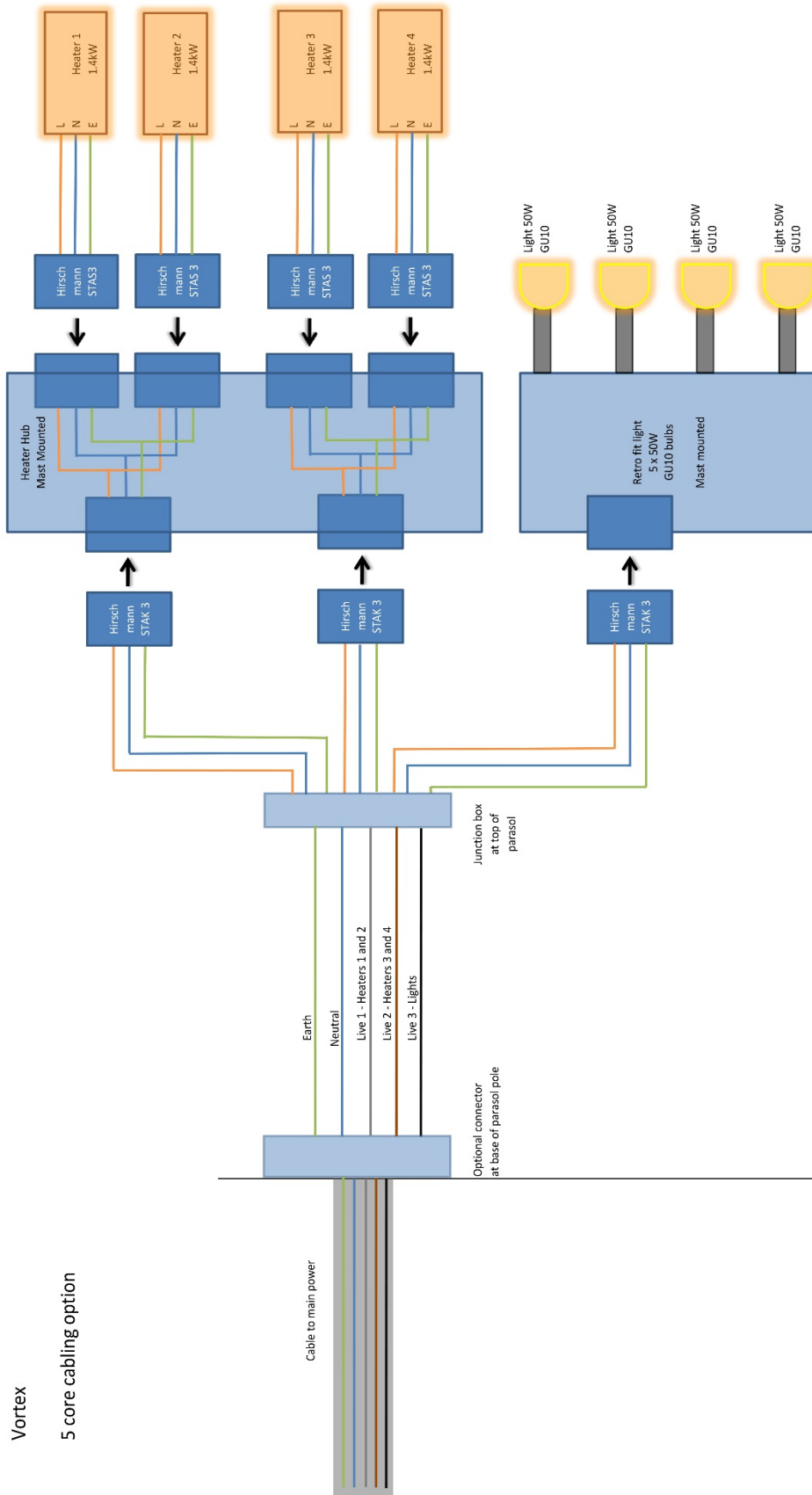

All parts above supplied by Global Parasols

Parts to be supplied by third party

# Retro fit heat and light circuit diagram

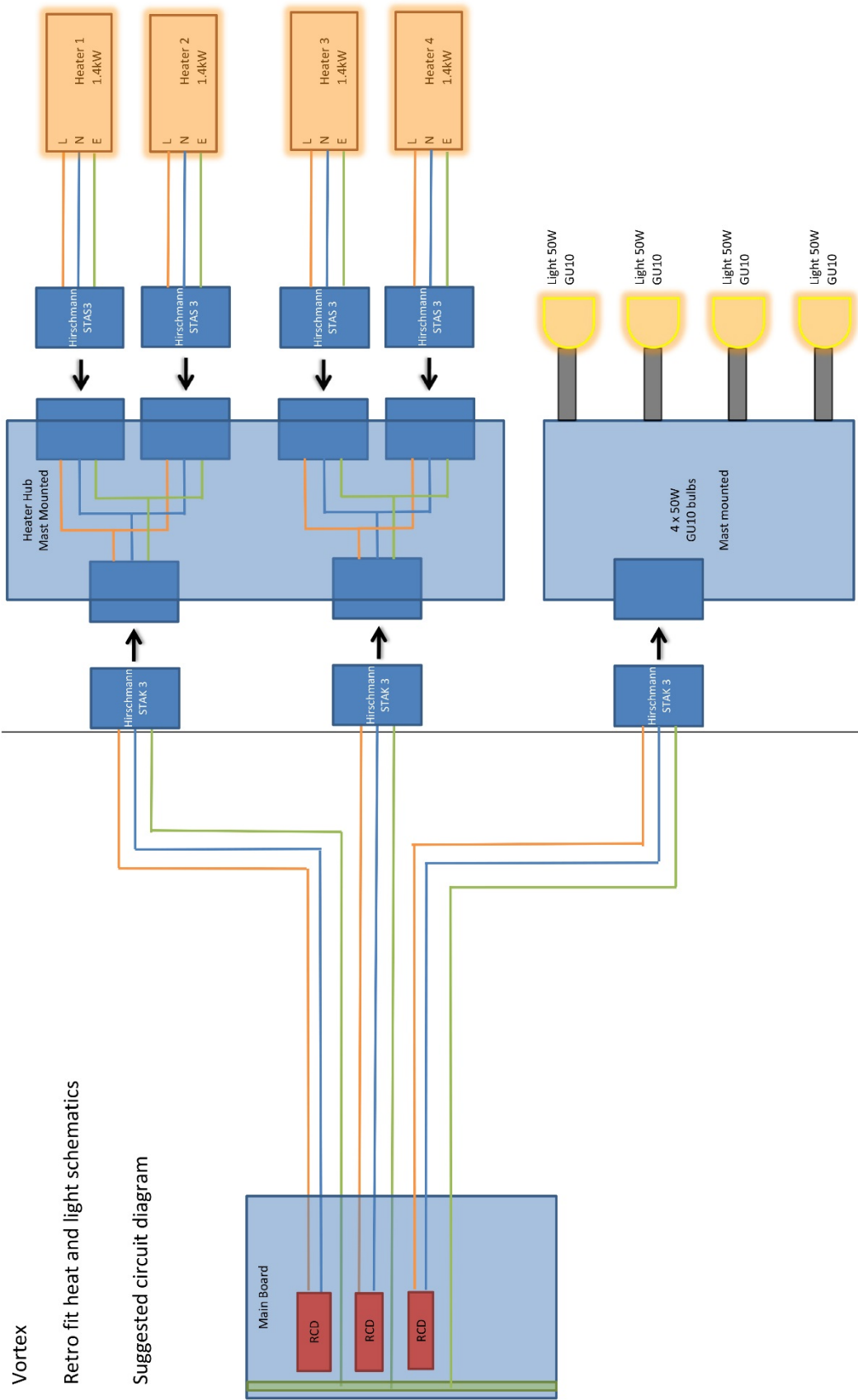

Vortex

Retro fit heat and light schematics

Suggested circuit diagram

Parts supplied by Global Parasols

Parts to be supplied by third party

