

markilux 970

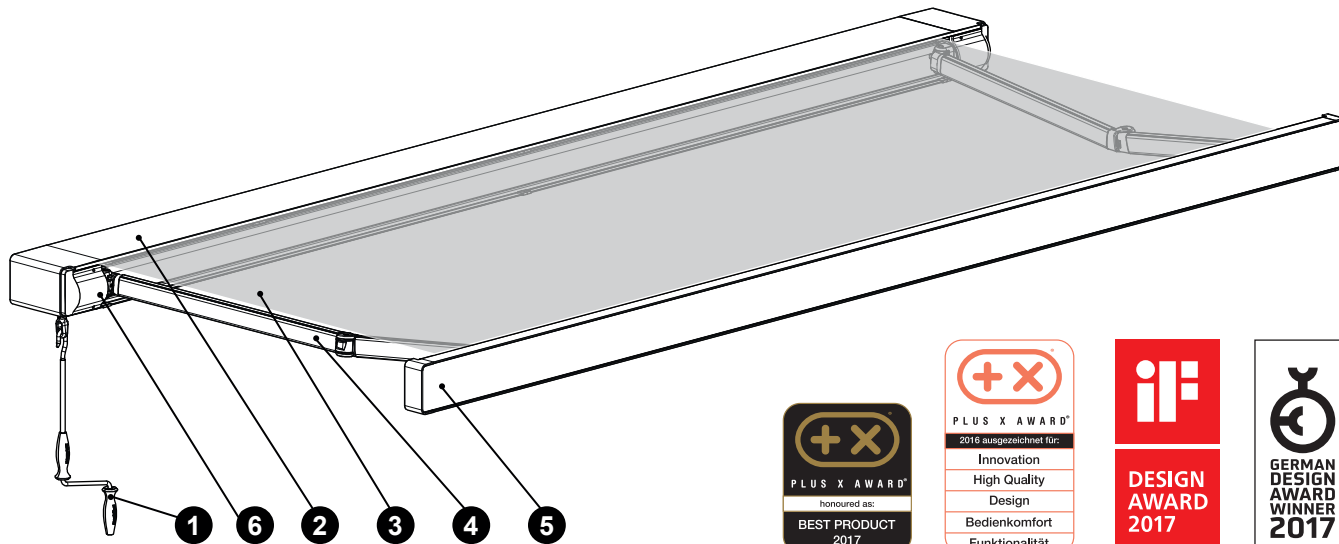

with LED spotlights (optional)

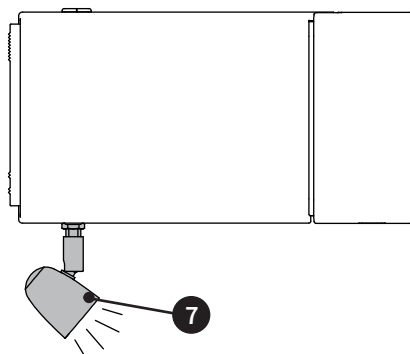

with LED line (optional)

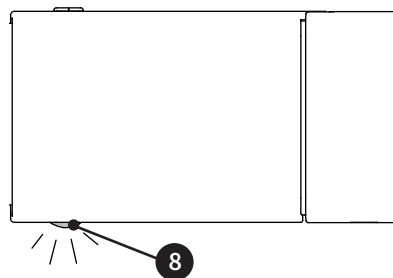

with shadeplus (optional)

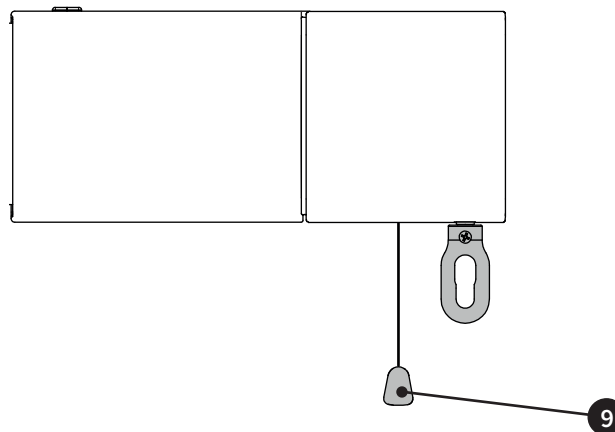

- | | |
|---|---|
| 1 | Hand crank for manual operation |
| 2 | Cassette |
| 3 | Cover |
| 4 | Folding-arm |
| 5 | Front profile |
| 6 | Swivel joint for pitch adjustment of the awning cover |
| 7 | LED spotlights (optional) |
| 8 | LED line (optional) |
| 9 | Shadeplus (optional) |

Table of contents

markilux important notes	
markilux operating instructions	
	Page
1 Reading the instructions	7
2 Awning with manual operation	7
3 Awning with motorised operation	8
4 Modification or retrofitting	8
5 What you should also know	8
6 Awning with shadeplus (optional)	9
6.1 Manual operation shadeplus	9
6.2 Motorised operation shadeplus	9
7 Awning with lighting (optional)	10
8 Replacement of a faulty illuminant for lighting	11
8.1 Overview replacement parts lighting LED spotlights	11
8.2 LED spotlights in the projection profile	11
9 Maintenance and care	12

markilux important notes

Important information for the users of markilux awnings

1. Manufacturing number

Every markilux awning was produced individually according to your guidelines and has a fabrication number on it, through which this product becomes a unique product identifiable at any time.

2. Marking of important safety instructions



With this triangular warning, notes regarding dangers are marked which can result in bad injuries or even death. Furthermore it marks important information on the function of the awning!



With this triangular warning, notes are marked which respond to dangers by electric shock resulting in bad injuries or even death.

3. Reading of "Important Instructions" and the "Operating Instructions"

The instructions handed by the authorized markilux specialist must be read before the first awning use. It is important to read all instructions for the safety of persons. All instructions are to be stored by the customer and have to be handed over to the new owner in case of an eventual transfer of the awning to Third Parties.

4. Proper use of an awning

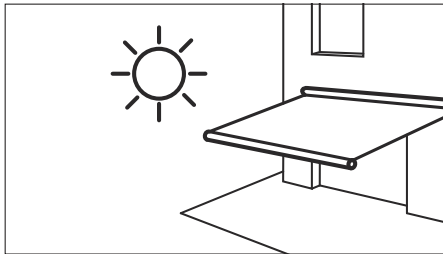

The awning is a sun protection construction. Improper use may lead to significant hazards.



If the awning inclination is less than 25% = 14° measured at the horizontal or the awning is not extended entirely, then it must not be burdened by rainwater. If this is the case, there is a risk of the formation of water troughs in the awning cover and the awning may become damaged or even detached from the wall.

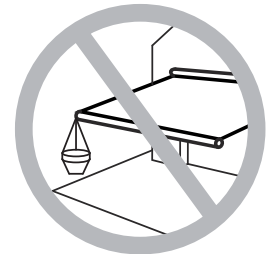

Alterations like rebuilding or enlargements which are not intended by the manufacturer may only be carried out with the markilux manufacturers written approval. Additional awning burdens by means of object attachments or rope wearing can result in damage or dropping of the awning and are therefore not allowed.

5. Wind resistance class

Wind resistance class	0	1	2	3
Wind speed V (km/h) maximum values	< 28	28	38	49
Wind speed V (m/s) maximum values	< 7.8	7.8	10.6	13.6

wind resistance class 2

markilux folding-arm awnings: 6000 / 5010 / 3300 / 970 / 990 / 1700 / 1710 / 1600 / 1650 / 930 / 1300 / MX-1 / MX-1 compact / MX-3 / ES-1

markilux 625 (depending on the size) 710 / 810, 720 / 820, 730 / 830, 740 / 840, 750 / 850, 893, 776 (depending on the size), 876 (depending on the size), 779 (depending on the size), 879 (depending on the size), 8850

wind resistance class 3

markilux 620, 625 (depending on the size), 776 / 776 tracfix (depending on the size), 876 / 876 tracfix (depending on the size), 779 / 779 tracfix (depending on the size), 879 / 879 tracfix (depending on the size), 770, 870, 8800, pergola, pergola compact, markant



The awning meets the requirements of the above stated wind resistance class. **Explanation see "Handover certificate from the specialist dealer"**. The CE indicates that correspondence with the requirements of the applicable European directives is proven. The corresponding declarations of performance and EU declarations of conformity can be requested through the markilux specialist dealer.

6. Use in case of snow, ice, thunderstorm, storm and absence, also with automatic control



The awning must not be extended at snowfall or risk of frost. There is risk of the awning to be damaged or crash down. When a storm or bad weather front is approaching, severe gusts of wind can occur suddenly to which even an automatic control mechanism cannot react with sufficient speed. An automatic control enhances the awning comfort, but does not excuse from the duty of care! During absence for longer periods, e.g. holidays or during the night, an automatic control system does not guarantee an enduringly faultless operation of your awning.



⚠ Attention! It is recommended to retract the awning before freezing wetness starts, at approaching storm respectively bad weather fronts or at absences. A possibly existing automatic function is to switch off!

7. Leaves, snow and foreign bodies

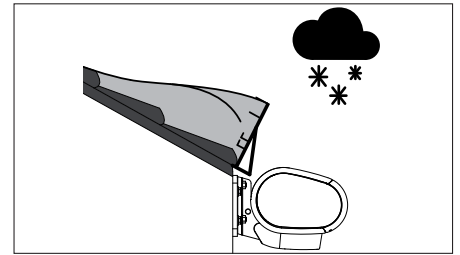

Foliage and other foreign objects located on the awning cover, inside the awning box and in the guidance bars are to remove immediately. There is risk of the awning to be damaged or crash down. Snow accumulation behind the awning must be avoided by installing a snow guard (snow fence or similar) or by regularly removing the snow load.

8. Obstacles

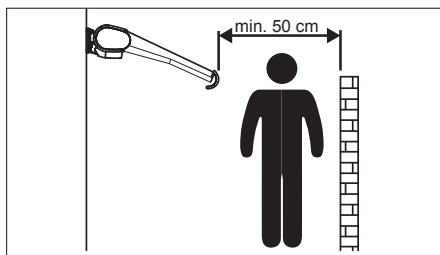

In the awning extension area, no obstacles may be located. There is danger for persons to be squashed in there. In order to avoid this, a safety distance of at least 50 cm has to be observed.

9. Motor in the event of a power-cut

A motor-driven awning cannot be retracted without electricity. In very windy areas with frequent power cuts the use of an emergency power supply should be considered. Otherwise always retract the awning if the power is scheduled to be cut!

10. Uncontrolled operation during cleaning and maintenance jobs

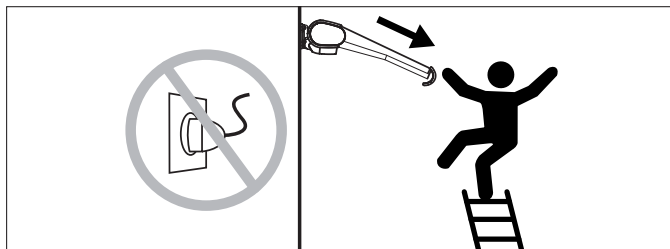

⚠ Attention! When working in operation radius (e.g. cleaning or service works), make sure the awning to be currentless (e.g. power switch off, remove plug coupling at drive cable, ...) There is risk of squeezing and falling down.

There is a risk of crushing body parts and falling. For works on manually operated units the crank should be removed and stored safely. If awnings are operated by various persons, a locking device switching of prime importance (controlled circuit breakers from outside) must be actuated, so that every awning retraction and extension is made impossible. Persons not familiar with proper awning use must not operate them.

11. Repair and spare parts

The awning is to be checked regularly for signs of wear or damage at covering, frame and its fixtures (with electric connection: also the power supply lines). The durability of the fixtures should be checked on an annual basis by means of a visual inspection or by an annual servicing of the markilux specialist dealer. If damages occur, an authorised markilux specialist dealer is to be entrusted with the adjustment. Only spare parts released by the manufacturer may be used.

⚠ Attention! Risk of injury! Please never try to repair disorders on your own! Awnings which need to be fixed must not be used. Talk to your authorized markilux specialist about a preventive maintenance agreement!

12. Crushing and shearing zones



⚠ Attention! Depending on the type of awning there are crush and shear zones, e.g. between front profile and cassette and between moving parts. Items of clothing or limbs can be grabbed by the unit and pulled in. If the awning is assembled at a height less than 2,5 metres above accessible traffic ways, then the awning may only be actuated by a pushbutton switch which allows viewing the moving parts. Electric controls, radio-controlled motors with click in-switches are not permitted for such installations.

13. Metallic and pearl glimmer coatings of the awning frame

The look of plastic coatings of metal and plastic parts in metallic and/or pearl glimmer colour vary. These visual differences concern in particular the intensity and characteristic of the metallic effect, which may also lead to a change in the perception of the basic shade.

14. Disassembly and disposal

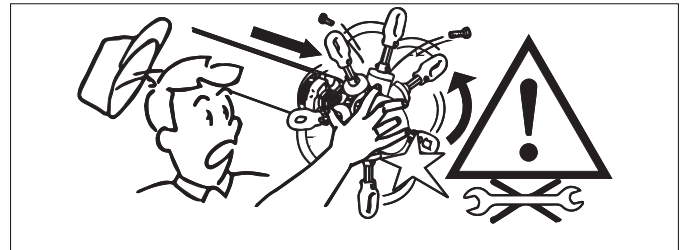
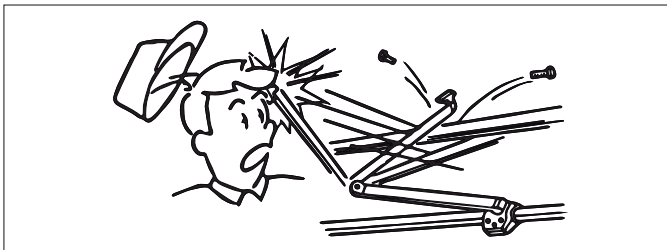

⚠ Attention: Risk of injury! When disassembling and disposing of the shading system, the parts under tension (e.g. folding-arms, counter tension systems or servo gear unit) have to be relaxed completely or secured beforehand. A markilux specialist should be commissioned for this!

15. Maintenance and care, characteristics cover and awning frame

Whether a cleansing is necessary or not depends strongly on environmental influences (traffic, air pollution, industrial gases etc.). Depending on the degree of pollution, a regular cleansing is recommended.

⚠ Attention! Always use an appropriate ascending aid and never rest again or attach to the awning!

15.1 Awning cover in wet condition

If possible, retract the awning when it is dry only! If the awning must be retracted wet, it has to be extended as soon as possible in order to dry. By the cover permanent weight, a deflection is possible which increases in wet condition. This occurrence does not influence the awning function and running qualities.

15.2 Cleaning the awning cover

The awning cover is equipped with special impregnation which reduces at every cleansing. For post-impregnation, commercial tent impregnation can be used. By re-impregnation, no new condition of the cover can be achieved yet.

Remove dust periodically with a soft brush in dry condition. Remove leaves, twigs and similar debris immediately. Remove small stains on the awning cover with commercial, preferably liquid mild detergent added to water (water temperature approx. 30°C, soap solution 5 %). Rinse thoroughly with water until all traces of the detergent have been removed.

15.3 Cleaning the awning frame

For cleansing of the awning frame, use commercial detergent for sensitive surfaces (pH-value between 5 and 8). Aggressive acids and scraping materials (like grinding fleece, emery, sand, pumice, etc.) are not allowed because they could alter the surface totally.

15.4 Characteristics resulting from the production and manufacture of awning fabrics

Awning covers are industrially manufactured textile products which serve both a functional and a decorative purpose. Although only first-class, quality controlled fabric is used in production, there are limits to the degree of perfection that can be achieved. Awning owners occasionally complain about certain imperfections in the fabric due to lack of knowledge. Defects actually to complain are only those which influence the cover life span. The following specified imperfections influence the awning cover durability and usage practicality in no way.

• Dogleg and wrinkle creases

At processing, like e.g. trimming, sewing and winding up of the cover onto the awning frame, dogleg traces can result which can not be avoided. Viewed against the light, the user of the awning has the impression that he sees dark stripes.

• Chalk and write effect

As with the previously mentioned processes, the cover may show a light change in colour (pigment shifting) at folded spots caused by kinking the fibre.

• Winding folds / waviness

Winding folds/rippling: This occurs due to the permanent coiling and uncoiling of the cover on the roller. This effect can be explained by the fact, that the material is thicker close to the seams, coils more loosely between the seams of the cover. This effect can occur both directly next to the seam as well as also in the middle of web.

• Other irregularities

Irregularities caused by the production process which cannot be avoided, such as

- Knots, thread thickening and thinning, which can be seen in the cloth as points of light or as nubs
- Colour deviations in cloths produced in webs (e.g. in triangular shades)
- Individual thread breakages and expansions at the seams with resulting sagging
- Sagging of the cloth due to its own weight or after the formation of a "water sack".

can occur, and are unavoidable in production.

15.5 Flexing of the awning frame

The profile of the wider systems' awning frame can flex as well because of own weight. This occurrence does not influence the awning function and running qualities.

16. Tested awning cover

The certificate "STANDARD 100 by OEKO-TEX®" guarantees that markilux awning covers made from sunsilk snc and sunvas snc do not contain any harmful dyes or chemicals.

UPF = Ultraviolet Protection Factor

Fabrics made of sunsilk snc and sunvas snc achieve the highest possible solar protection factor for textiles (UPF 50+). An awning fabrics with an ultraviolet protection factor of 50+ enables you to sit out safely in the sun fifty times longer than you would otherwise be able to do without suffering sunburn, if you were to rely solely on the protection provided by your skin.

Max. duration of sunbathing under your awning = own protection time x 50

Test mark "Selfcleaning inspired by nature"

Awning fabrics made from sunvas snc and sunsilk snc offer a self-cleaning effect in rain (a minimum of 14° awning pitch is required to ensure water run-off).

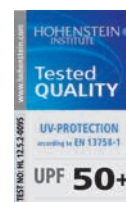

17. Legal disclaimer

The graphics and text sections in these instructions have been created with care. No liability can be borne for any errors and their effects. We reserve the right to undertake technical modifications to the product and to these instructions! The instructions contain copyright-protected information. All rights reserved! The listed product or trade names are copyright trademarks.

Operation manual

markilux 970

1 Reading the instructions

Attention!

Read the operating instructions and all the documentation pertaining to the product (handover protocol), important guidelines, etc.) carefully and completely before using the product.

2 Awning with hand crank operation

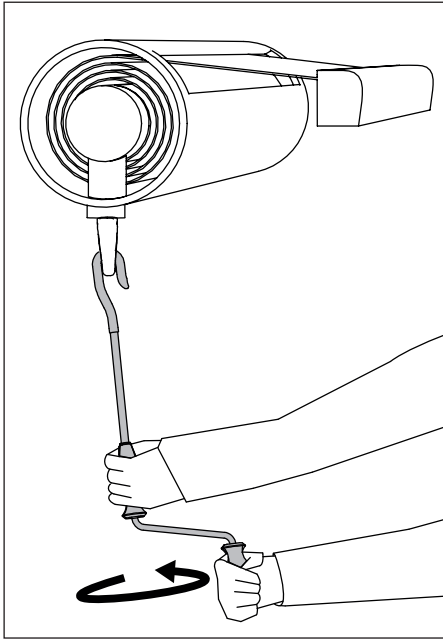

1. Attach the crank-hook into the gear eyelet.
2. Hold the crank rod with one hand on the upper and one hand on the lower turning handle. During the operating procedure, pull the crank slightly towards the operator.
3. If the gear eyelet is positioned on the left side (as shown here):
 - Extension of the awning cover: Clockwise rotation of the crank.
 - Retraction of the awning cover: Counterclockwise rotation of the crank.
 - If the gear eyelet is on the right side, the directions of rotation are exactly the opposite.
4. If the crank is to remain in the gear eyelet, it must be protected against uncontrolled movements (e.g. when it is windy).

 **Attention:** In partially extended positions and with flat pitch angles (less than 14°) there is an increased risk of water collecting on the surface of the cover. The optimum cover tension is achieved when the awning is extended.

Attention!

Awnings with manual operation have a gear limit switch to limit the extension travel. It prevents incorrect coiling of the cover onto the roller. The transmission end stop must never be approached with force. Shortly before reaching the end position in the extending direction, the crank operation should be slowed in a controlled manner in order to avoid a forced overtravel of the transmission brake. If the transmission end stop is defective, a coiling of the cover from below onto the roller during retracting can lead to damage to the awning cover and the awning frame.

Attention!

The transmission brake cannot be adjusted precisely. If the cover sags when fully extended (Fig. 1), draw the awning back in again until the cover is tense. (Fig. 2).

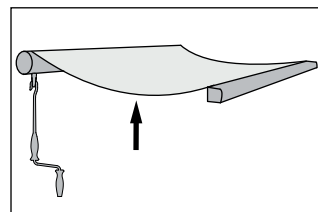
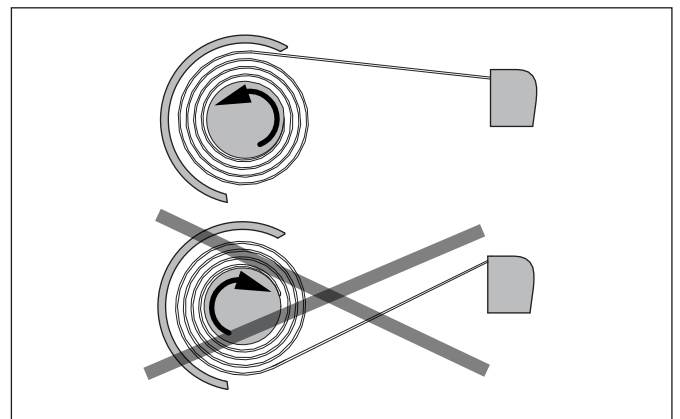

Fig. 1

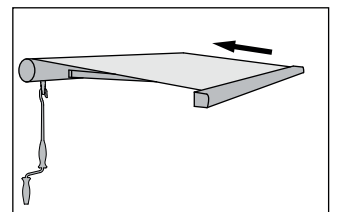

Fig. 2

3 Awning with motorised operation

Extend the awning by actuating the pushbutton switch for extension / retraction. With radio-controlled operation, your markilux specialist must exactly explain the functions on the radio remote control to you, since, depending on the equipment, he can set these for you individually.

Here observe the separate operating instructions of the motor and, if available, the controller manufacturer. The final stop for awning extension / retraction is limited. The end stop for the extension direction will be set by your specialist dealer.

Protection against overheating:

Multiple extension and retraction of the awning in rapid succession results in an automatic motor switch-off to preserve it from overheating. After cooling down the motor switches itself on again in operating readiness.

Attention!

In a partially extended position and with shallow inclinations (less than 14°), the danger of water accumulation on the fabric's surface is greater. The optimum cover tension is achieved when the awning is extended.

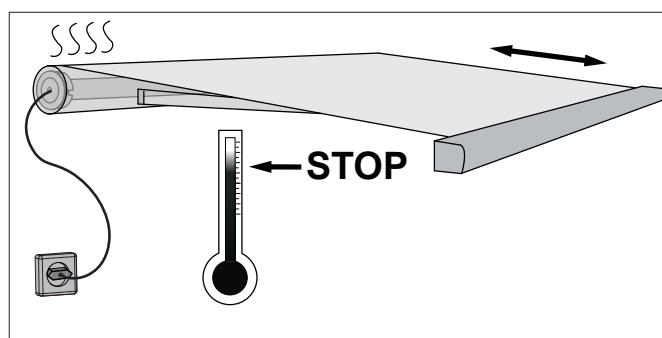
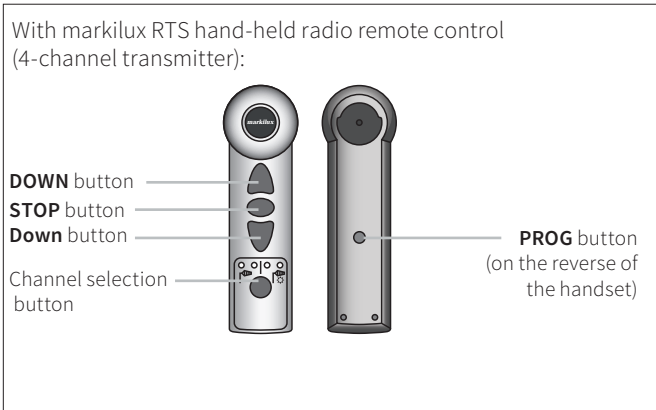

4 Conversion or retrofitting

The following modifications can be carried out retrospectively on your awning by your markilux specialist.

- Replacement of the awning fabric
- Installation of a motor
- Retrofitting an automatic control system. In principle a motor drive must be available. Ask your specialist retailer about sun and wind sensors, remote control, Vibrabox etc.

5 What else you should know

Due to the compact awning construction and depending on the width and the projection, contact between cover and folding arms may occur during extension and retraction. This has no detrimental effect on the functionality and / or durability of the awning.

6 Awning with Shadeplus (optional)

6.1 Manual operation Shadeplus

1. Attach the crank-hook into the gear eyelet.
2. Hold the crank rod with one hand on the upper and one hand on the lower turning handle. During the operating procedure, pull the crank slightly towards the operator.
3. If the gear eyelet is on the left side:
 - Extension of the awning cover: Clockwise rotation of the crank.
 - Retraction of the awning cover: Counterclockwise rotation of the crank.
 - If the gear eyelet is on the right side, the directions of rotation are exactly the opposite.
4. If the crank is to remain in the gear eyelet, it must be protected against uncontrolled movements (e.g. when it is windy).
5. Direction of rotation during retraction shadeplus: If the winding direction is wrong, the shadeplus profile will not close flush with the projection profile.

Tip: If the shadeplus profile does not retract flush into the projection profile, extend the shadeplus cover completely and retract with the same rotary movement of the crank. Afterwards operate the crank in the opposite rotating direction when extending and retracting.

6.2 Motor operation Shadeplus

The instructions mentioned under point 3 are to be adhered to.

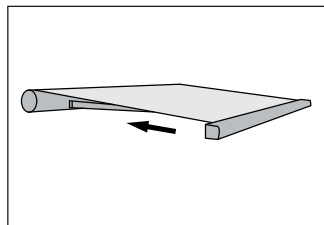
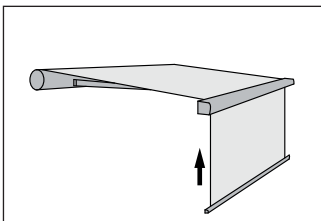

⚠ Attention: Always retract the shadeplus cover first before retracting the entire awning. If the main motor of the awning is equipped with a controller, never leave your extended shadeplus cover unattended, because the awning could retract unintentionally!

When it is windy, please take particular care that the shadeplus cover with its valance profile does not carry out any uncontrolled movements. Retract your shadeplus cover immediately if it gets windy.

7 Awning with lighting (optional)

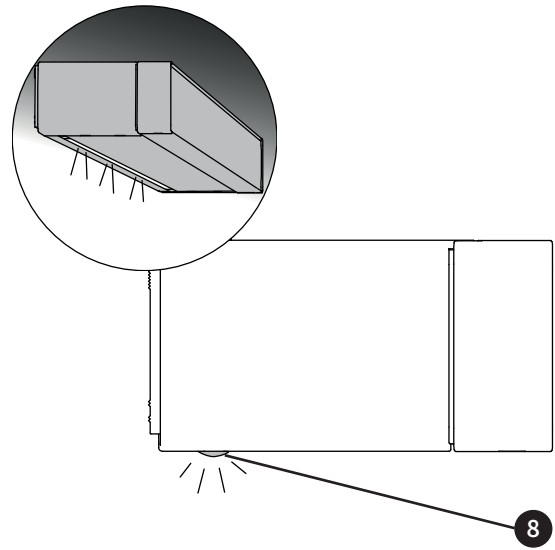
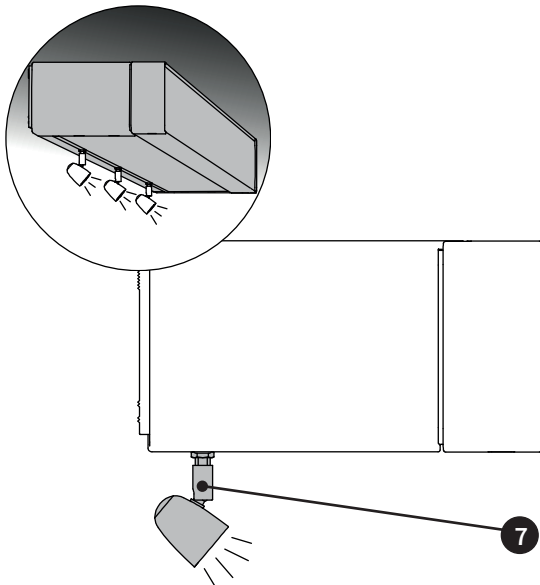

7 LED spotlights (optional)

8 LED line (optional)

⚠ Attention - risk of injury!

The LED lights can heat up a lot! The lighting has to be switched off for some minutes to cool down before you touch the individual lamps.

⚠ Attention: You must never hang any objects or similar in front of the lamps, and it should be ensured that there are no objects immediately underneath the projection profile both in retracted and in extended state. Observe in particular the safety clearances in "Important notes".

⚡ Attention - danger of fatal injury!: Do not grab or pull the mains leads (230 V) or cables visible at every movement point of the folding arm! Do not suspend any objects from these mains leads!

The mobility of the mains lead is limited in temperatures below zero. Therefore it has to be ensured, whether the electrician has protected the connection of your lighting via an RCCB (30mA), so that any eventual cable breakage does not pose any hazard.

⚠ Attention: For safety reasons, the electronic transformer switches off automatically at a temperature of 80°C, and switches on again after an appropriate cooling down period.

Automatic switch-off: The spotlights switch off automatically using the integrated timer (io-homecontrol technology: after **6 hours**; RTS wireless technology: after **24 hours**). The lighting can be reactivated by double-clicking either the switch or the remote control.

The **radiation intensity** of these LED lamps is harmless to people and underruns the RG 2 area acc. EN 62471. However, it is suggested not to look for a long time at the centre of the light source.

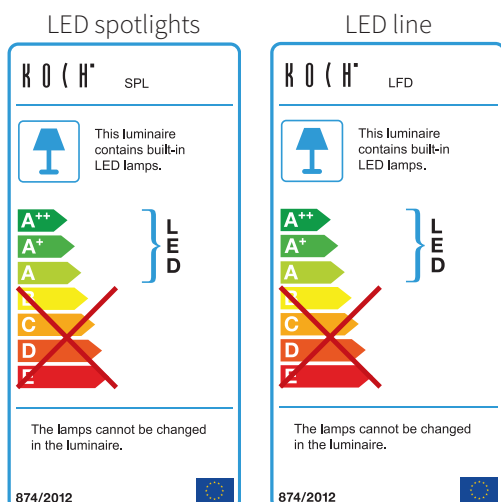

EU energy label according to EU directive 874/2012:

Energy efficiency A is very efficient, E is inefficient. The markilux LED spots and LED line are assigned to energy efficiency category A.

8 Replacement of a faulty illuminant for lighting

These instructions for the replacement of defective illuminants at your markilux folding-arm awning is to be read and observed.

Exclusively LED lights, which have a very long service life are used for the lighting of your markilux 970.

⚠ Attention: Check the awning regularly for signs of wear and tear at cables and lamps. If damages occur, an authorized markilux specialist is to be entrusted with the adjustment.

Awnings which need to be fixed must not be used. Only spare parts released by the markilux may be used.

⚡ Attention: Electrical installations or repairs are to be carried out in accordance with the installation regulations DIN VDE 0100 by a qualified electrician only.

⚠ Attention: The lighting system must be disconnected from the electricity supply during work on the system (unplug, switch off fuse). Switch on the illumination only when all cable connections have been established completely.

**In case of a defective LED line, kindly contact your specialised dealer.
If an LED spotlight is defective you can change it yourself.**

8.1 Overview replacement parts lighting LED spotlights

The following replacement parts are available via your markilux specialist dealer:

chapter	Lighting type	Article no.
8.2	1 piece LED spotlight with plug in projection profile	714881

8.2 LED spotlights in the projection profile

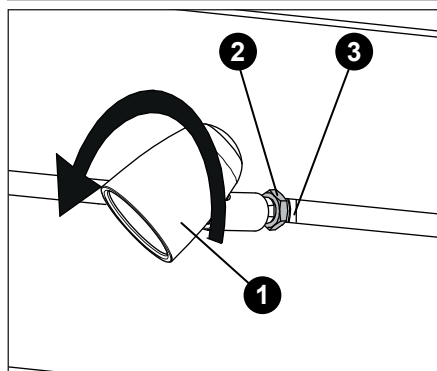

1. Loosen the hexagon nut (2) with a SW 13 spanner. Subsequently, turn the defective LED spotlight (1) anti-clockwise by 90° to bring the pincher carriage (3) in running direction of the groove and remove.

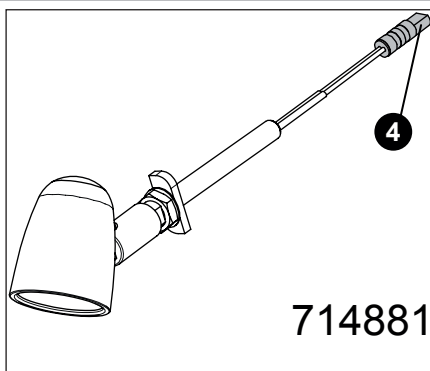

2. Disconnect the plug (4) of the defective spot light from the mains and plug in the new spot light.

Article no. new LED spotlight with plug:
714881

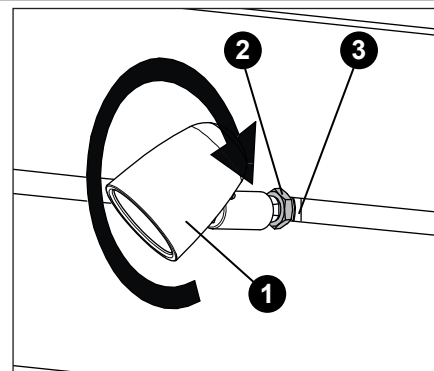

3. Place the new LED spotlight (1) into the track, turn clockwise by 90° to hook the pincher carriage (3) in the groove. Subsequently retighten the hexagon nut (2).

9 Maintenance and care

For proper cleaning of the awning cover and the awning frame of your markilux awning, kindly pay close attention to the cleaning instructions in chapter "Important notes".

 Dirty profiles should always be cleaned with water. Use mild soaps or detergents suitable for delicate fabrics in lukewarm water. Abrasive cleaners, strong detergents, spray cleaner for glass, scouring cloths or brushes as well as solvents such as acetone, carbon tetrachloride, paint thinner or alcohol mixtures with more than 5% alcohol content may be aggressive to the surface and should never be used.