

Operating instructions folding-arm awnings

markilux 1600 / 1600 stretch / 1650

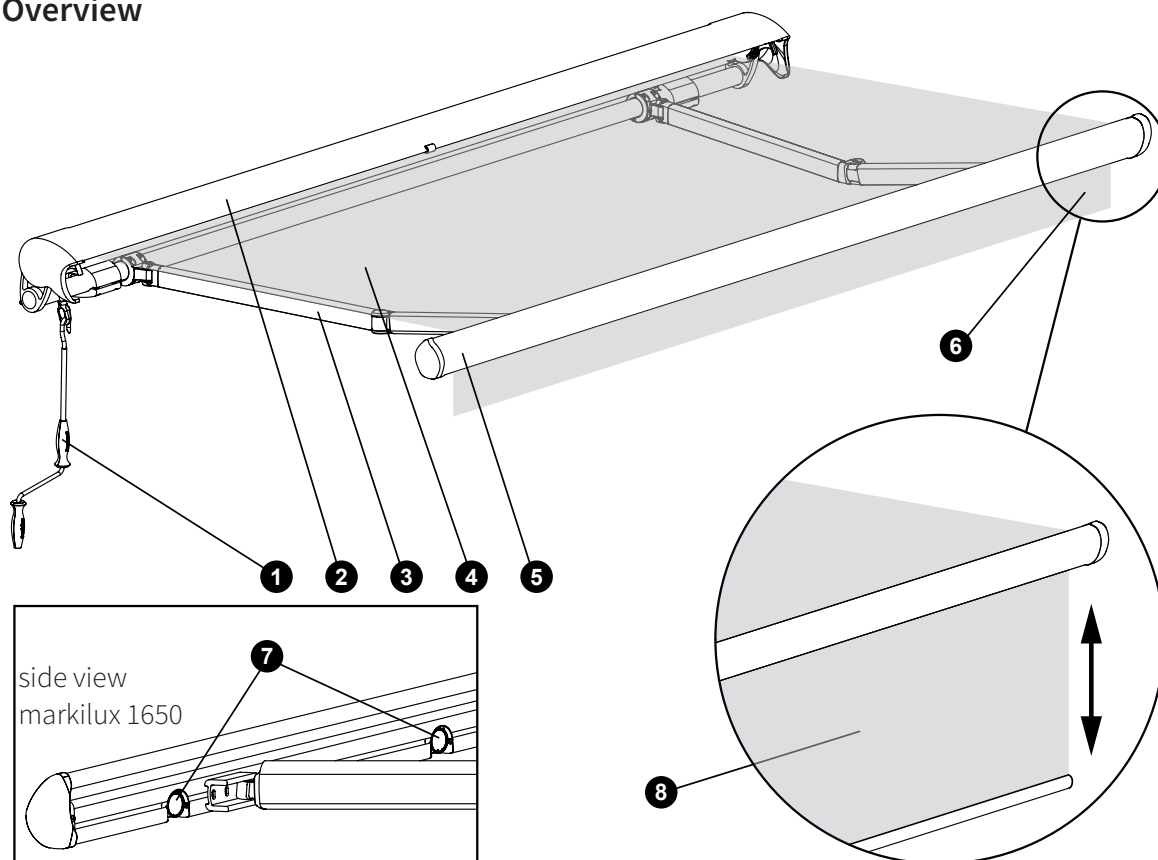

Overview



- 1 Hand crank (for manual operation)
- 2 Pent roof
- 3 Folding-arm
- 4 Cover

- 5 Front profile
- 6 Valance
- 7 Lighting (only for markilux 1650)
- 8 shadeplus (optional for markilux 1600 / 1600 stretch)



Table of contents

markilux important notes

markilux operating instructions

	Page
1. Reading the instructions	7
2. Awning with manual operation	7
3. Awning with motorised operation	8
4. Modification or retrofitting	8
5. What you should also know	8
6. Awning with shadeplus markilux 1600 / 1600 stretch	9
6.1 Manual operation shadeplus	9
6.2 Motorised operation shadeplus	9
7. Safety note	10
8. Awning with lighting markilux 1650	10
8.1 Important advice!	10
8.2 Spare part LED spot	11
8.3 Replacement of an LED spot	12
8.4 Operation	12

markilux

markilux important notes

Important information for the users of markilux awnings

1. Manufacturing number

Every markilux awning was produced individually according to your guidelines and has a fabrication number on it, through which this product becomes a unique product identifiable at any time.

2. Marking of important safety instructions



With this triangular warning, notes responding to dangers are marked which can result in bad injuries or even death. Furthermore it marks important information on the function of the awning!



With this triangular warning, notes are marked which respond to dangers by electric shock resulting in bad injuries or even death.

3. Reading of "Important Instructions" and the "Operating Instructions"

The instructions handed by the authorized markilux specialist must be read before the first awning use. It is important to read all instructions for the safety of persons. All instructions are to be stored by the customer and have to be handed over to the new owner in case of an eventual transfer of the awning to Third Parties.

4. Proper use of an awning

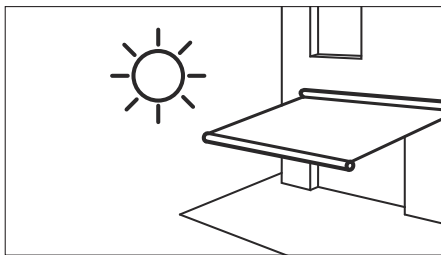

The awning is a sun protection construction. Improper use may lead to significant hazards.

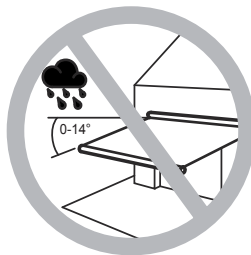

If the awning inclination is less than 25% = 14° measured at the horizontal or the awning is not extended entirely, then it must not be burdened by rainwater. There is a risk of the formation of water pockets in the awning cover and the awning may be damaged or fall.

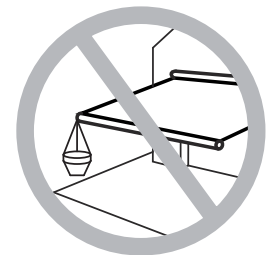

Alterations like rebuilding or enlargements which are not intended by the manufacturer may only be carried out with the markilux manufacturers written approval. Additional awning burdens by means of object attachments or rope wearing can result in damage or dropping of the awning and are therefore not allowed.

5. Wind resistance class

Wind resistance class	0	1	2	3
Wind speed V (km/h) maximum values	< 28	28	38	49
Wind speed V (m/s) maximum values	< 7.8	7.8	10.6	13.6

Wind resistance class 2

markilux folding-arm awnings, markilux 710/810, 720/820, 730/830, 740/840, 750/850, 893, 776/776 tracfix (depends on size), 876/876 tracfix (depends on size), 779/779 tracfix (depends on size), 879/879 tracfix (depends on size), 625 tracfix (depends on size), 8850

Wind resistance class 3

markilux 620 tracfix, 625 tracfix (depends on size), 776/776 tracfix (depends on size), 876/876 tracfix (depends on size), 779/779 tracfix (depends on size), 879/879 tracfix (depends on size), 770 tracfix, 870 tracfix, 8800/8800 tracfix, pergola, pergola compact, markant

The awning complies with the wind resistance category requirements named in the CE conformity mark (explanation see "handover declaration"). The CE conformity mark states an agreement to be proved according to the valid European guidelines requirements, the corresponding declarations can be requested via the authorized markilux service centre.



6. Use in case of snow, ice, thunderstorm, storm and absence, also with automatic control



The awning must not be extended at snowfall or risk of frost. There is risk of the awning to be damaged or crash down. At approaching storm or bad weather fronts, severe gusts can occur suddenly to which even a control can not react immediately. An automatic control enhances the awning comfort, but does not excuse from the duty of care! During absence for longer periods, e.g. holidays or during the night, an automatic control system does not guarantee an enduringly faultless operation of your awning.



⚠ Attention! It is recommended to retract the awning before freezing wetness starts, at approaching storm respectively bad weather fronts or at absences. A possibly existing automatic function is to switch off!

7. Leaves, snow and foreign bodies

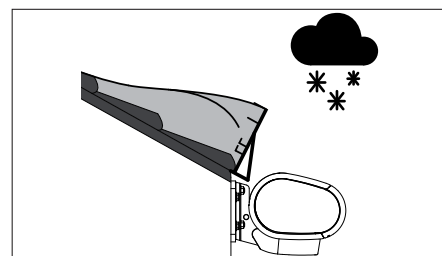

Foliage and other foreign objects located on the awning cover, inside the awning box and in the guidance bars are to remove immediately. There is risk of the awning to be damaged or crash down. A build up of snow behind the awning can be avoided by installation of snow stoppers (snow collecting grid or the like) or regular removal of the accumulated snow.

8. Obstacles

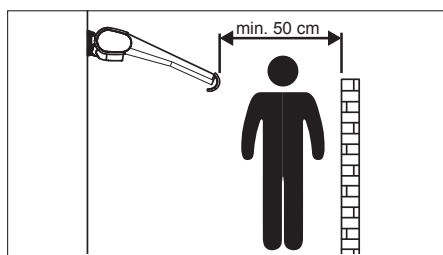

In the awning extension area, no obstacles may be located. There is danger for persons to be squashed in there. In order to avoid this, a safety distance of at least 50 cm has to be observed.

9. Motor in case of power cut

A motor-driven awning cannot be retracted without electricity. In very windy areas with frequent power cuts the use of an emergency power supply should be considered. Otherwise always retract the awning if the power is scheduled to be cut!

10. Uncontrolled operation during cleaning and maintenance jobs

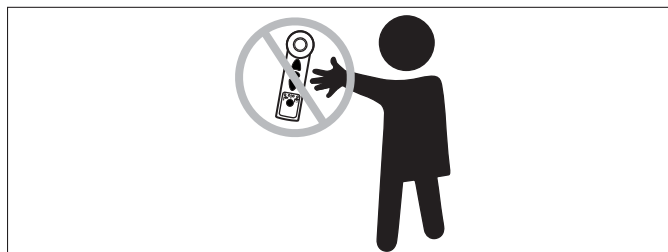
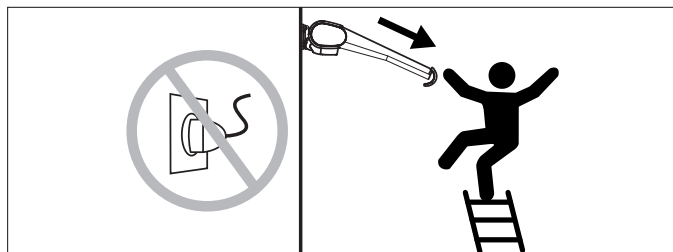

⚠ Attention! When working in operation radius (e.g. cleaning or service works), make sure the awning to be currentless (e.g. power switch off, remove plug coupling at drive cable, ...) There is risk of squeezing and falling down.

There is a risk of crushing body parts and falling. For works on manually operated units the crank should be removed and stored safely. If awnings are operated by various persons, a locking device switching of prime importance (controlled circuit breakers from outside) must be actuated, so that every awning retraction and extension is made impossible. Persons not familiar with proper awning use must not operate them.

11. Repair and spare parts

The awning is to check regularly for signs of wear or damage at covering, frame and its fixtures (with electric connection: also the power supply lines). The durability of the fixtures should be checked on an annual basis by means of a visual inspection or by an annual servicing of the markilux specialist dealer. If damages occur, an authorized markilux specialist is to be entrusted with the adjustment. Only spare parts released by the manufacturer may be used.

⚠ Attention! Risk of injury! Please never try to repair disorders on your own! Awnings which need to be fixed must not be used. Talk to your authorized markilux specialist about a preventive maintenance agreement!

12. Crushing and shearing zones



⚠ Attention! Depending on the type of awning there are crush and shear zones, e.g. between front profile and cassette and between moving parts. Items of clothing or limbs can be grabbed by the unit and pulled in. If the awning is installed at a height less than 2.5 metres above accessible traffic ways, then the awning may only be operated by a pushbutton switch which enables the moving parts to be viewed. Electric controls, radio-controlled motors with click in-switches are not permitted for such installations.

13. Metallic and pearl glimmer coatings of the awning frame

The look of plastic coatings of metal and plastic parts in metallic and/or pearl glimmer colour vary. These visual differences concern in particular the intensity and characteristic of the metallic effect, which may also lead to a change in the perception of the basic shade.

14. Disassembly and disposal

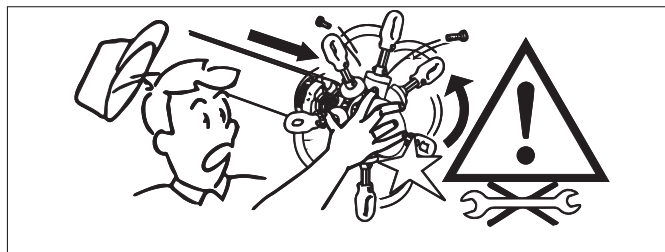
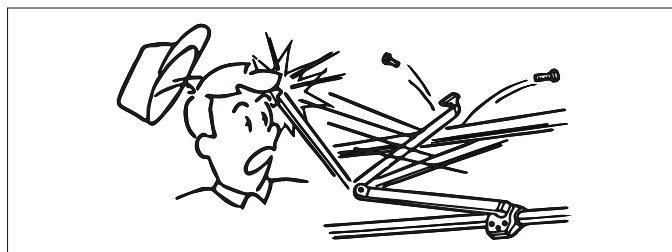

⚠ Attention: Risk of injury! When disassembling and disposing of the shading system, the parts under tension (e.g. folding-arms, counter tension systems or servo gear unit) have to be relaxed completely or secured beforehand. A markilux specialist should be commissioned for this!

15. Maintenance and care, characteristics cover and awning frame

Whether a cleansing is necessary or not depends strongly on environmental influences (traffic, air pollution, industrial gases etc.). Depending on the degree of pollution, a regular cleansing is recommended.

⚠ Attention! Always use an appropriate ascending aid and never rest again or attach to the awning!

15.1 Awning cover in wet condition

If possible, retract the awning when it is dry only! If the awning must be retracted wet, it has to be extended as soon as possible in order to dry. By the cover permanent weight, a deflection is possible which increases in wet condition. This occurrence does not influence the awning function and running qualities.

15.2 Cleaning the awning cover

The awning cover is equipped with special impregnation which reduces at every cleansing. For post-impregnation, commercial tent impregnation can be used. By re-impregnation, no new condition of the cover can be achieved yet.

Remove dust periodically with a soft brush in dry condition. Remove leaves, twigs and similar debris immediately. Remove small stains on the awning cover with commercial, preferably liquid mild detergent added to water (water temperature approx. 30°C, soap solution 5 %). Rinse thoroughly with water until all traces of the detergent have been removed.

15.3 Cleaning the awning frame

For cleansing of the awning frame, use commercial detergent for sensitive surfaces (pH-value between 5 and 8). Aggressive acids and scraping materials (like grinding fleece, emery, sand, pumice, etc.) are not allowed because they could alter the surface totally.

15.4 Characteristics resulting from the production and manufacture of awning fabrics

Awning covers are industrially manufactured textile products which serve both a functional and a decorative role. Although only first-class, quality controlled fabric is used in production, there are limits to the degree of perfection that can be achieved. Awning owners occasionally complain about certain imperfections in the fabric due to lack of knowledge. Defects actually to complain are only those which influence the cover life span. The following specified imperfections influence the awning cover durability and usage practicality in no way.

• Dogleg and wrinkle creases

At processing, like e.g. trimming, sewing and winding up of the cover onto the awning frame, dogleg traces can result which can not be avoided. Viewed against the light, the user of the awning has the impression that he sees dark stripes.

• Chalk and write effect

As with the previously mentioned processes, the cover may show a light change in colour (pigment shifting) at folded spots caused by kinking the fibre.

• Winding folds / waviness

Winding folds/rippling: This occurs due to the permanent coiling and uncoiling of the cover on the roller. This effect can be explained by the fact, that the material is thicker close to the seams, coils more loosely between the seams of the cover. This effect can occur both directly next to the seam as well as also in the middle of web.

• Other irregularities

Irregularities caused by the production process which cannot be avoided, such as

- Knots, thread thickening and thinning, which can be seen in the cloth as points of light or as nubs
- Colour deviations in cloths produced in webs (e.g. in triangular shades)
- Individual thread breakages and expansions at the seams with resulting sagging
- Sagging of the cloth due to its own weight or after the formation of a "water sack".

can occur, and are unavoidable in production.

15.5 Flexing of the awning frame

The profile of the wider systems' awning frame can flex as well because of own weight. This occurrence does not influence the awning function and running qualities.

16. Tested awning cover

The certificate "STANDARD 100 by OEKO-TEX®" guarantees that no harmful dyes or chemicals were used in the making of markilux sunsilk snc and sunvas snc awning covers.

UPF = Ultraviolet Protection Factor

Fabrics made of sunsilk snc and sunvas snc achieve the highest possible solar protection factor for textiles (UPF 50+).

An awning fabrics with an ultraviolet protection factor of 50+ enables you to sit out safely in the sun fifty times longer than you would otherwise be able to do without suffering sunburn, if you were to rely solely on the protection provided by your skin. Max. duration of sunbathing under your awning = own protection time x 50

Test mark "Selfcleaning inspired by nature"

Awning fabrics made from sunvas snc and sunsilk snc offer a self-cleaning effect in rain (a minimum of 14° awning pitch is required to ensure water run-off).



17. Legal disclaimer

The graphics and text sections in these instructions have been created with care. No liability can be borne for any errors and their effects. We reserve the right to undertake technical modifications to the product and to these instructions! The instructions contain copyright-protected information. All rights reserved! The listed product or trade names are copyright trademarks.

Operation manual

markilux 1600 / 1600 stretch / 1650

1. Reading the instructions

Attention!

Read the operating instructions and all the documentation pertaining to the product (handover protocol, important guidelines, etc.) carefully and completely before using the product.

2. Awning with hand crank operation

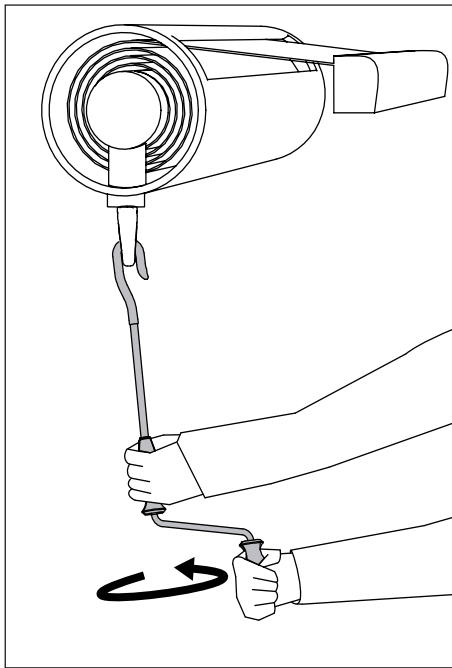

1. Attach the crank-hook into the gear eyelet.
2. Hold the crank rod with one hand on the upper and one hand on the lower turning handle. During the operating procedure, pull the crank slightly towards the operator.
3. If the gear eyelet is positioned on the left side (as shown here):
 - Extension of the awning cover: Clockwise rotation of the crank.
 - Retraction of the awning cover: Counterclockwise rotation of the crank.
 - If the gear eyelet is on the right side, the directions of rotation are exactly the opposite.
4. If the crank is to remain in the gear eyelet, it must be protected against uncontrolled movements (e.g. when it is windy).

 **Attention:** In partially extended positions and with flat pitch angles (less than 14°) there is an increased risk of water collecting on the surface of the cover. The optimum cover tension is achieved when the awning is extended.

Attention!

Awnings with manual operation have a gear limit switch to limit the extension travel. It prevents incorrect coiling of the cover onto the roller. The transmission end stop must never be approached with force. Shortly before reaching the end position in the extending direction, the crank operation should be slowed in a controlled manner in order to avoid a forced overtravel of the transmission brake. If the transmission end stop is defective, a coiling of the cover from below onto the roller during retracting can lead to damage to the awning cover and the awning frame.

Attention!

The transmission brake cannot be adjusted precisely. If the cover sags when fully extended (Fig. 1), draw the awning back in again until the cover is tense (Fig. 2).

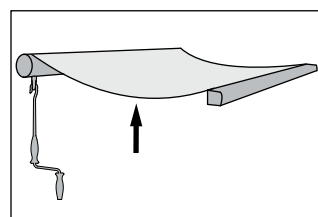
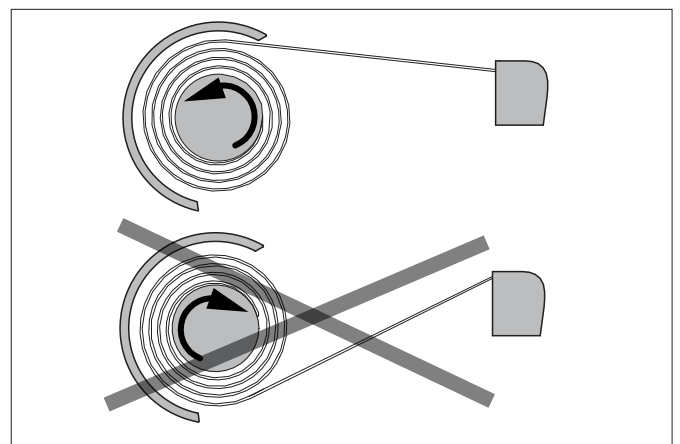

Fig. 1

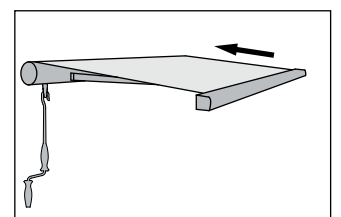

Fig. 2

3. Awning with motor drive

Extend the awning by actuating the pushbutton switch for extension / retraction. With radio-controlled operation, your markilux specialist must exactly explain the functions on the radio remote control to you, since, depending on the equipment, he can set these for you individually.

Here observe the separate operating instructions of the motor and, if available, the controller manufacturer. The final stop for awning extension / retraction is limited. The end stop for the extension direction will be set by your specialist dealer.

With markilux hand-held remote control (optional):



Protection against overheating:

Multiple extension and retraction of the awning in rapid succession results in an automatic motor switch-off to preserve it from overheating. After cooling down the motor switches itself on again in operating readiness.

Attention!

In a partially extended position and with shallow inclinations (less than 14°), the danger of water accumulation on the fabric's surface is greater. The optimum cover tension is achieved when the awning is extended.

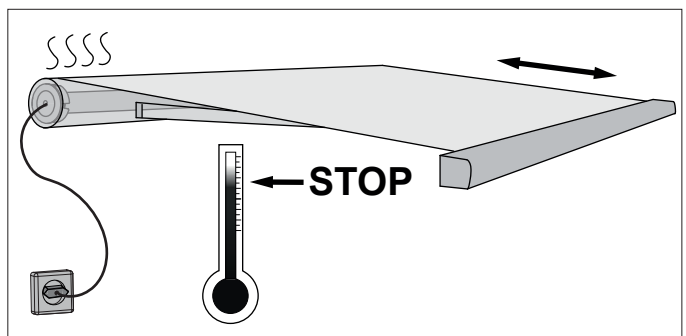

4. Conversion or retrofitting

The following modifications can be carried out retrospectively on your awning by your markilux specialist.

- Replacement of the awning fabric
- Installation of a motor
- Retrofitting an automatic control system. In principle a motor drive must be available. Ask your specialist retailer about sun and wind sensors, remote control etc.

Retrofitting with different accessories, such as:

- markilux infra-red heater
- markilux revento (markilux 1600 / 1600 stretch, all without shadeplus/valance)
- markilux spotline
- markilux side screen (markilux 1600)
- markilux shadeplus / drop valance

Retrofitting of markilux awnings:

- Side Screen markilux 790

5. What you should also know

Due to the compact awning construction and depending on the width and the projection, contact between cover and folding arms may occur during extension and retraction. This has no detrimental effect on the functionality and / or durability of the awning.

6. Awning with shadeplus markilux 1600 / 1600 stretch

6.1 Manual operation shadeplus

1. Attach the crank-hook into the gear eyelet.
2. Hold the crank rod with one hand on the upper and one hand on the lower turning handle. During the operating procedure, pull the crank slightly towards the operator.
3. If the gear eyelet is on the left side:
 - Extension of the awning cover: Clockwise rotation of the crank.
 - Retraction of the awning cover: Counterclockwise rotation of the crank.
 - If the gear eyelet is on the right side, the directions of rotation are exactly the opposite.
4. If the crank is to remain in the gear eyelet, it must be protected against uncontrolled movements (e.g. when it is windy).
5. Direction of rotation during retraction shadeplus: If the winding direction is wrong, the shadeplus profile will not close flush with the projection profile.

Tip: If the shadeplus profile does not retract flush into the projection profile, extend the shadeplus cover completely and retract with the same rotary movement of the crank. Afterwards operate the crank in the opposite rotating direction when extending and retracting.

6.2 Motorised operation shadeplus

The instructions mentioned under point 3 are to be adhered to.

!Attention: The shadeplus-cover motor cannot be equipped with an automatic controller.

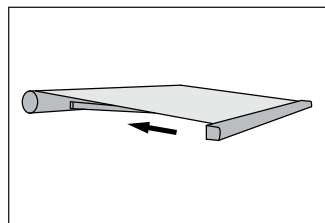
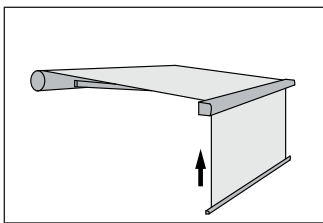

!Attention: Always retract the shadeplus cover first before retracting the entire awning. If the main motor of the awning is equipped with a controller, never leave your extended shadeplus cover unattended, because the awning could retract unintentionally!

When it is windy, please take particular care that the shadeplus cover with its valance profile does not carry out any uncontrolled movements. Retract your shadeplus cover immediately if it gets windy.

7. Safety note

Attention - risk of injury!

The folding arms of the markilux 1600 / 1600 stretch / 1650 generate very high compressive stress on the front profile and the fabric of the awning.

For the markilux 1600 / 1600 stretch / 1650 this compressive stress is generated by tension springs, which are within the folding arms.

For the markilux 1500, this compressive stress is generated by tension springs, which are located above the folding arm.

Because of the accident prevention regulations, these gas pistons must not be dismantled, opened (e.g. by drilling), forcibly damaged or heated over 80°C. The gas pistons contain oil and must be disposed of only through the raw materials trading sector or a hazardous waste collection site.

In case installation works to your awning are necessary, these have to be carried out only by a markilux expert!

8. Awning with lighting markilux 1650

8.1 Important advice

These instructions for use of markilux spotlights must be read and observed. Keep these instructions for future reference.

Attention - risk of injury!

The spotlights can heat up!

The lighting has to be switched off for some some minutes to cool down before you touch the individual spotlights.



Attention! You must never hang any objects or similar in front of the spotlights, and it should be ensured that there are no objects immediately underneath the projection profile both in retracted and in extended state. The spotlights may not be pointed directly at the awning cover. The lighting must always be switched off when the awning is closed.



Attention – risk of fatal injury! Do not grab or pull the mains leads, which are visible at every movement point of the folding arm! Do not suspend any objects from these mains leads!



 Check the awning regularly for signs of wear and tear at cables and lamps. If damages occur, an authorized markilux specialist is to be entrusted with the adjustment. The lighting system must be disconnected from the electricity supply during work on the system (unplug, switch off fuse). Switch on the illumination only when all cable connections have been established completely. Electrical installations or repairs are to be carried out in accordance with the installation regulations DIN VDE 0100 by a qualified electrician only. Awnings which need to be fixed must not be used. Only spare parts released by the markilux may be used.

Important advice!

Spare parts:

Either halogen or LED lamps are used for the lighting of your markilux 1650. You can replace a defective spotlight yourself. Never try to repair any other faults yourself! Always contact your specialised dealer.

- **LED spotlights have a very long service life. However, if a spotlight should be defective, you can purchase them through your markilux specialized agent.**

Automatic switch-off:

For safety reasons, the electronic transformer switches off automatically at a raised temperature, and switches on again after an appropriate cooling down period.

Moreover, an integrated timer switches the spotlights off automatically after a longer period of use: the spotlights switch off automatically after 6 hours for operation with io-homecontrol and after a period of 24 hours for wireless remote control with 433 MHz technology (RTS). The lighting can be reactivated by operating the AN button (double-clicking).

The **radiation intensity** of these LED lamps is harmless to people and underruns the RG 2 area acc. EN 62471. However, it is suggested not to look for a long time at the centre of the light source.

8.2 Spare part LED spot

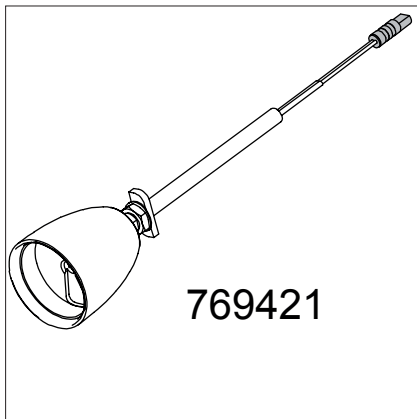

Technical specifications:

- Service life: approx. 20,000 hrs
- 5 W, 12 V
- Light colour 2700 Kelvin

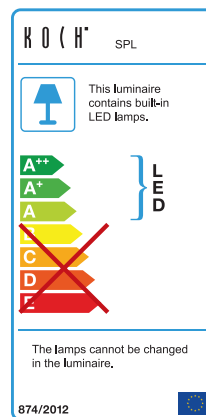

EU energy label according to EU directive 874/2012:

Energy efficiency A is very efficient. E is inefficient. The markilux LED spotlights are assigned to energy efficiency category A.

LED spotlights can be purchased from your markilux specialized agent under **order no. markilux 714701**.

8.3 Replacement of an LED spot

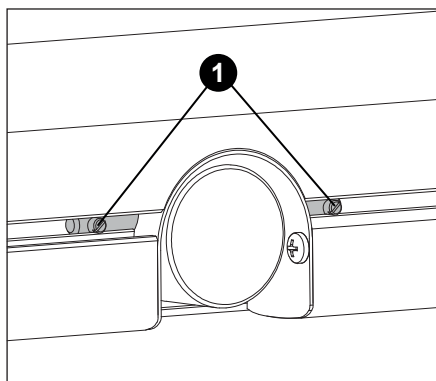

1. Loosen the lateral fixtures (1) of the respective LED spot.

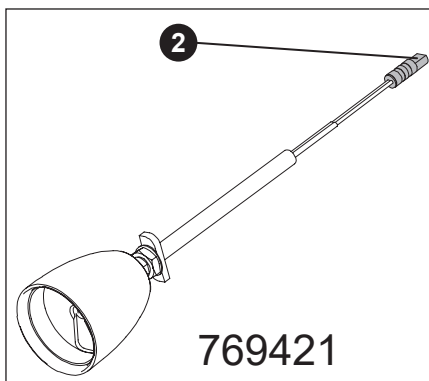

2. Disconnect the plug (2) of the defective spot light from the mains and plug in the new spot light.

Article no. new LED spot light with plug:
769421

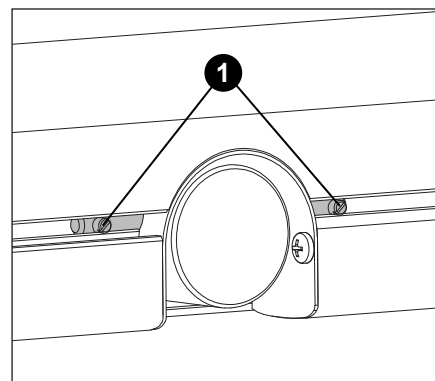

3. Should malfunctions still arise after replacement of the LED spotlight (1), please inform your markilux specialised agent.

8.4 Operation

Allow your markilux specialized agent to precisely explain operation of the markilux spotlights, because the awning and its functions have been individually manufactured for you.