

SANTA FE  
SHUTTERS



NEVADA & HAMPTON

SPECIFICATION V7



## FEATURES & BENEFITS

Created to the highest standard, Santa Fe Fauxwood shutters offer two ranges, Nevada & Hampton emulate the beauty of wood using HSPVC with a professionally applied paint finish. These meticulously crafted ranges are offered across our portfolio of shutter options: full-height, tier-on-tier, café style & track styles.

### NEVADA

Santa Fe's Nevada, Fauxwood shutters offer 3 louvre sizes: 63mm, 76mm and 89mm, they are the perfect solution for any room, especially areas of high moisture such as bathrooms and kitchens. The high quality PVC composition gives consumers the assurance that louvres and frames will not warp, discolour or crack with the addition of a 10-year warranty on whites and cream shutters, grey shutters offer a 5-year warranty. Santa Fe Nevada boasts a range of 9 colours.

### HAMPTON

Santa Fe Hampton Shutters presents a range of fauxwood shutters hand crafted in the UK.

Choose from 3 louvre sizes; 63mm, 76mm & 89mm, these offer the perfect solution for any room, especially with high moisture content such as bathrooms and kitchens. The high quality PVC composition gives consumers the assurance that louvres and frames will not warp, discolour or crack with the addition of a 10-year warranty.

Hampton and Nevada shutters comply with UK flame retardant standards.

	FULL HEIGHT	TIER ON TIER	CAFE	BAY
NEVADA	✓	✓	✓	✓
HAMPTON	✓	✓	✓	✓

	TRACK	SHAPED
NEVADA	✓	✓
HAMPTON	✗	✗

# SHUTTER STYLES

- **Full height**  
Designed to dress the full-height of the window. A functional, yet stylish feature for any home. Also available with a mid-rail, enabling the shutter louvres to be separated.
- **Café**  
Ideal for rooms where total privacy is not required. Café style shutters are fitted to the lower section of the window.  
*\* Please note that for Café style shutters, the top of the panels will be visible and unfinished. A 4-sided frame is selected for this reason.*
- **Tier-on-tier**  
One shutter with the panels separated at a horizontal position, each tier can be operated independently offering ultimate light control.
  - Tier on Tier shutters offer the optimal light and privacy control, however without the proper design tier on tier shutters will sag and perform improperly.

# SHUTTER TERMS

- **Bi-Fold**  
Shutter panels where two panels are hinged together in order to fold up together.
- **Café frame**  
A standard frame style where shutters cover the bottom half of the window and the top half are open. Café frames are available in 3-sided or 4-sided.
- **Mid Rail**  
A dividing rail that will take the place of louvres to add strength to the panel.
- **Tier on tier**  
Shutter configuration where two panels or groups of panels are mounted separately so they can be opened independently from each other.
- **Frames**  
Profiles used to frame the window opening, providing a mounting surface for the shutter panels. Frames can be mounted on the inside or outside of the window sill, depending on the frame style.
- **Inside mount**  
The frame is mounted or partially mounted inside the recessed portion of the window opening.
- **Louvre**  
A solid profile that rotates for light and privacy control. Louvres are available in 63mm, 76mm and 89mm widths.
- **Mouse hole**  
The rounded cut-out in the top shutter panel rail designed to fit the centre tilt rod. This hole allows complete closure of the louvres, providing a superior fit.
- **Outside mount**  
A mounting method where the frame is mounted to the wall or outside casing of the window opening.
- **Rails: Top & Bottom**  
The top and bottom horizontal framework of the shutter panel.

- A horizontal T-post will eradicate the light gap and facilitate easier installation.
- Tier on tier shutters must be designed so that the width of the panels are less than the height of the panels.
- Tier on tier shutters must have a four sided frame.
- There is a surcharge for tier on tier shutters.
- **Sliding Track (Nevada Only)**  
The perfect solution for large windows, patio doors and room dividers. Shutter panels glide effortlessly across a discreet track system facilitating smooth operation. Available as bypass or bi-fold.
- **Shaped Shutters (Nevada Only)**  
Santa Fe Shutters offers a wide range of shaped shutter options that can perfectly fit your window shape.
- **Reveal**  
The distance between the innermost edge of an outside mount frame and the outside edge of the window opening.
- **Stile**  
The vertical sides of the shutter panel.
- **Rabbet stile (Nevada Only)**  
The vertical sides of the panels have a channel & groove which interconnects to the opposing stile giving optimum light control.
- **Astragal stile**  
The vertical sides of the shutter panel designed to cover the light-gap where two panels meet. A small lip offers superior light control.
- **T-posts**  
Profiles used for extra support within a frame system. T-posts can be positioned vertically (or horizontally as part of a Tier on Tier shutter)
- **Tilt rod**  
Supplied as standard in the centre of the panel. Tilt rods are used to open and close the louvres for light and privacy control.
- **Clearview Tilt rod**  
Metal tilt rod secured to the back (hinge-side) of the panel giving an unobstructed view from the front of the panel.
- **Rack and Pinion (RPS)**  
A concealed tilt mechanism within the stile of the shutter.
- **Light Control and Privacy**  
The privacy and light control from your shutter will depend on the size of louvre. Larger louvres will allow for more light, while smaller louvres will provide more privacy. Shutters are a light diffusing product rather than blackout, due to their design light will enter the room where the louvre meets the edge of the frame. To ensure complete blackout, we recommend the installation of a blackout roller or cellular blind in the recess.
- **Panels & Shutters**  
A panel sits inside the frame of the shutter and consist of the louvres, stiles and top/bottom rails. While a shutter is the combination of panel and frame.

# SHUTTER SPECIFICATION

	NEVADA	HAMPTON
Composition	HSPVC	HSPVC
Weight (m3)	600kg/m3	600kg/m3
Colour Option	9 Colours (Vivid white, Bright white, Silk white, White, Ecru, Phantom, Moonlit, Lunar & Armory)	Standard: 2 colours (Vivid white & Silk white)
Full Height	Yes	Yes
Tier on Tier	Yes	Yes
Café Style	Yes	Yes
Track Options	Yes	No
Special Shapes	Yes	No
Stile Profile	Butt, Rabbet and Astragal	Butt and Astragal
Louvre Width	63mm, 76mm, 89mm Elliptical, 89mm Urban	63mm, 76mm, 89mm Elliptical, 89mm Urban
Stile Size	27mm Thick x 51mm Width	27mm Thick x 51mm Width
Mid Rail	1700mm (over 2400mm 2 mid rails required) (Panels over 1524mm high & 609mm wide require at least 1 mid rail)	1700mm (Panels over 1524mm high & 609mm wide require at least 1 mid rail)
Mid Rail Widths	61mm	61mm
Rail Thickness	21mm	21mm
Minimum Panel Height	410mm	410mm
Maximum Panel Height	3000mm	2450mm
Tilt Rod	Centre, Clearview, Offset, RPS	Centre, Clearview, RPS
Minimum Panel Width	232mm	210mm
Maximum Single Panel Width	914mm (RPS: 600mm)	800mm
Maximum Panel Width (Bi-Fold & Bi-Pass)	Bi-Fold: 600mm, Bi-Pass: 914mm	Bi-Fold: 600mm

Nevada shutters over 1829mm high and panels that are hinged together will be aluminium reinforced

	SHUTTER REFERENCE				
	Min Width	Max Width without T-post	Max Width with T-post	Min Height	Max Height
Full Height without mid-rail	266	2463	3500	466	1756
Full Height with Mid-rail	266	2463	3500	775	2506
Cafe	266	2463	3500	466	2506 (With Mid-Rail)
Tier on Tier	266	2463	N/A	906	3000

Manufacturing Tolerance: +1mm/-2mm. Frame outside tolerance (for fitting) +1mm/-3mm

Please note: For Hampton shutters maximum width for all Z frames is 3380mm

# OUR SHUTTER

## FRONT VIEW OF LOUVRE SIZES

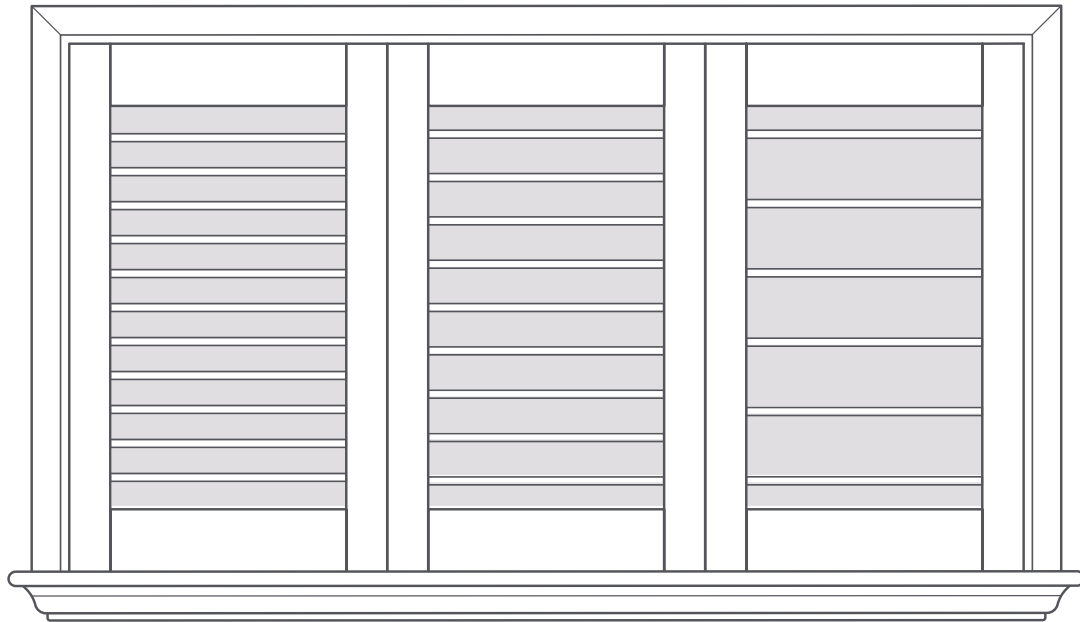

63MM

76MM

89MM

ILLUSTRATION SHOWS LOUVRES IN THE OPEN POSITION

### AVAILABLE FITTING OPTIONS

- No Frame/ Panel only  
Hinges only
- L Frames
- Z Frames (Inside Mount Only)
- Deco Frame (Outside Mount Only)

### AVAILABLE LOUVRE SIZES

- 63mm - Elliptical only
- 76mm - Elliptical only
- 89mm - Elliptical and Urban

### MID RAIL

- 61mm

### TILT OPEN

- Centre
- Clearview
- RPS

The movement of the louvres can be easily tightened/loosened by adjusting the tensioning screw positioned either side of the panel.

# HAMPTON & NEVADA WARRANTY

## WHAT IS COVERED IN THE WARRANTY

- Decora Blind Systems warrants to the original purchaser that each custom shutter product, properly installed and maintained in the window or door opening for which it was made, will be free from defects in materials and workmanship.
- There is a 10-year warranty on our Hampton shutters and Nevada white and cream shutters. We offer a 5-year warranty on Nevada grey shutters.
- Any claims for incorrect or defective products must be brought to our attention within 5 days of receipt, and before shutters are altered in any manner or installation is attempted.
- If the product is found to be defective in material or workmanship under normal use, or products that do not meet our quality standards, Decora Blind Systems will, at its discretion, repair or replace any defective parts or components without charge, provided that the original purchaser ships the product to the designated repair facility.
- This warranty does not imply automatic replacement of any product from Decora Blind Systems.

## WHAT IS NOT COVERED IN THE WARRANTY

- This warranty does not cover conditions or damages resulting from accidents, alterations, misuse, abuse, misapplication, fire, flood, or other natural disasters, failure to follow use, care of installation and maintenance instructions, settlement of structural defects of the building or shutters that have ordered outside recommended specification.
- Shutters are light controlling but not block out. Varying levels of light filtration between louvres, frames and panels may occur.
- Installing at location that will result in continued heat exposure over high degrees that cause warpage and shrinkage of the shutters.
- Decora Blind Systems will not be liable for any incurred costs, such as travel costs and time, nor for damages or loss to other property

## SANTA FE SHUTTER IMPERFECTIONS

- Santa Fe Shutters are manufactured to industry standards. Minor imperfections or blemishes not visible at an 90 degree angle from 1.5m back under natural lighting conditions are not considered defects.
- Nevada and Hampton will only be considered for repair if there are any marks or any discolouration visible from 1.5m back.
- Nevada shutters are supplied with touch-up paint kits.
- Colour matched screw cover stickers/caps are only available on Hampton Vivid, Silk and Nevada Vivid, Silk & Bright White shutters.
- Additional touch-up kits are available upon request.
- When opened, the panels (especially when two or more are hinged together) are likely to dip slightly when the panel is opened. This requires the user to slightly lift the panel when closing.

## HAMPTON & NEVADA ENERGY SAVING DATA

- Hampton and Nevada shutters have been tested for their thermal conduction properties in line with ASTM C518 - 2004 to determine the thermal transmission properties, by means of heat flow.
- Test results of 0.10035 certify minimal heat flow is conducted through the shutter, enhancing heat control within a room.

# HAMPTON & NEVADA WARRANTY

## CANCELLATION AND MODIFICATION

The prompt production of any order requires a strict manufacturing scheduling. Therefore, once an order has been submitted cancellations will not be accepted and the company who placed the order will be liable for the full cost of the order. Changes will be allowed only if the order has not gone into production (this usually occurs within 48 hours of submitting an order). Any costs and/or expenses resulting from a cancellation or change will be charged to the company who placed the order.

## REPLACEMENT OF PARTS OR REPAIRS

The factory reserve the right to change the design or discontinue any components. If an exact replacement part is not available, then the factory reserve the right to substitute a part or parts of equal quality at its sole discretion.

## MAINTENANCE AND CLEANING

To clean your Santa Fe Shutters we advise the following:

Dust - Dry Cloth or vacuum using the soft brush attachment for your vacuum cleaner.

Dirty Marks - Use a damp cloth/wet wipe - we do not recommend the use of abrasive cleaning products on shutters.



# SHUTTER COMPONENTS

\* All measurements in mm

## LOUVRES

63mm



76mm



89mm



Urban Louvre

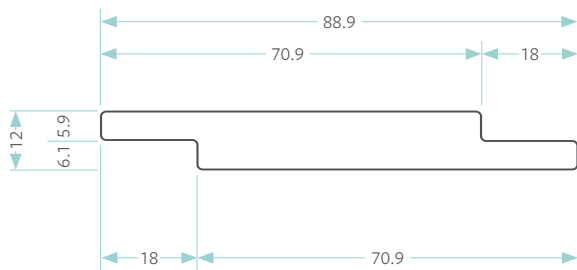

## ALUMINIUM REINFORCED LOUVRE - NEVADA ONLY

Elliptical Louvre



Urban Louvre



## LOUVRE SPACING

Recommended hole pitch size

Louvre Size	Louvre Type	Pitch
63mm	Elliptical	50.8mm
76mm	Elliptical	63.5mm
89mm	Elliptical / Urban	76.2mm

# STILE TYPES

\* All measurements in mm

## BEADED

### BUTT STILE

50.8mm

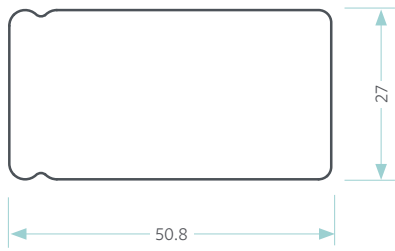

### REINFORCED BUTT STILE - NEVADA ONLY

50.8mm

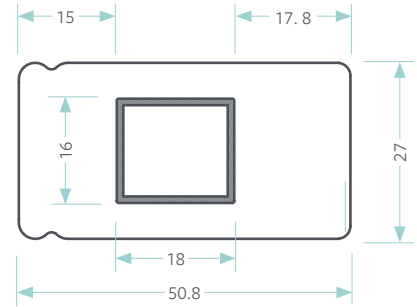

### RABBET STILE - NEVADA ONLY

53.5mm

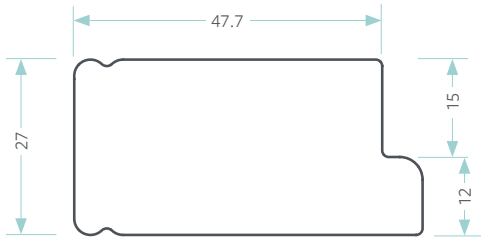

### REINFORCED RABBET STILE - NEVADA ONLY

53.5mm

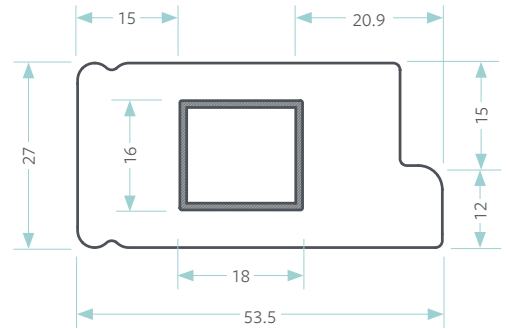

### ASTRAGAL STILE

50.8mm

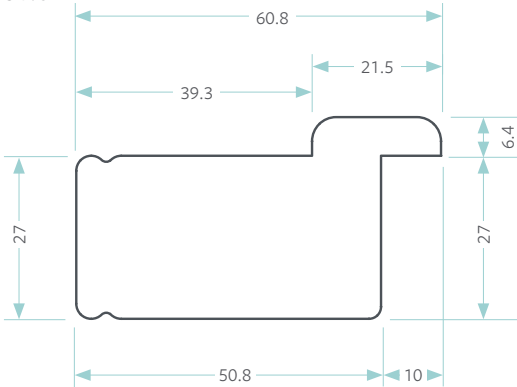

### REINFORCED ASTRAGAL STILE - NEVADA ONLY

50.8mm

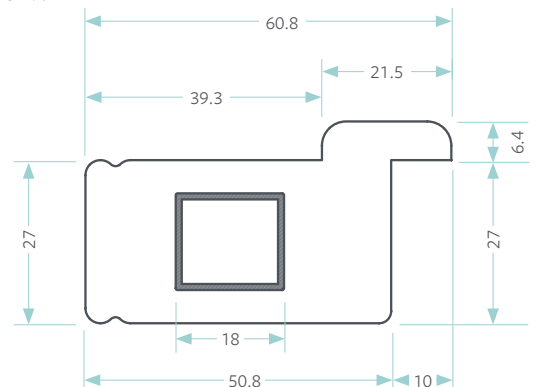

# STILE TYPES

## FLAT

### FLAT BUTT STILE

50.8mm

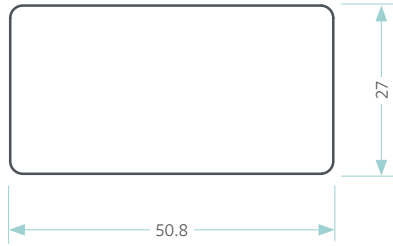

### REINFORCED FLAT BUTT STILE - NEVADA ONLY

50.8mm

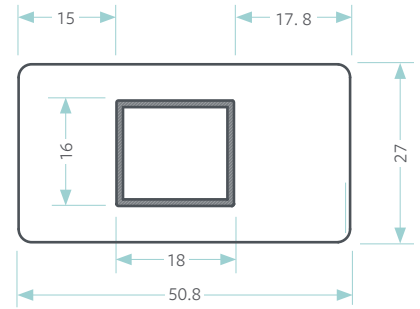

### FLAT RABBET STILE - NEVADA ONLY

53.5mm

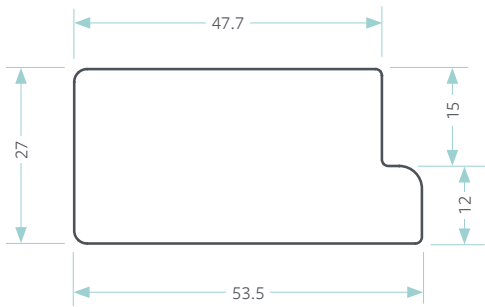

### REINFORCED FLAT RABBET STILE - NEVADA ONLY

53.5mm

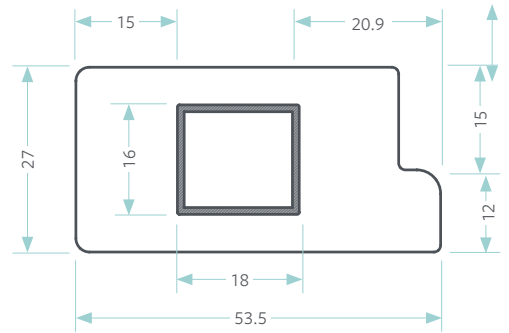

### FLAT ASTRAGAL STILE

50.8mm

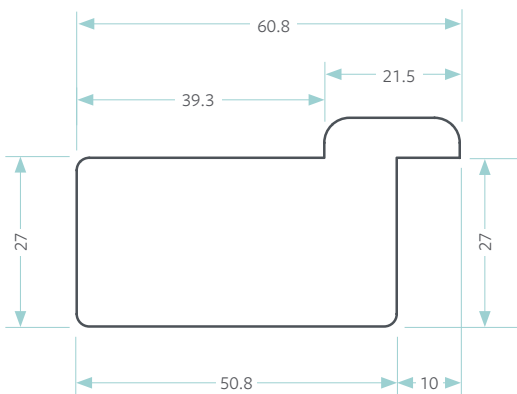

### REINFORCED FLAT ASTRAGAL STILE - NEVADA ONLY

50.8mm

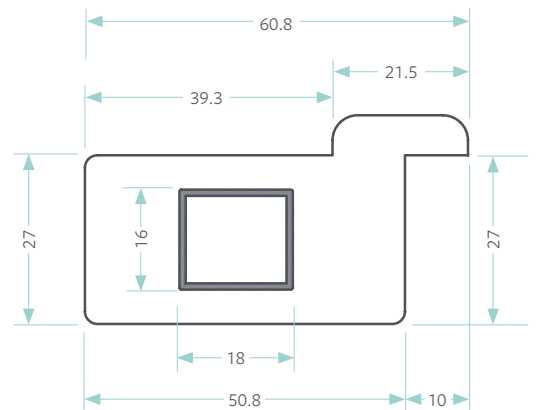

# SHUTTER RAILS

\* All measurements in mm

## TOP/ BOTTOM RAIL FOR ELLIPTICAL LOUVRE

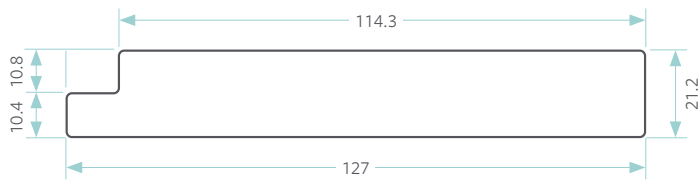

## TOP/ BOTTOM RAIL FOR URBAN LOUVRE

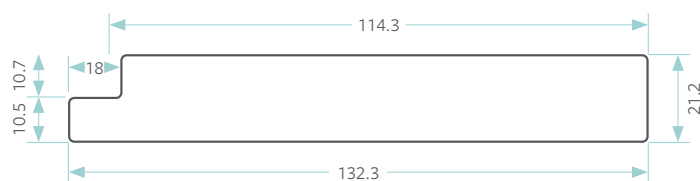

## MID-RAIL FOR ELLIPTICAL LOUVRE

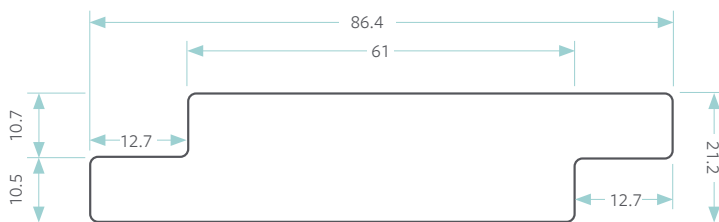

## MID-RAIL FOR URBAN LOUVRE

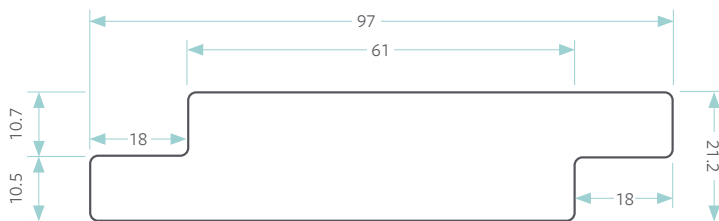

## MID-RAIL (61MM)

To specify its position, measure from the bottom of the shutter to the centre point of where the mid rail is required.

Mid rail required over 1700mm, or if panel is over 609mm wide the required height is 1524mm.

Top and bottom rails are the same size, please note placement of the rail may vary from requested, please see table below:

Louvre Size	Mid-Rail Tolerance
63mm	+/- 25.4mm
76mm	+/- 31.7mm
89mm	+/- 38.1mm

## NEVADA ONLY

On the Nevada range only, exact position can be requested. Measurement **MUST** be taken from the bottom of the opening to the centre of the object to be covered.

If exact position is selected and pushes out of specification, the Santa Fe team will contact for approval before shutter is manufactured.

## TILT RODS- CENTRE TILT

Tilt rods are used to open and close the louvres, simply by moving up and down. The tilt rod is attached to the louvres by stainless steel staples. Tilt rods are supplied as standard in the centre of the panel. *Not available with Urban louvres.*

Offset tilt rods on Nevada shutters will be positioned 25mm from the edge of the louvre on the hinge side of the panel as standard.

### TILT ROD

(Hampton & Nevada)

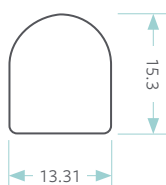

## TILT RODS-CLEARVIEW

With this option, a metal tilt rod is placed on the back of the panel, screwed to the side of the louvres on the same side as the hinges. No tilt rod is visible from the front of the panel on the Clearview option. Moving the louvres by hand operates all the louvres.

For Nevada shutters the metal tilt rod is white for the painted finishes, and stainless steel on all stained colours.

For Hampton shutters the metal tilt rod is white.

The maximum louvre quantity attached to a Clearview (hidden) tilt rod will be as per the following table, and if the louvre quantity exceeds this limit the hidden tilt rod will be split automatically into two pieces. (The approximate panel height is 1200mm.) In case of an odd number, the top section will be the larger. This also applies to a panel with mid-rails.

### SPLIT TILT ROD

When split tilt rod position is specified, it will be measured from the bottom of the shutter to the nearest pitch. The group of louvres above and below this point will operate independently of one another

### TILT RODS-RPS

With this option, the metal rack and nylon pinion is concealed within the stile of the shutter. This removes the need for external tilt rods and enhances the visibility through the shutter. Moving the louvres by hand, operates all of the louvres.

The maximum louvre quantity attached to the RPS will be as per the table above, and if the louvre quantity exceeds this limit, the system will be split automatically into two equal sized mechanisms. In the case of an odd number, the top mechanism will be larger. This is also applies to panels with midrails.



Louvre Size	Maximum Number of Louvres per Clearview Tilt Rod	RPS
63mm	21	21
76mm	17	17
89mm	14	14

# L FRAMES

\* All measurements in mm

Suitable for shutters installed on or close to edge of window recess.

We recommend a frame with cover is selected as they incorporate a cover strip that will hide all installation screw heads. Any other frame choice will be installed with screw heads visible.

L FRAME WITH COVER

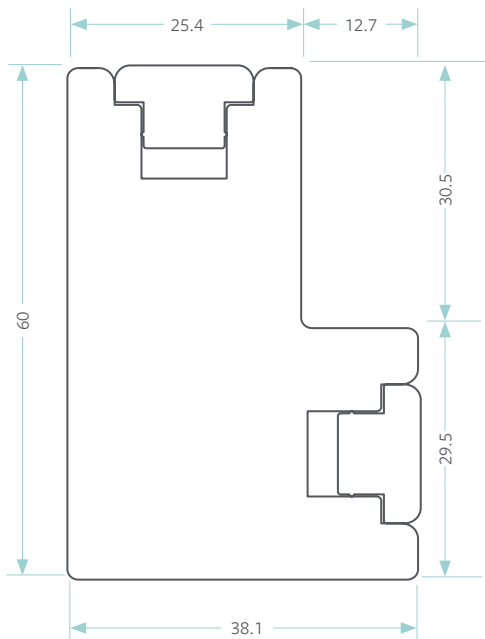

FLAT L FRAME WITH COVER

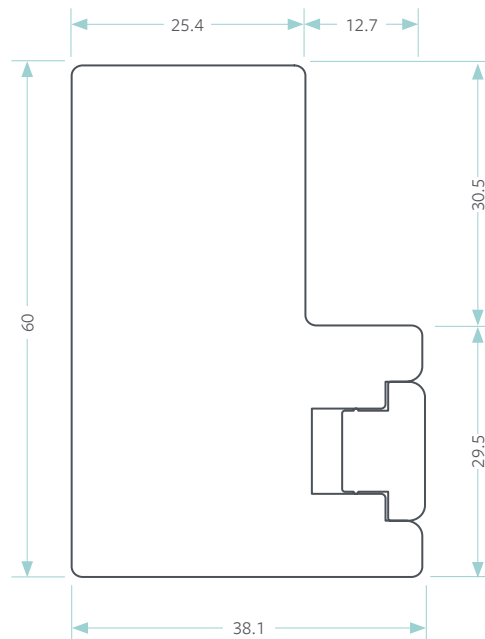

FLAT L FRAME

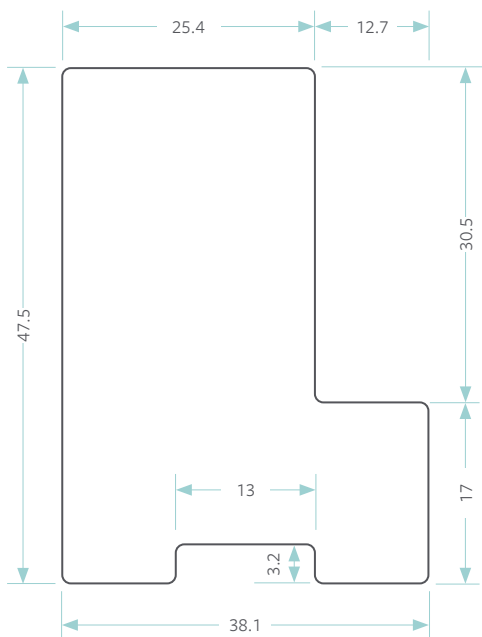

90MM L FRAME - HAMPTON ONLY

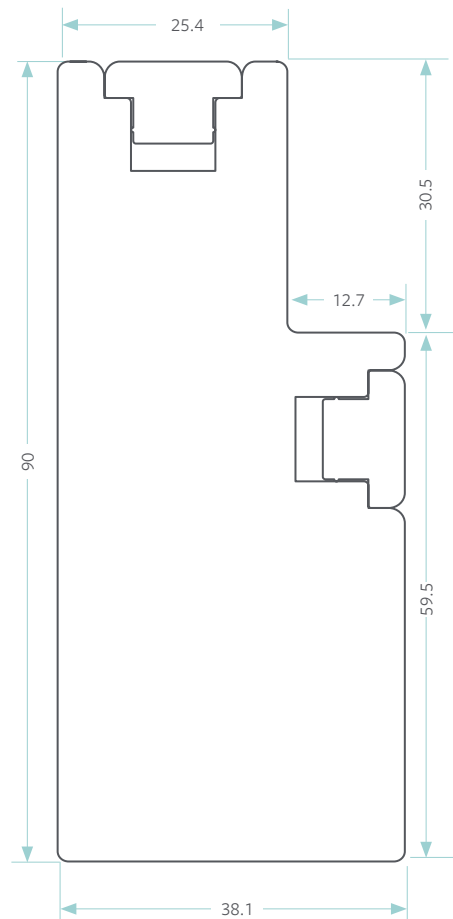

# Z FRAMES

\* All measurements in mm

Suitable for shutters installed to outer edge of a window recess.

## ELEGANT Z FRAME

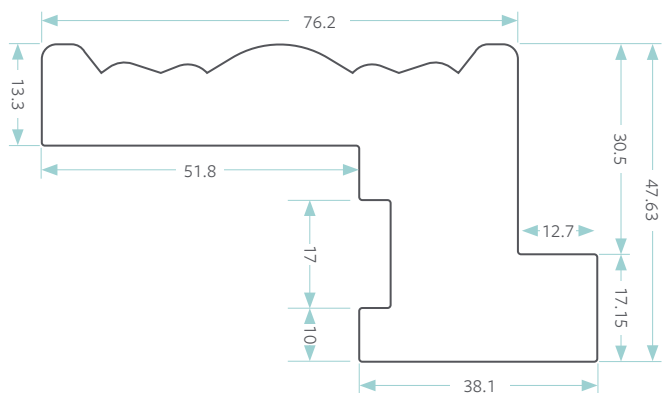

## DELUXE Z FRAME

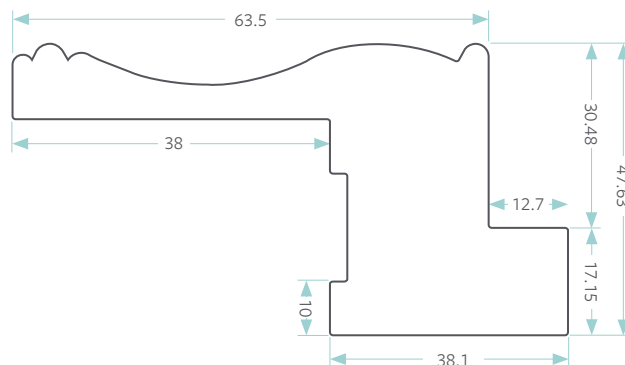

## FLAT EDGE Z FRAME WITH COVER

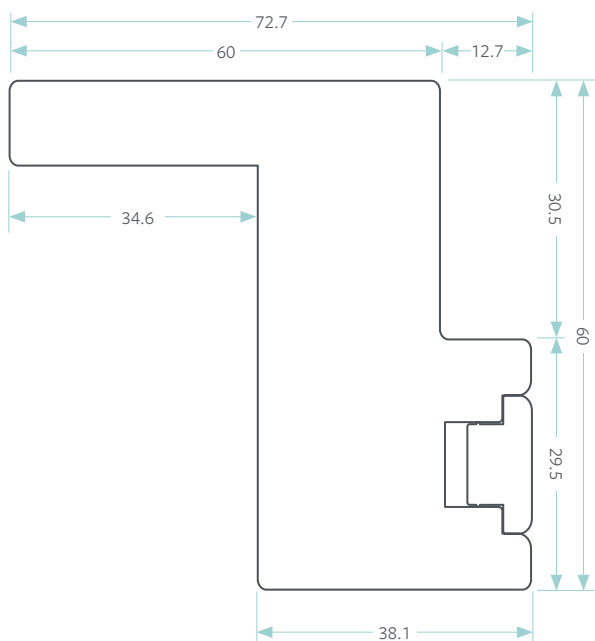

## Z FRAME WITH COVER

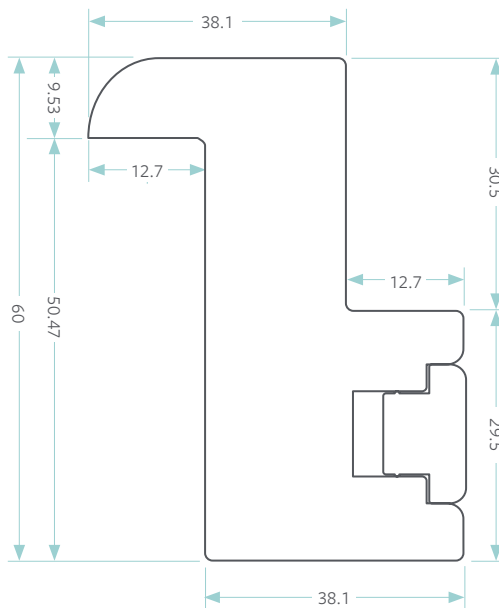

## FLAT Z FRAME

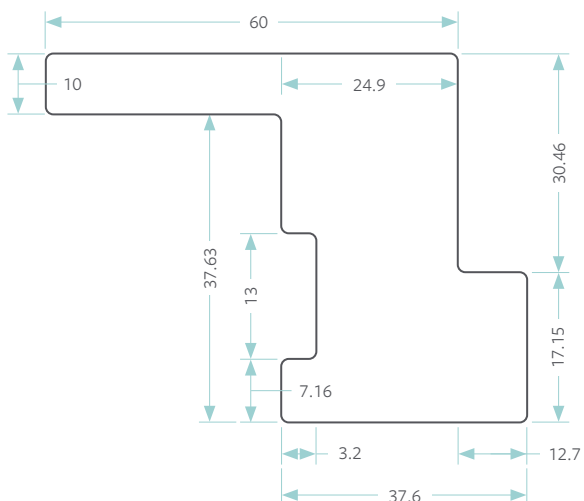

# DECO FRAME

\* All measurements in mm

Suitable for shutters fitted to the wall

## SPECIAL RAIL - DECO FRAME

69.85mm - Used for shutters installed outside the recess.

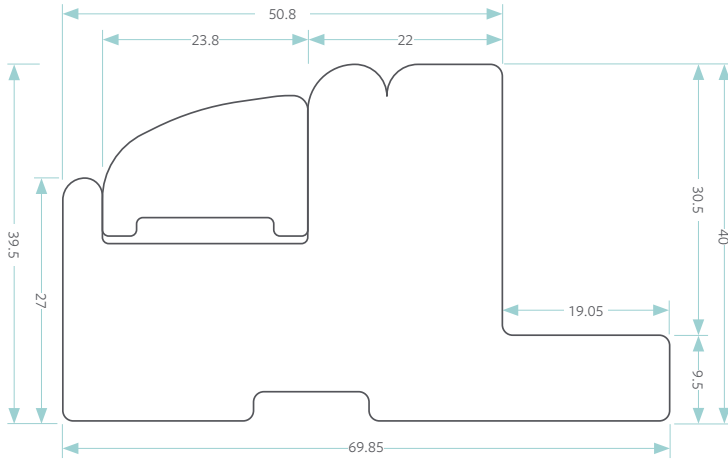

\*Please note: T Post not applicable with Deco Frame

## HOFFMAN KEYS

All frame mitres will be supplied pre-cut with a slot to accept a plastic Hoffman key. The Hoffman key will be attached to the end of the frame. This will allow for easy assembly of the frame prior to installation and will hold the mitre together.

## HINGES

Stainless Steel hinges and screws are 316-grade material; all other hinges and screws are mild steel with either a paint finish or electroplated finish. The quantity of hinges supplied will depend on the height of the shutter panel.

## BATTENS

Battens are available to order.

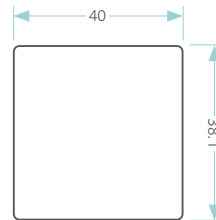

Batten

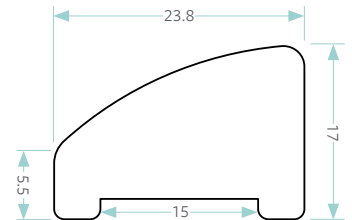

Deco Batten

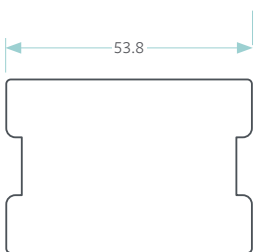

Build Out Block

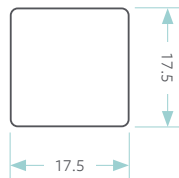

Light Block

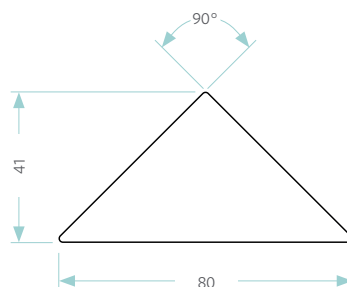

Triangle batten for 90° Corner

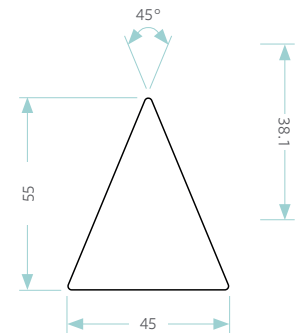

Triangle Batten for 135° Bay

## TRIMS



20mm



35mm

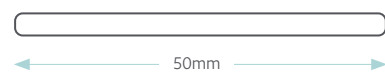

50mm

# SHUTTER FRAMES

\* All measurements in mm

## 25MM BEADED T-POST

25.40mm (Hampton & Nevada)

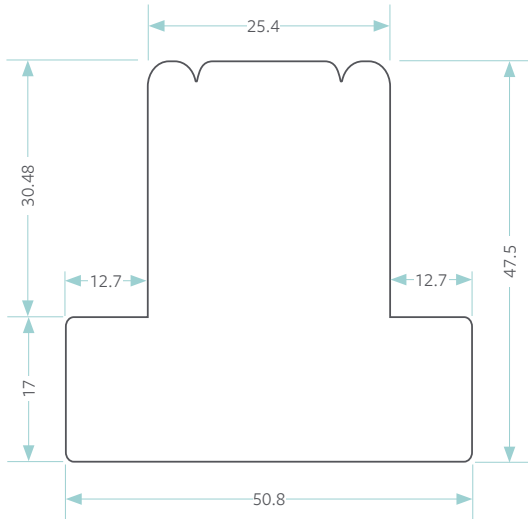

## 50MM BEADED T-POST

50.8mm (Nevada)

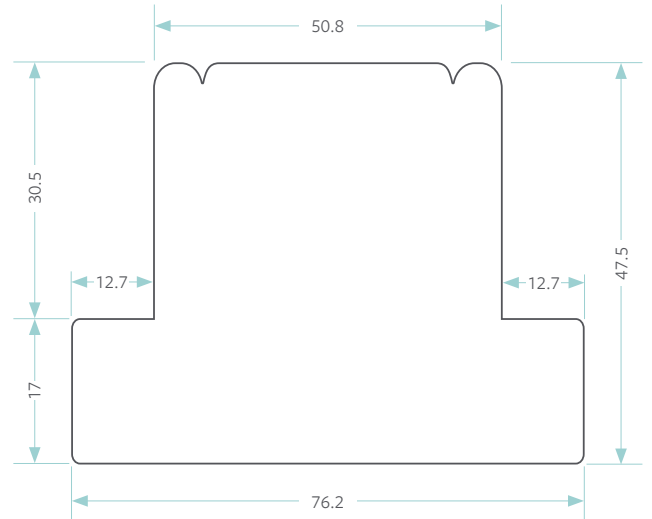

## 25MM FLAT T-POST

25.40mm (Hampton & Nevada)

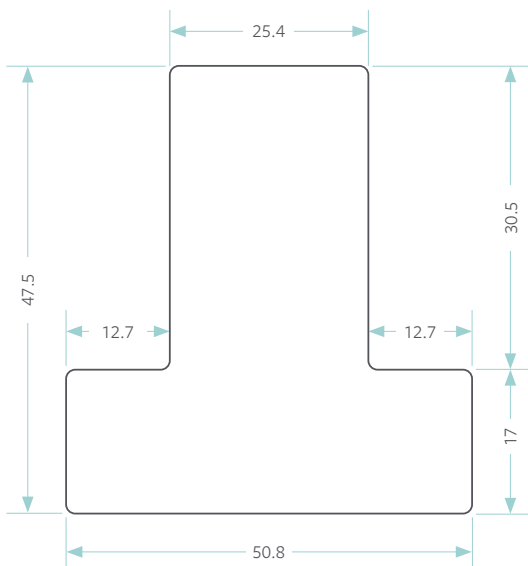

## T-POST LOCATION

T-Post location is measured from the outer edge of the left frame to the centre of the T-Post.

Please note: Tier on tier with a Horizontal T-Post on a 3 sided frame with no bottom is not available to order on Hampton shutters.

# SHUTTER BAY POSTS

\* All measurements in mm

## 90° CL10 BAY POST

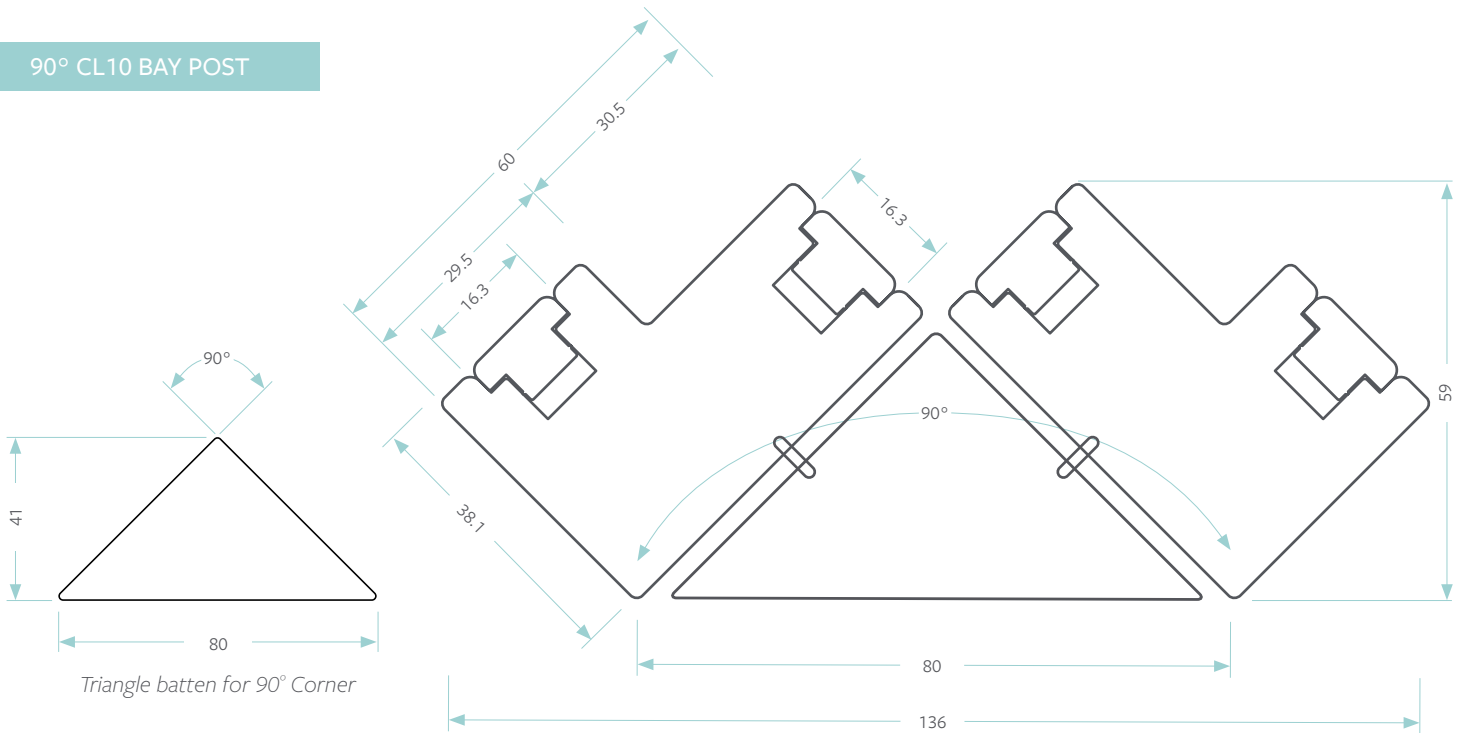

## 135° CL10 BAY POST

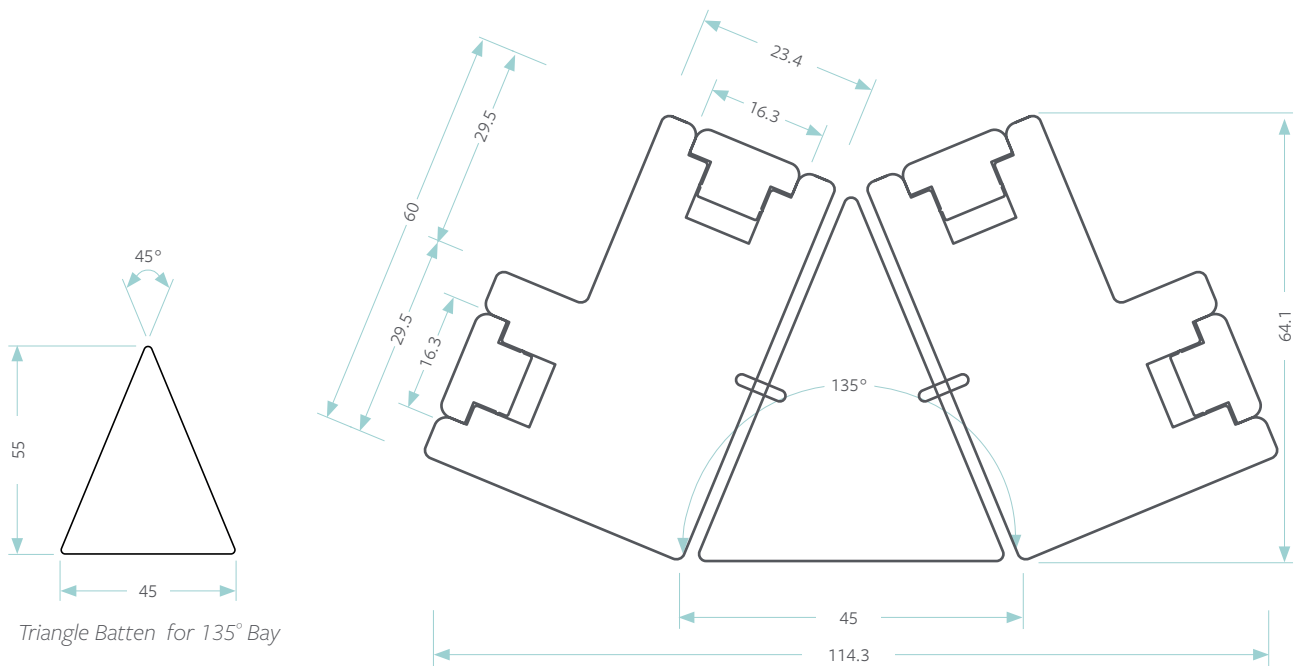

\*Please specify on the order form which to supply, the 90° Bay Post or the 135° Bay Post.

### Nevada Only

\*Bespoke Angle Bay Posts are available, please specify the required angle on the order form.

\*Custom made angles available.

## MAGNET & STRIKING PLATE

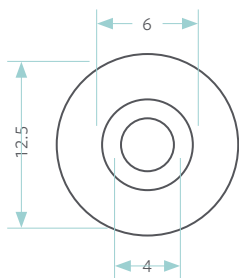

Magnet

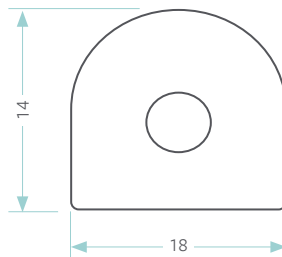

Striking Plate

\*Magnets are attached to the shutter panel. Striking plates are attached to the frame. The magnet will be installed at the corner of the stile, with its centre 10mm away from the edge of the stile. Striking plates are white powder coated.

Standard and Offset hinges are available.

### STANDARD HINGE

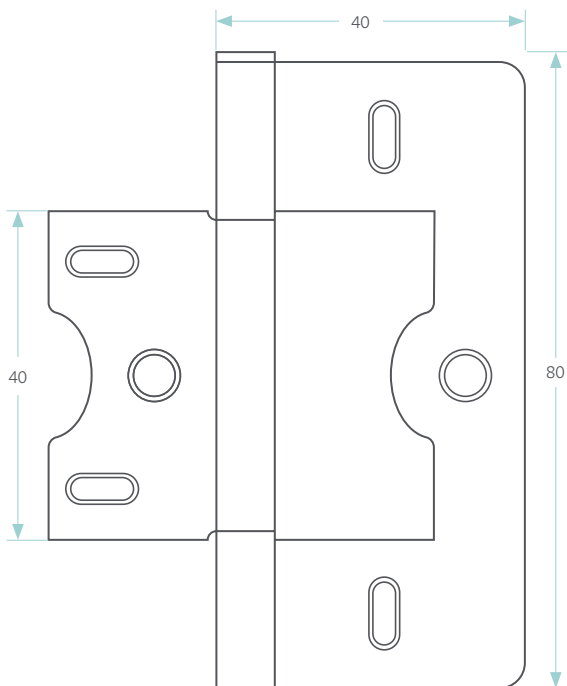

### OFFSET HINGE

(Nevada Only)

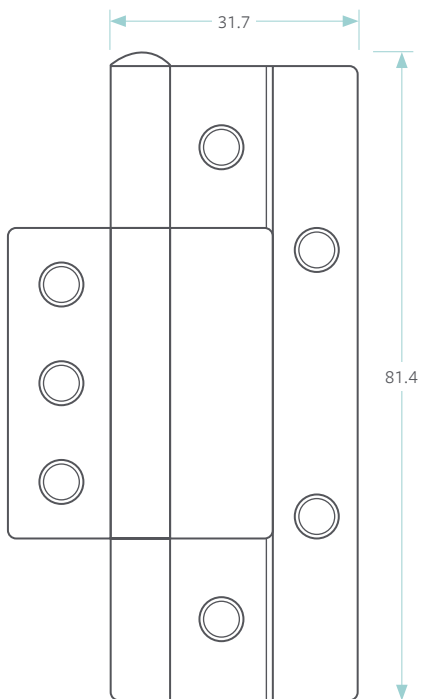

# HARDWARE

## HINGES COME IN 7 COLOURS

### NEVADA - DEFAULT HINGE COLOURS

COLOUR	DEFAULT HINGE COLOUR	OTHER OPTIONS
Vivid White	White	Stainless Steel
Bright White	White	Stainless Steel
Silk White	Pearl	Stainless Steel
White	White	Stainless Steel
Ecu	Pearl	Stainless Steel
Phantom	Phantom	Stainless Steel
Moonlit	Moonlit	Stainless Steel
Lunar	Lunar	Stainless Steel
Armory	Armory	Stainless Steel

### HAMPTON - DEFAULT HINGE COLOURS

COLOUR	DEFAULT HINGE COLOUR	OTHER OPTIONS
Vivid White	White	Stainless Steel
Silk White	Pearl	Stainless Steel

### HINGE MINIMUM REQUIREMENTS

PANEL HEIGHT	HINGE QUANTITY
Up to 1117mm	2
1118mm to 1829mm	3
1830mm to 2438mm	4
Over 2438mm	5

# STYLE PORTFOLIO (NEVADA ONLY)

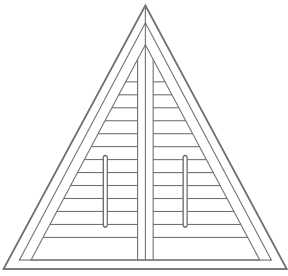

Triangle

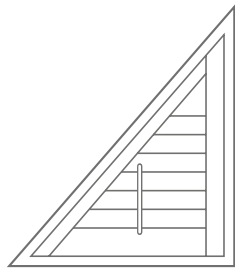

Triangle Right

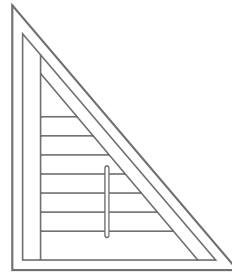

Triangle Left

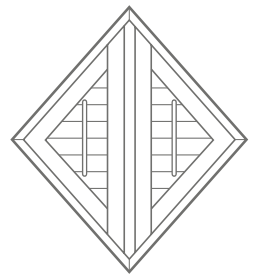

Diamond with Vertical T-Post

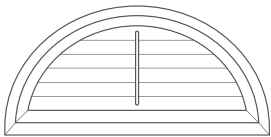

Sunburst

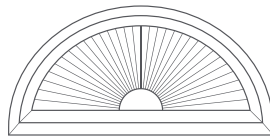

Sunburst Fan

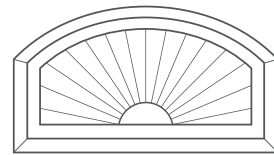

Elongated Sunburst

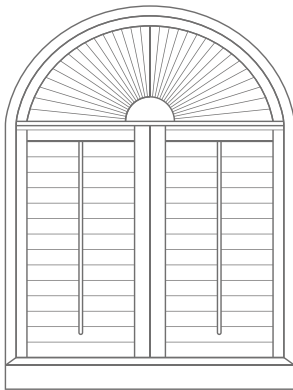

Sunburst Fan with Horizontal T-post

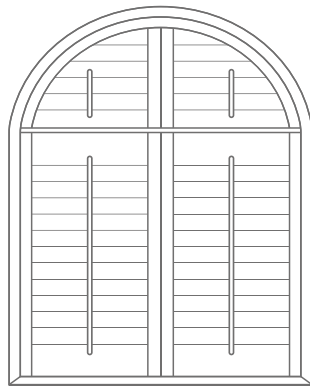

Sunburst with Horizontal T-Post

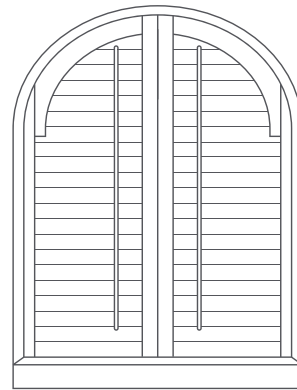

Arch

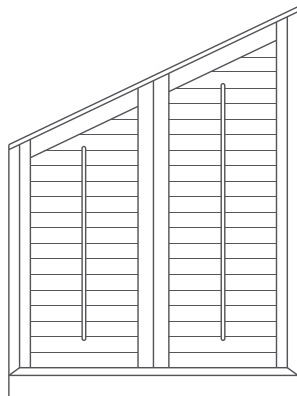

Left Rake

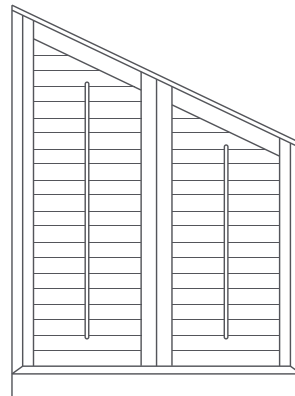

Right Rake

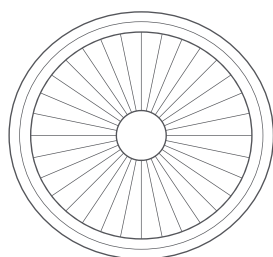

Porthole Fan

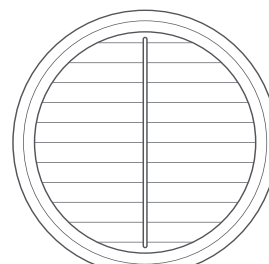

Porthole

# STYLE PORTFOLIO (NEVADA ONLY)

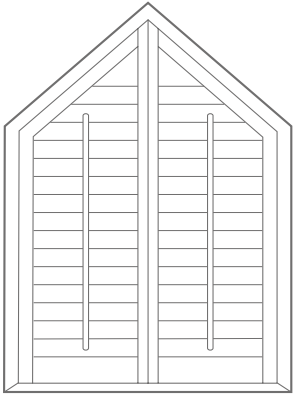

Apex

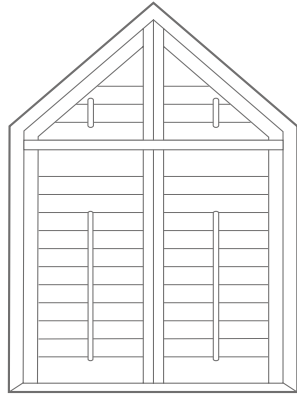

Apex with Horizontal T-Post

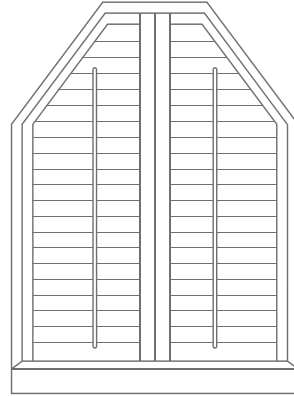

Apex Flat Top

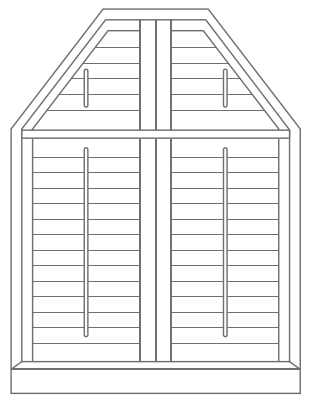

Apex Flat Top with Horizontal T-Post

Please note: For all porthole, sunburst and arch shaped shutters Flat L Frame will be used as default.

Shape	Frame	Minimum Daimeter
Round or Curve	Flat L Frame	500mm
	Flat L Frame with Cover	700mml
	L Frame with Cover	Not Available
	Z Frame with Cover	700mm
	Flat Z Frame	700mm
	Flat Z Frame with Cover	700mm
	Embassy Z Frame	700mm
	Regal Z Frame	700mm
	Deco Frame	Not Available



# BI-FOLD TRACKING SHUTTER

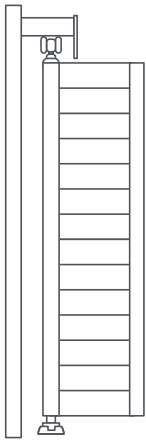

Bi-Fold Tracked Shutter is shutter panel where two or more panels are hinged together so they can be folded and slide to one side.

To avoid unforeseen problems, it is very important to provide the nett measurement of height and width of the window opening.

In the charts below, you will see how to measure the nett height and width for Bi-Fold Tracked Shutter.

## NETT HEIGHT MEASUREMENT

The raised bottom track sits directly on the floor without bottom board.  
The bottom clearance will be 16mm between the panel's bottom and the floor.

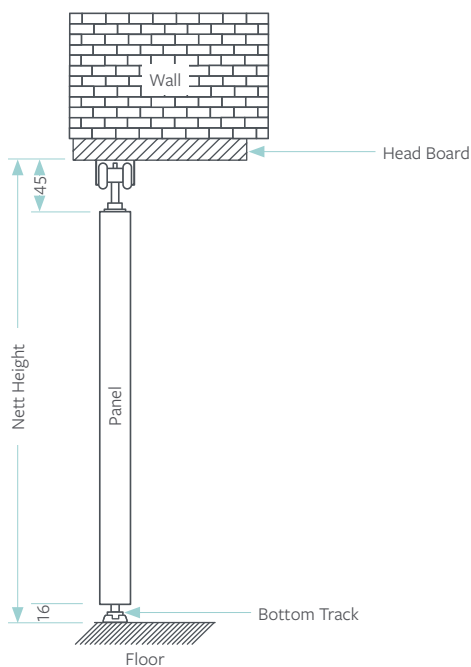

Inside Mount

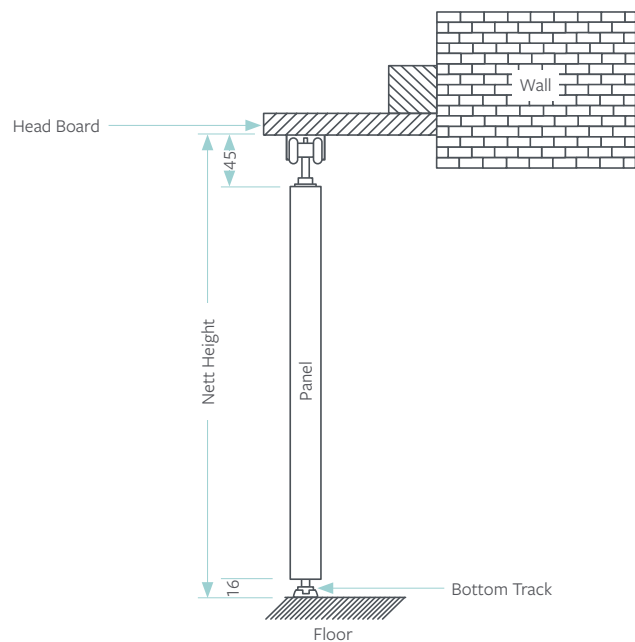

Outside Mount

*\*The thickness of the head board is 21mm.  
The thickness of the bottom board is 21mm.*

# BI-FOLD TRACKING SHUTTER

## RAISED BOTTOM TRACK WITH BOTTOM BOARD

The raised bottom track sits directly on the bottom board.  
The bottom clearance will be 35mm between the panel's bottom and the floor.

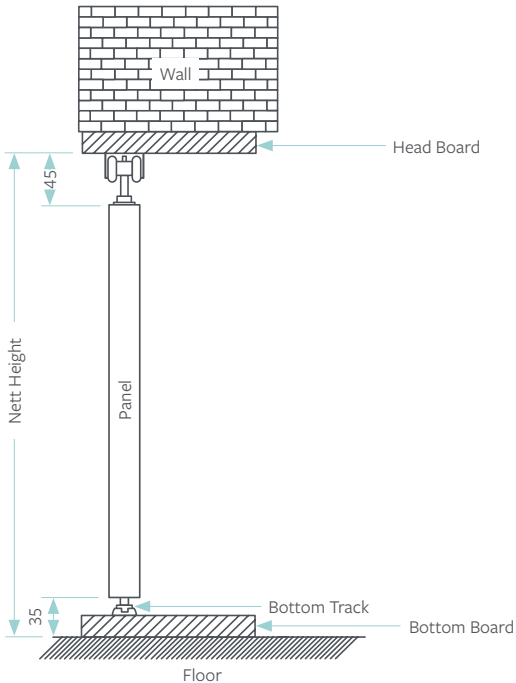

Inside Mount

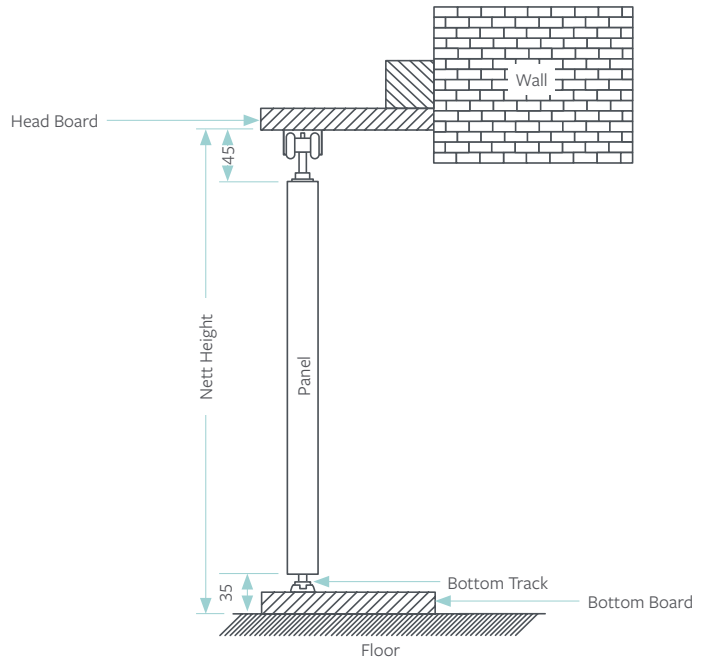

Outside Mount

## RECESSED BOTTOM TRACK WITH BOTTOM BOARD

The Bottom Track is recessed fully into bottom board.  
The bottom clearance is 27mm between the panel's bottom and the floor.

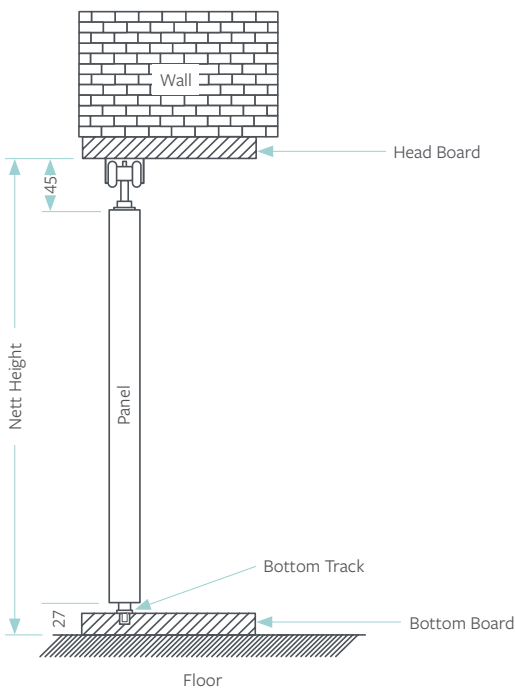

Inside Mount

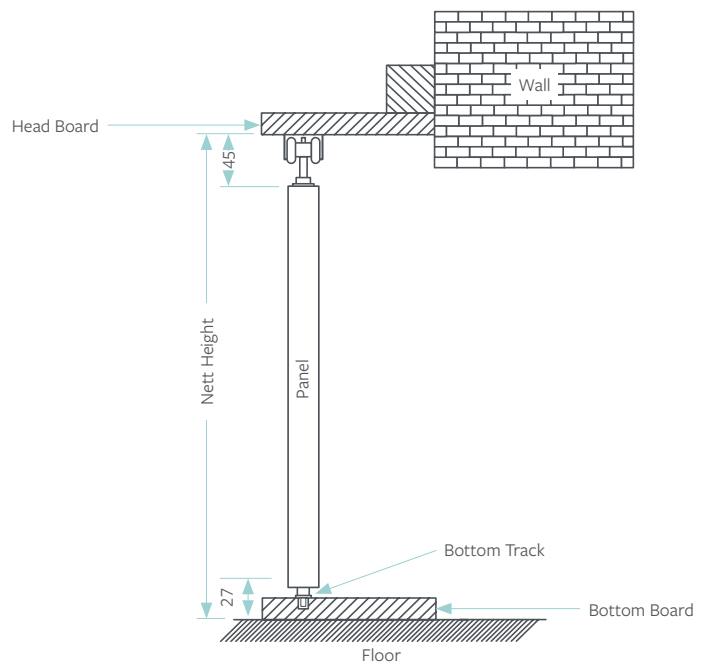

Outside Mount

# BI-FOLD TRACKING SHUTTER

## TOP TRACK POSITION

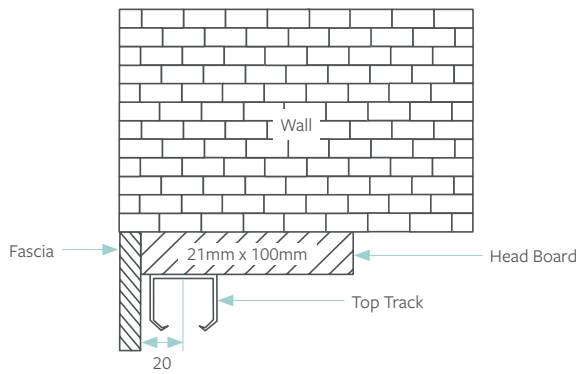

Inside Mount

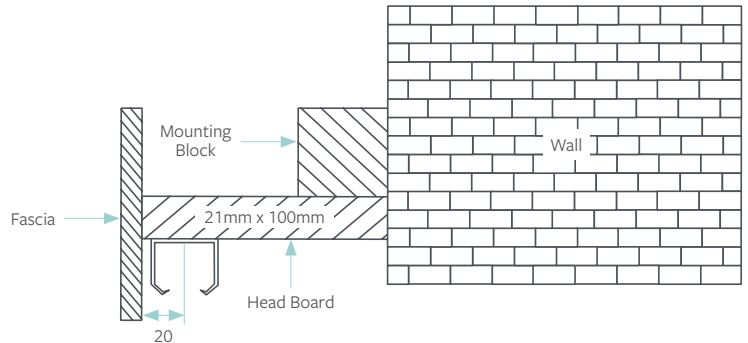

Outside Mount

## BOTTOM TRACK POSITION

Raised Bottom Track sits at 20mm from the edge of the bottom board to the centre of it.

If there's no bottom board, then the bottom track will have to be aligned with the top track manually.

We will pre-attach double adhesive tape (1.5mm thick) onto the Raised Bottom Track. Screws will be supplied as well to strengthen the installation.

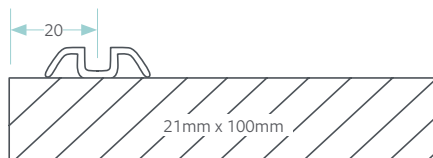

Recessed Bottom Track is recessed fully into the bottom board at 20mm from the edge of the bottom board to the centre of it.

If there's no bottom board, then the bottom track needs to be aligned with the top track and recessed into the floor manually.

For Recessed Bottom Track, we will supply screws as we don't recommend double adhesive tape.

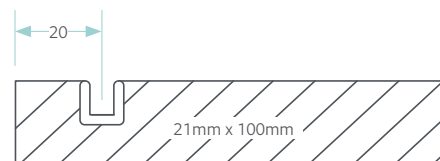

Both Raised and Recessed Bottom Tracks will be supplied in the same length as the bottom board, or same as the header if the bottom board is not used.

Both Raised and Recessed Bottom Track will be supplied loose.

## HEADER & SIDE FRAME

For Header length more than 3657mm. We'll use 2 pieces of the same length components to join together with mitre and dowel.

The top track will be pre-assembled onto the header.

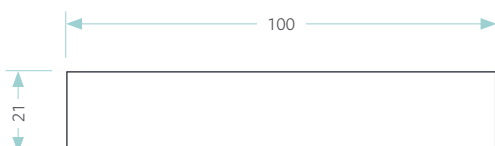

# BI-FOLD TRACKING SHUTTER

## MOUNTING BLOCK/SUPPORTING STRIP

17.46mm x 17.46mm for side frame.  
38.1mm x 40mm for header.

We will supply the mounting block for both inside and outside mount in the same length with header and side frame

## SIDE FASIA



Side Fascia is supplied loose in the same length as the side frame.

## TOP FASCIA & TOP FASCIA RETURNS

Top Fascia is supplied with returns for both inside and outside mounts and cut at 45°. The total length of the top fascia is the length of header + 20mm.

The length of Top Fascia returns is the width of the header (100mm)+10mm.

Please specify the width of top fascia i.e. 54mm for inside mount or 100mm for outside mount.

If the length of top fascia is more than 3810mm, it will be split into three pieces with the length of left and right pieces are shorter than the centre piece.

Both top fascia and top fascia returns are supplied loose.

The mounting block is also supplied loose.

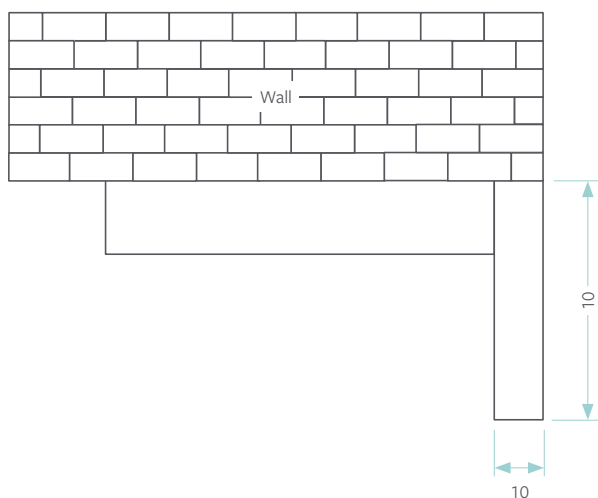

Inside Mount

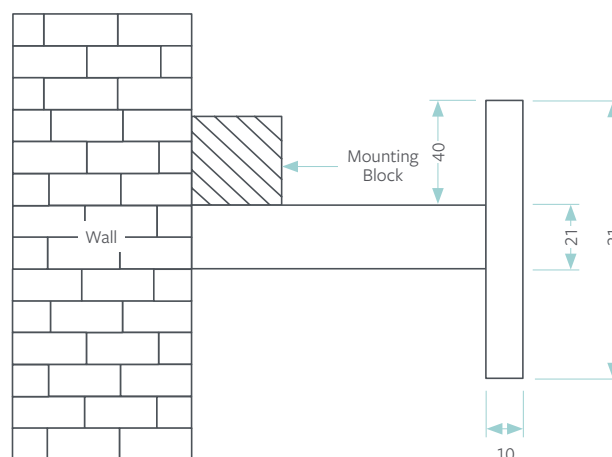

Outside Mount

# BI-FOLD TRACKING SHUTTER

## NETT WIDTH MEASUREMENT FOR BI-FOLD TRACKED SHUTTER

To avoid unforeseen problems, it is very important to provide the nett measurements of height and width of the window opening.

As the nett height measurement is already described above (with/without bottom board, in/outside mount), the following chart shows how to measure the nett width.

Please note that there is a 8mm gap between the panel and the side frame, it is the clearance needed for the panel to turn when it is being folded.

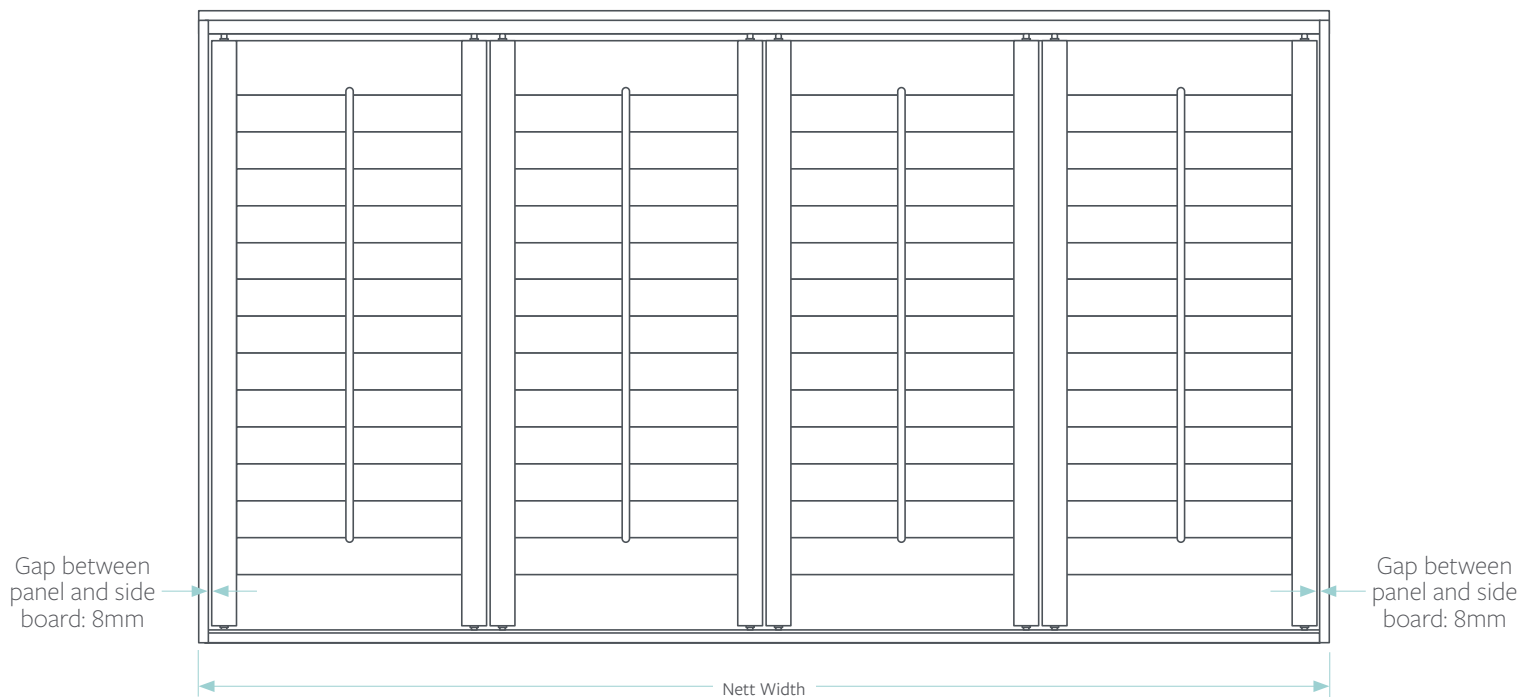

# BI-PASS TRACKING SHUTTER

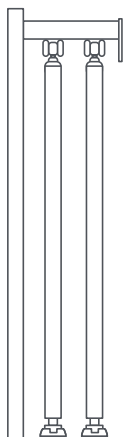

By-Pass Tracked Shutter is shutter panels that can slide effortlessly across a discreet track system.

To avoid unforeseen problems, it is very important to provide the nett measurement of height and width of the window opening.

In the charts below, you will see how to measure the nett height and width for By-Pass Tracked Shutter.

## NETT HEIGHT MEASUREMENT

### RAISED BOTTOM TRACK WITHOUT BOTTOM BOARD

The raised bottom track sits directly on the floor without bottom board. The bottom clearance will be 16mm between the panel's bottom and the floor.

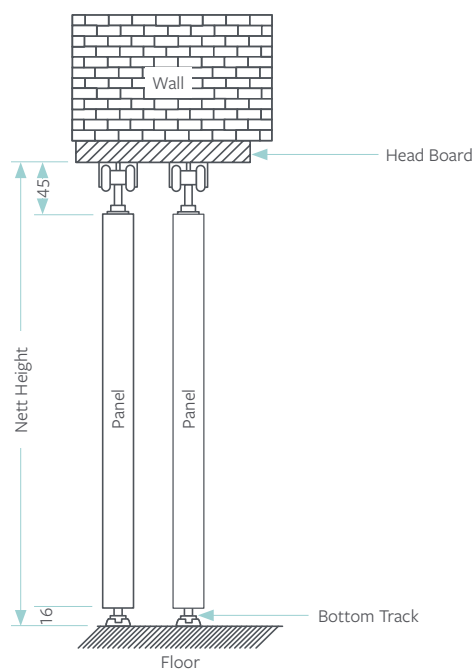

Inside Mount

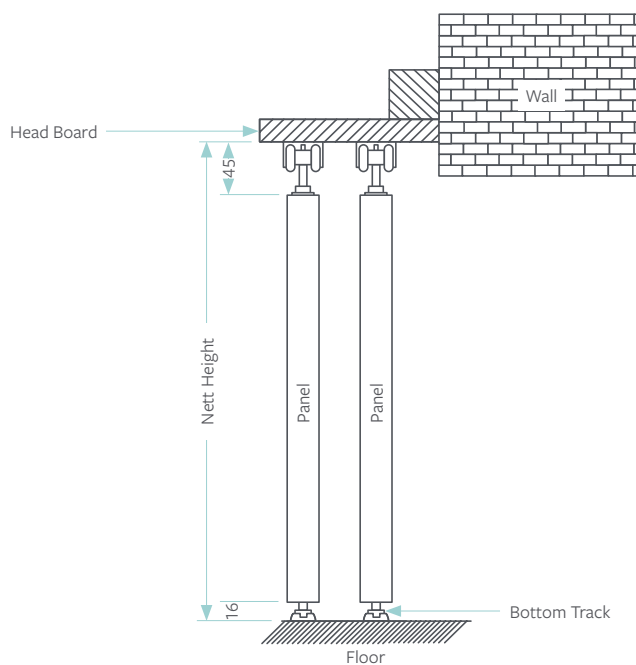

Outside Mount

*\*The thickness of the head board is 21mm.  
The thickness of the bottom board is 21mm.*

# BI-PASS TRACKING SHUTTER

## RAISED BOTTOM TRACK WITH BOTTOM BOARD

The raised bottom track sits directly on the bottom board. The bottom clearance will be 35mm between the panel's bottom and the floor.

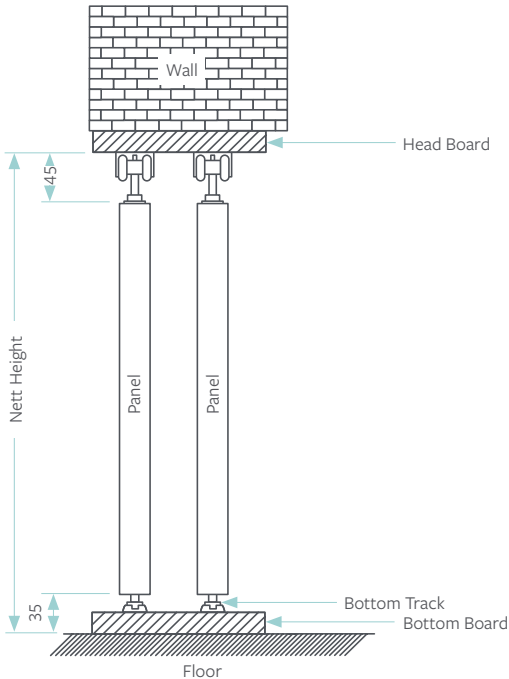

Inside Mount

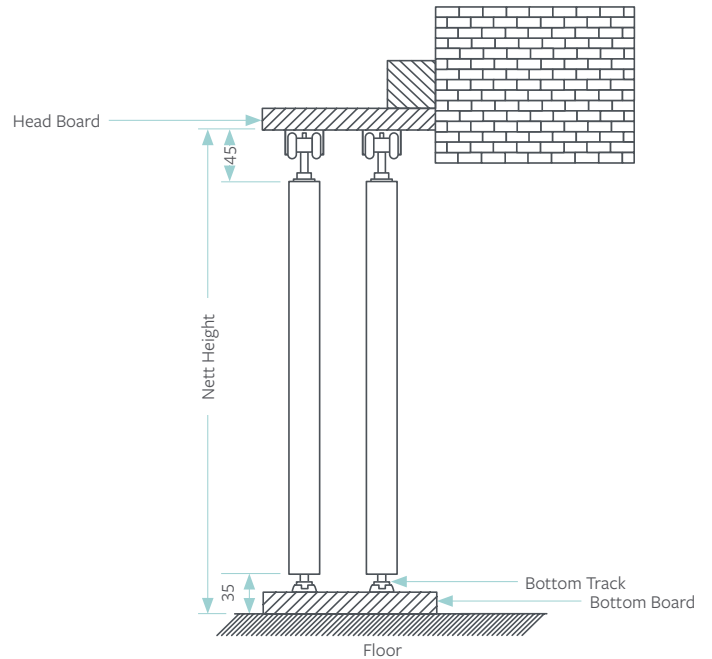

Outside Mount

## RECESSED BOTTOM TRACK WITH BOTTOM BOARD

The Bottom Track is recessed fully into bottom board. The bottom clearance is 27mm between the panel's bottom and the floor.

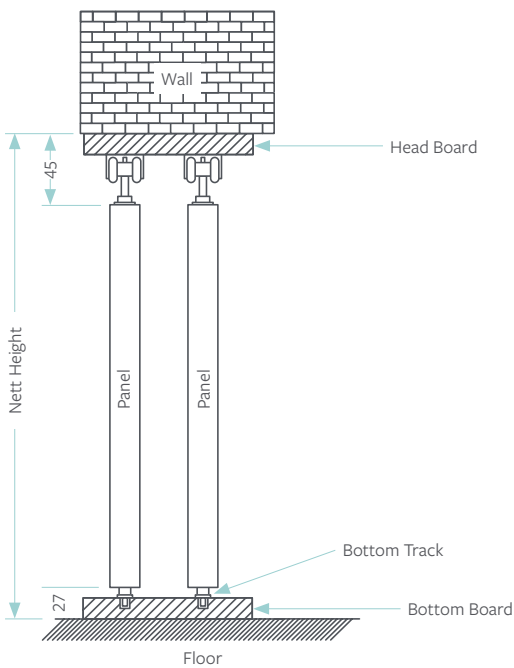

Inside Mount

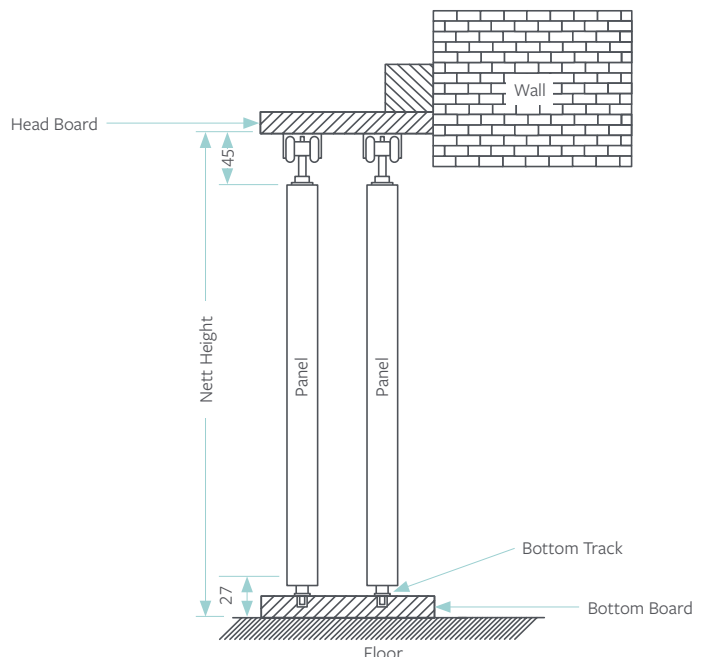

Outside Mount

# BI-PASS TRACKING SHUTTER

## TOP TRACK POSITION

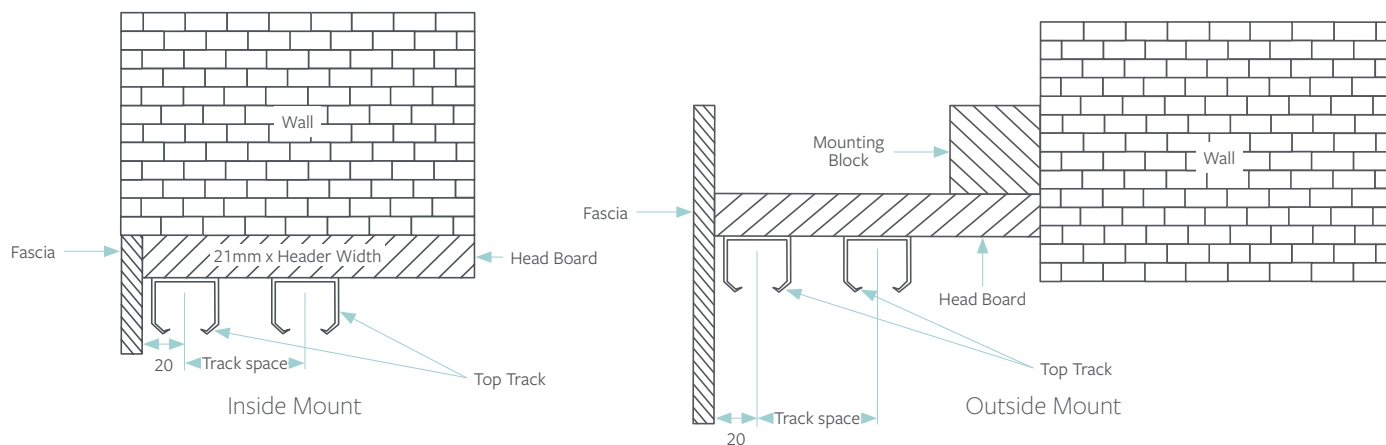

## HEADER WIDTH AND TRACK SPACE FOR DIFFERENT LOUVRE SIZE

LOUVRE SIZE	HEADER WIDTH		TRACK SPACE		
	CLOSE	OPEN	CLOSE BY-PASS	STANDARD TILT ROD	CLEARVIEW ROD
63mm	160mm	160mm	50.8mm	90mm	70mm
76mm	160mm	180mm	50.8mm	102mm	81mm
89mm	160mm	200mm	50.8mm	114mm	92mm

## HEADER & SIDE FRAME

The thickness of Header and Side Frames are 21mm.

The width of Header and Side frame are explained on the below chart. For header length more than 3657mm, we will use 2 pieces of the same length components to join together with mitre and dowel.

The top track will be pre-assembled onto the header.

# BI-PASS TRACKING SHUTTER

## BOTTOM TRACK POSITION

Raised Bottom Track sits at 20mm from the edge of bottom board to the centre of it.

If there's no bottom board, then the bottom track will have to be aligned with the top track manually.

We will pre-attach double adhesive tape (1.5mm thick) onto the Raised bottom Track . Screws will be supplied as well to strengthen the installation.

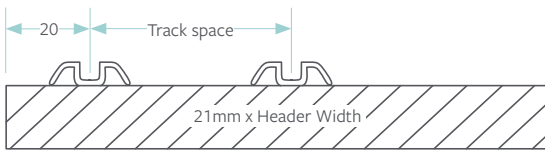

Recessed Bottom Track is recessed fully into bottom board at 20mm from the edge of bottom board to the centre of it.

If there's no bottom board, then the bottom track needs to be aligned with the top track and recessed into the floor manually.

For Recessed Bottom Track, we will supply screws as we don't recommend double adhesive tape.

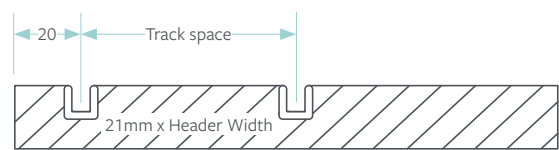

The Track Space on bottom track is the same as the one on the top track.

Both Raised and Recessed Bottom Tracks will be supplied in the same length as the bottom board, or same as the header if the bottom is not used.

Both Raised and Recessed Bottom Track will be supplied loose.

## MOUNTING BLOCK/SUPPORTING STRIP

17.46mm x 17.46mm for side frame.  
38.1mm x 40mm for header.

We will supply the mounting block for both inside and outside mount in the same length with header and side frame

## SIDE FASIA

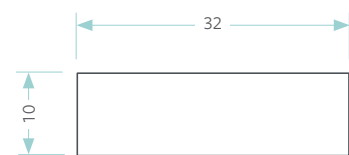

Side Fascia is supplied loose in the same length as the side frame.

# BI-PASS TRACKING SHUTTER

## TOP FASCIA & TOP FASCIA RETURNS

Top Fascia is supplied with returns for both inside and outside mounts and cut at 45°. The total length of the top fascia is the length of header + 20mm.

The length of Top Fascia returns is the width of the header (100mm)+10mm.

Please specify the width of top fascia i.e. 100mm for inside mount or 140mm for outside mount.

If the length of top fascia is more than 3810mm, it will be split into three pieces with the length of left and right pieces are shorter than the centre piece.

Both top fascia and bottom fascia returns are supplied loose.

The mounting block is also supplied loose.

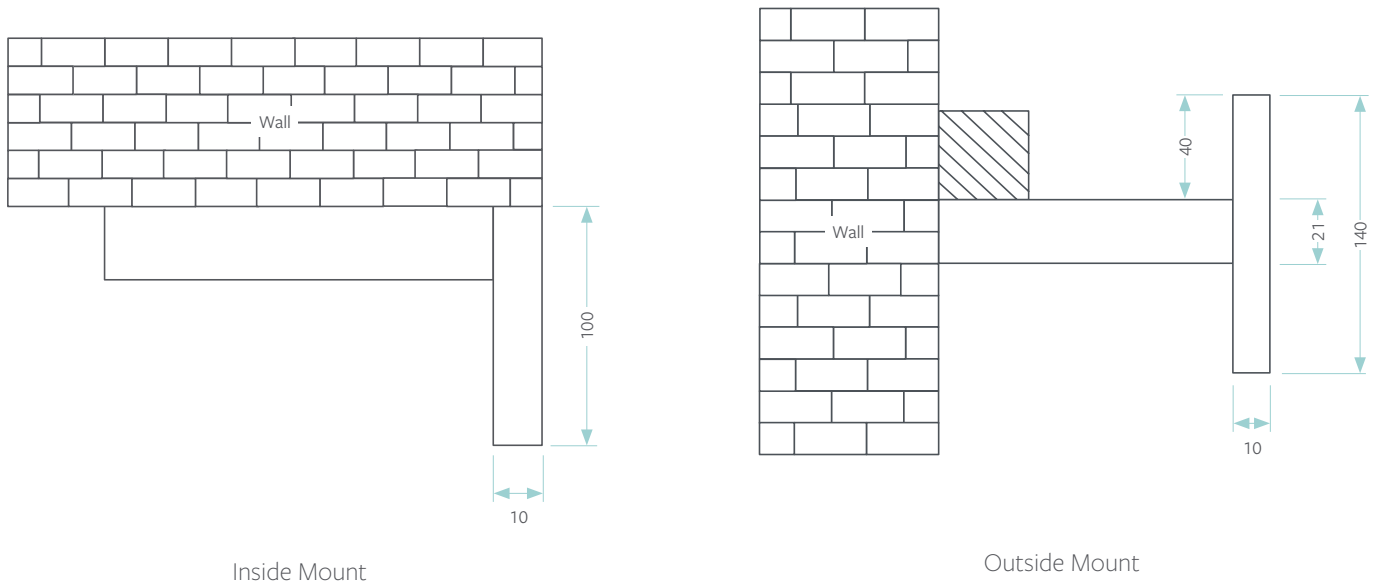

## LIGHT STRIP FOR BY PASS -LOUVRE OPEN

The function of Light Strip is to cover the gap between two sliding panels with louvre open option.

The gap between two Light Strips is +/-5mm.

The dimension of Light Strip depends on louvre size and tilting system.

Light Strip will be supplied loose.

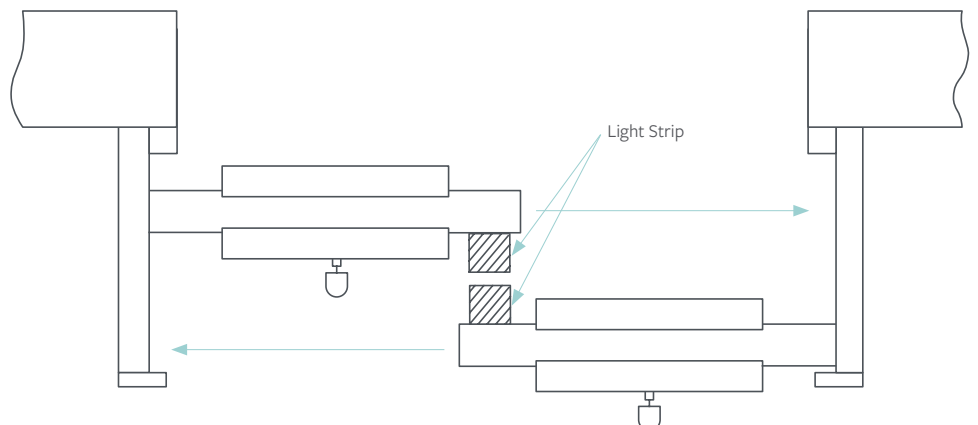

# TERMS & CONDITIONS

## 1. Buyer/Seller

- 1.1 In these conditions “the Seller” means Santa Fe Shutters and “The Buyer” means the person, firm or company placing an order for goods or services, which are subject to these terms and conditions which are not variable except in writing signed by the Seller.
- 1.2 These conditions of sale together with the particulars contained in the order acceptance save where stated otherwise and any special conditions agreed by the Seller in writing constitute the entire contract between the Buyer and the Seller.
- 1.3 Periods of time referred to in these conditions of sale shall be of the essence.

## 2. Quotation

- 2.1 All quotations by the Seller represent an invitation to the Buyer to place an order and do not constitute a legal offer. The purchase order will be regarded as the offer and the Seller’s order acceptance will be regarded as binding. No alternative terms and conditions will be considered or accepted by the Seller.
- 2.2 All prices are quoted without commitment and are subject to alteration or withdrawal by the Seller without prior notice. Orders can be accepted on the condition that the prices charged are those ruling at the date of order unless the Seller specifically agrees in writing to engage a fixed price contract.

## 3. Delivery

- 3.1 Delivery times are estimates only and not of the essence. Whilst every effort is made to ensure due performance, the Seller cannot accept responsibility for damages or consequential loss or damage arising out of delay or failure to deliver by the specified date.
- 3.2 If a Buyer fails to take delivery of the goods or any part of them on the due date for any reason whatsoever the Seller will be entitled to charge for re-delivery and upon notice to the Buyer delivery will be deemed to have taken place and the Buyer will pay to the Seller all costs and expenses including storage and insurance charges. Any delay or failure to deliver by the Seller will not entitle the Buyer to refuse delivery or to repudiate the contract and the full price will be payable to the Seller without deduction.
- 3.3 Non delivery or damage pilferage in transit must be reported in writing to the Seller within 5 days of receipt of invoice or advice of despatch. Where goods are collected from the Seller by the Buyer or a third party nominated by the Buyer the risk in goods passes to the Buyer upon delivery to the Buyer or such third party. Thereupon liability of the Seller in the goods for loss or deduction, breakages, shortages or non delivery shall cease.
- 3.4 The address for delivery shall be the Buyer’s address as stated on the order unless otherwise stated between the parties in writing.
- 3.5 Once the goods are delivered and signed for either in good condition or unchecked, the Seller cannot accept responsibility for any damage to said property.

## 4. Retention of Title

- 4.1 The goods shall remain the property of the Seller until full payment has been received (each order being considered as whole).
- 4.2 The Buyers right to possession of the goods will cease at the earliest of the following date:
  - 4.2.1 On expiration of any agreed period of credit, or due date for payment of any invoice has passed.
  - 4.2.2 If being an individual he commits an act of bankruptcy or makes a proposal to his creditors or does anything which would entitle a petition for a bankruptcy order to be made, or the Seller believes on reasonable grounds that the same is likely to occur.
  - 4.2.3 If being a company it goes into liquidation or does anything or fails to do anything which would entitle a receiver to take possession of any assets or which would entitle any person to present a petition for winding up or to apply for an Administration order, or the Seller believes on reasonable grounds that the same is likely to occur.  
The Seller will have the right if paragraphs 4.1 applies:  
To repossess the goods  
To use or sell all or any of the goods  
To enter any premises of the Buyer, for the aforesaid purposes

## 7. Payment Terms

- 7.1 Payment terms apply. A deposit of 50% of the total cost must be paid to Santa Fe Shutters at the time of placing the order. This is non-refundable. The remainder of the payment must be made in full on final installation of the shutters.
- 7.2 Hampton shutter orders, for pro-forma customers, 100% payment must be paid at time of placing the order. This is non-refundable

# TERMS & CONDITIONS

7.3 Credit facilities are available on request. Terms and conditions of the credit provider will apply.

## 8. Returns

8.1 Any defective good must be notified within 5 days of being delivered/installed. Goods delivered and signed for in “perfect condition” cannot be returned.

## 9. Liability

- 9.1 All goods should be carefully inspected prior to installation. The Buyer must check that the shutters, the frames and ancillary fittings including operation method are in accordance with the purchase order both for colour and design prior to installation. The Seller cannot accept any responsibility in circumstances where the Buyer is not present at the delivery/ installation address.
- 9.2 The Buyer must check that shutters are to colour sample prior to installation. The Seller cannot guarantee precise colour matching against samples; most of our products are made from natural materials. Minor imperfections not readily apparent at a distance of 1000mm under ordinary light will not be accepted as defects. Colour matching of finishing products e.g. paint, cannot be guaranteed although every reasonable effort will be made to ensure the accuracy of the finished product.
- 9.3 The Seller cannot guarantee the goods against fading or darkening especially as a result of exposure to sunlight where fading or darkening may occur. Santa Fe Shutters are not guaranteed against extreme damp, warm or variable conditions.
- 9.4 The Seller reserves the right to withdraw any products and colours at any time without prior notice and cannot be held responsible for any consequences, caused by the withdrawal of such products.
- 9.5 Under no circumstances, except in respect of death or personal injury caused by the Sellers negligence does the Seller accept liability for consequential loss, damage or costs or expenses, howsoever arising and any liability for any such consequential loss is hereby specifically excluded. Should a claim be made the Sellers liability is limited to the value of the order placed by the Buyer.
- 9.6 The Seller gives no warranty as to the fitness of the product supplied for any other purpose other than that of an internal window dressing as surveyed by the company; other installation and uses are the risk of the Buyer.
- 9.7 Tolerance levels of overall panel specifications are plus or minus 1mm, and the product will not be considered defective if falling within the size range. Warp on any component part, vertical or horizontal, shall not exceed 2mm per lineal metre and shall not be considered defective if within this tolerance.
- 9.8 Limitations. It is recommended that panels be ordered within our normal size range. For example, panels above 1700mm in height are ordered with a mid rail, and that panel widths do not exceed 600mm for faux wood shutters. We may exceed the limitation at your request, but in doing so we cannot accept responsibility for any problems that result.
- 9.9 If the Buyer is not on site when property is surveyed or installed the shutters will be fitted in accordance to our standard practices unless agreed prior to confirmation. If the Buyer chooses to install against our recommendation then liability will be theirs.
- 9.10 Upon installation the Seller shall not be responsible for the moving or the relocation of any electrical wiring which may be obstructing any installation process. It is the responsibility of the Buyer to relocate any electrical wiring and leave a clear opening before installation can proceed.
- 9.11 The Seller shall order in accordance with the Buyer's Order Acceptance. As soon as the Seller has placed the Buyer's order, Order Acceptance shall become binding in the Buyer's choice of product, design option, colour etc. Any alteration that the Buyer wishes to make will incur the re-ordering and therefore shall be at the expense of the buyer.
- 9.12 If installers are paid by the Buyer the Seller cannot except liability for any damage or defective installation.. The foregoing is in substitution for all other terms, express or implied relating to the quality or fitness for purpose, and all such terms are hereby excluded. This does not, however, affect the consumer's statutory rights.

For full terms and conditions please visit: [www.santafeshutters.co.uk/terms](http://www.santafeshutters.co.uk/terms)