

# MADISON

---



## FEATURES & BENEFITS

Meticulously crafted to the highest standard, Santa Fe Madison shutters are offered across our portfolio of shutter options: Full Height, Tier on Tier, Cafe Style, Blockout, Solid and Shaped shutters including Bifold and Bypass Tracks.

### MADISON

Madison offers a range of painted colours including whites, creams and greys; and wood stains ranging from light to dark wood tones. Available in 63mm, 76mm, 89mm and 114mm. As wood is a natural insulator, energy efficiency properties are enhanced with these beautiful shutters. A custom colour option is also available for Madison shutters enabling paint colours to be matched for an additional surcharge.

FULL HEIGHT	TIER ON TIER	CAFE	BAY	SHAPED	TRACK	FRENCH DOOR	SOLID	BLOCKOUT
✓	✓	✓	✓	✓	✓	✓	✓	✓

### MADISON HYBRID SHUTTERS

Madison Hybrid Shutters are the perfect blend of durability and exquisite craftsmanship. Our Hybrid Shutters offer a robust PVC frame boasting inherent water-resistant properties, increasing the durability and performance of Madison Shutters in moist environments.

FULL HEIGHT	TIER ON TIER	CAFE	BAY	SHAPED	TRACK	FRENCH DOOR	SOLID	BLOCKOUT
✓	✓	✓	✓	✓	✓	✓	✓	✗



## SHUTTER STYLES

- **Full Height**  
Designed to dress the full height of the window. A functional, yet stylish feature for any home. Also available with a mid-rail, enabling the shutter louvres to be separated
- **Café**  
Ideal for rooms where total privacy is not required. Café style shutters are fitted to the lower section of the window.
- **Tier on Tier**  
Using two sets of shutters, each tier can be operated independently offering ultimate light control.
  - Tier on Tier shutters offer the optimal light and privacy control, however without the proper design Tier on Tier shutters will sag and perform improperly.
  - A horizontal T-post will eradicate the light gap and facilitate easier installation.

## SHUTTER TERMS

- **Bi-fold**  
Shutter panels where two panels are hinged together in order to fold up together.
- **Café frame**  
A standard frame style where shutters cover the bottom half of the window and the top half are open. Café frames are available with a 3-sided or 4-sided frame.
- **Mid Rail**  
A horizontal shutter panel component that separates a single panel into two or more sections that may be opened individually.
- **Tier on Tier**  
Shutter configuration where two panels or groups of panels are mounted separately so they can be opened independently from each other.
- **Solid Shutter**  
Shutter panel without louvres making it a single solid piece
- **Frames**  
Profiles used to frame the window opening, providing a mounting surface for the shutter panels. Frames can be mounted on the inside or outside of the windowsill, depending on the frame style.
- **Inside Mount**  
For windows that are square, the frame is mounted or partially mounted inside the recessed portion of the window opening.
- **Louvre**  
A solid profile that rotates for light and privacy control. Louvres are available in 63mm, 76mm, 89mm and 144mm widths.
- **Mouse Hole**  
The rounded cut-out in the top shutter panel rail designed to fit the tilt rod. This hole allows complete closure of the louvres, providing a superior fit.
- **Outside Mount**  
A mounting method where the frame is mounted to the wall or outside casing of the window opening.

- Tier on Tier shutters must be designed so that the width of the panels is less than the height of the panels.
- Tier on Tier shutters must have a four-sided frame.
- There is a surcharge for Tier-on-Tier shutters

- **Shaped Shutters**  
Santa Fe Shutters offers a wide range of shaped shutter options that can perfectly fit your window shape.
- **Blockout Shutter**  
Through the development of a unique shutter frame, a blockout cellular blind can be placed behind your shutter. This enables enhanced blockout properties. Perfect for turning day into night in bedrooms.
- **Rails: Top & Bottom**  
The top and bottom horizontal framework of the shutter panel.
- **Reveal**  
The distance between the innermost edge of an outside mount frame and the outside edge of the window opening.
- **Stile**  
The vertical sides of the shutter panel.
- **Astragal Stile**  
The vertical sides of the shutter panel designed to cover the light-gap where two panels meet. A small lip offers superior light control.
- **T-Posts**  
Profiles used for extra support within a frame system. T-posts can be positioned vertically or horizontally.
- **Centre Tilt Rod**  
The Centre Tilt Rod is attached to the front of the Shutter panel, allowing you to rotate the louvres open or closed for light and privacy control.
- **Clearview Tilt Rod**  
Clearview Tilt Rod is a metal rod secured to the back of the panel giving an unobstructed view from the front of the panel.
- **Off-Set Tilt Rod**  
The tilt rod is not placed in the centre of the shutter panel. The tilt is attached to the louver panels at either left or right side of the panel.
- **Rack & Pinion (RPS)**  
A concealed tilt mechanism within the stile of the shutter.
- **Light Control and Privacy**  
The privacy and light control from your shutter will depend on the size of louvre. Larger louvres will allow for more light, while smaller louvres will provide more privacy. Shutters are a light diffusing product rather than blockout, due to their design, light will enter the room where the louvre meets the edge of the frame. To ensure complete blockout, we recommend the installation of a blockout roller or cellular blind in the recess.

# SHUTTER SPECIFICATION

	MADISON	MADISON HYBRID
Composition	Paulownia	PVC Frame, Paulownia Stile & Louvre
Weight	425kg/m <sup>3</sup>	Paulownia 425kg/m <sup>3</sup>  PVC 600kg/m <sup>3</sup>
Colours	13 Painted and 12 Stains	13 Painted
Custom Colour	Yes	No
Full Height	Yes	Yes
Tier on Tier	Yes	Yes
Café Style	Yes	Yes
Track Options	Bifold and Bypass	Bifold and Bypass
Blockout shutter	White 25mm cellular blockout blind within shutter frame.	No
Solid shutter	Solid / shaker / combined (mix of louvres & solid panels)	Solid / shaker / combined (mix of louvres & solid panels)
Special Shapes	Yes	Yes - restricted frames available
French Door Cut Out	Yes	Yes
Uneven Panels	Yes (Double hinged panels will be sized equally unless measurements are provided)	Yes (Double hinged panels will be sized equally unless measurements are provided)
Stile Profile	Butt and Astragal (Rabbit is available on bi-fold and tri-fold shutters)	Butt and Astragal (Rabbit is available on bi-fold and tri-fold shutters)
Louvre Type	Elliptical and Urban	Elliptical and Urban
Louvre Width	63mm, 76mm, 89mm & 114mm Elliptical 63mm, 76mm & 89mm Urban	63mm, 76mm, 89mm & 114mm Elliptical 63mm, 76mm & 89mm Urban
Stile Width	38mm	38mm
Stile Thickness	27mm	27mm
Rail Thickness	20mm	20mm
Minimum Panel Height	250mm	250mm
Maximum Panel Height	3000mm (1st Mid Rail over 1800mm, 2nd Mid Rail over 2400mm)	3000mm (1st Mid Rail over 1800mm, 2nd Mid Rail over 2400mm)
Mid Rail	<b>Elliptical</b> 76mm Mid Rail for 63mm, 89mm & 114mm Louvre 66mm Mid Rail for 76mm Louvre <b>Urban</b> 82mm Mid Rail for 63mm & 89mm Louvre 70mm Mid Rail for 76mm Louvre	<b>Elliptical</b> 76mm Mid Rail for 63mm, 89mm & 114mm Louvre 66mm Mid Rail for 76mm Louvre <b>Urban</b> 82mm Mid Rail for 63mm & 89mm Louvre 70mm Mid Rail for 76mm Louvre
Tilt Rod	Centre, Offset, Clearview and Rack & Pinion (RPS 10% uplift) Urban available as RPS only.	Centre, Offset, Clearview and Rack & Pinion (RPS 10% uplift) Urban available as RPS only.
Panel Width (Min)	200 mm	200 mm
Single Panel Width (Max)	890mm (750mm on Bypass Track)	890mm
Max Width per set of hinges	660mm per panel - two panels hinged 450mm per panel - three panels hinged	660mm per panel - two panels hinged 450mm per panel - three panels hinged

MANUFACTURING TOLERANCE: -2MM / +2MM  
OFFSET TILT IS 38MM FROM EDGE OF SLAT.

Please note: When ordering shutters for the same room, where possible, we recommend ordering these to the same height, or that you request the shutters to align in the special instructions.

# SHUTTER SPECIFICATION

## MAX NUMBER OF PANELS

STYLE	MAXIMUM NUMBER OF PANELS HINGED FROM ONE SIDE OF FRAME
Full Height	3
Café	3
Tier on Tier	3
Bifold Track	8

## SHUTTER REFERENCE

STYLE	MIN WIDTH	MAX WIDTH (WITHOUT T POST)	MAX WIDTH (WITH T POST)	MIN HEIGHT	MAX HEIGHT
Full Height	250	2750	3500	295	1800
Full Height with midrail	250	2750	3500	295	3049
Cafe	250	2750	3500	295	3049 (with midrail)
Tier on Tier	250	2750	3500	295	3049

# OUR SHUTTER

## FRONT VIEW OF LOUVRE SIZES

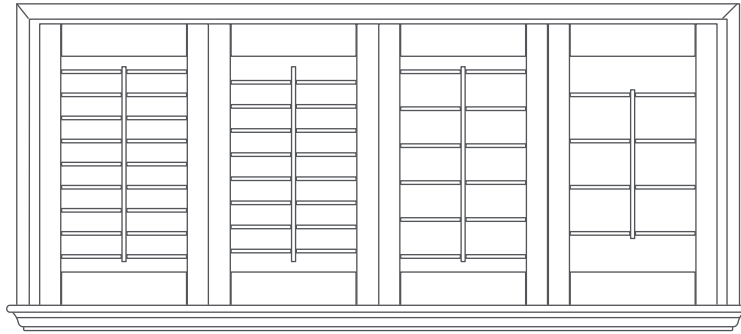

**63MM**  
Elliptical & Urban

**76MM**  
Elliptical & Urban

**89MM**  
Elliptical & Urban

**114MM**  
Elliptical Only

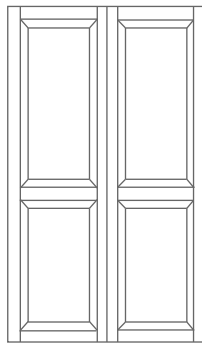

Solid panel

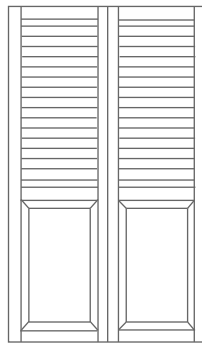

Combination

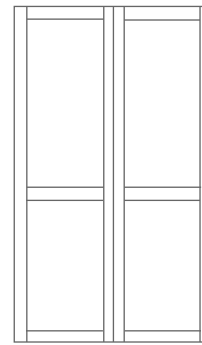

Shaker

### AVAILABLE FITTING OPTIONS

- No Frame/ Panel only
- L Frames
- Z Frames (Inside Mount Only)
- Camber Deco (Outside Mount Only)

### TILT OPERATION

- Centre (Elliptical louvre only)
- Offset (Elliptical louvre only)
- Clearview (Elliptical louvre only)
- Rack and Pinion (Elliptical and Urban louvre)

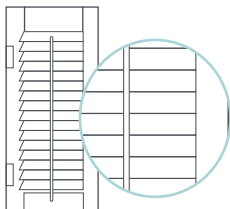

Centre Tilt Rod

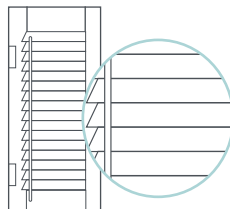

Offset Tilt Rod

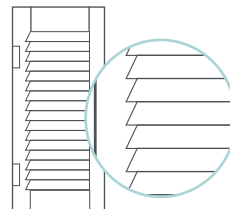

Clearview Tilt Rod

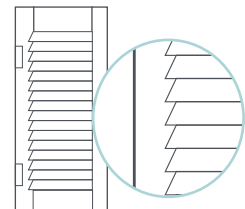

Rack and Pinion  
Tilt Rod

# SANTA FE WARRANTY

## WHAT IS COVERED IN THE WARRANTY

- Decora Blind Systems warrants to the original purchaser that each custom shutter product, properly installed and maintained in the window or door opening for which it was made, will be free from defects in materials and workmanship.
- There is a 3-year warranty on our Madison shutters. 1-year warranty on blackout cellular blind.
- Any claims for incorrect or defective products must be brought to our attention within 5 days of receipt, and before shutters are altered in any manner or installation is attempted.
- If the product is found to be defective in material or workmanship under normal use, or products do not meet our quality standards, Decora Blind Systems will, at its discretion, repair or replace any defective parts or components without charge, provided that the original purchaser ships the product to the designated repair facility.
- This warranty does not imply automatic replacement of any product from Decora Blind Systems.

**The below options can be manufactured outside of warranty through written confirmation from the customer:**

- No split tilt (Clearview & RPS) wanted when shutter is over 1250mm.
- Needing to exceed the maximum panel width.
- Not wanting to have T Posts when they are required, ties into the above.
- Removing the requirement for a midrail when the shutter is over height.

## WHAT IS NOT COVERED IN THE WARRANTY

- This warranty does not cover conditions or damages resulting from accidents, alterations, misuse, abuse, misapplication, fire, flood, or other natural disasters, failure to follow use, care of installation and maintenance instructions, settlement of structural defects of the building or shutters that have ordered outside recommended specification.
- Shutters are light controlling but not blackout. Varying levels of light filtration between louvres, frames and panels may occur. To ensure complete blackout, we recommend the installation of a blackout roller or cellular blind in the recess.
- Installing at location that will result in continued heat exposure over high degrees that cause warpage and shrinkage of the shutters.
- Decora Blind Systems will not be liable for any incurred costs, such as travel costs and time, nor for damages or loss to other property

## SANTA FE SHUTTER IMPERFECTIONS

- Santa Fe Shutters are manufactured to industry standards. Minor imperfections or blemishes not visible at an 90 degree angle from 1.5m back under natural lighting conditions are not considered defects.
- Shutters will only be considered for repair if there are any marks or any discolouration visible from 1.5m back.
- Touch up paint will be provided in box of shutter.
- Madison shutters are manufactured using real wood, therefore they are likely to display natural characteristics such as knots and grain patterns, meaning no two shutters will be the same. Painted finishes may display minor imperfections on the surface due to the natural characteristics, while stained finishes can have colour variation due to the natural wood.

# MADISON WARRANTY

## CANCELLATION AND MODIFICATION

The prompt production of any order requires a strict manufacturing scheduling. Therefore, once an order has been submitted cancellations will not be accepted and the company who placed the order will be liable for the full cost of the order. Changes will be allowed only if the order has not gone into production (this usually occurs within 48 hours of submitting an order). Any costs and/or expenses resulting from a cancellation or change will be charged to the company who placed the order.

## REPLACEMENT OF PARTS OR REPAIRS

The factory reserve the right to change the design or discontinue any components. If an exact replacement part is not available, then the factory reserve the right to substitute a part or parts of equal quality at its sole discretion.

## MAINTENANCE AND CLEANING

To clean your Santa Fe Shutters we advise the following:

Dust - Dry Cloth or vacuum using the soft brush attachment for your vacuum cleaner.

Dirty Marks - use a damp cloth/baby wipe - we do not recommend the use of abrasive cleaning products on shutters.



## LOUVRE PROFILE

### Madison & Madison Hybrid

63mm Urban



63mm Elliptical



76mm Urban

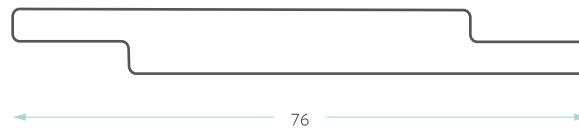

76mm Elliptical

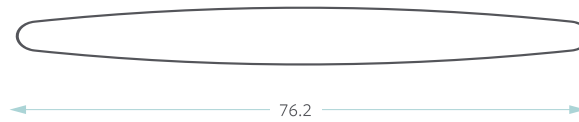

89mm Urban



89mm Elliptical



114mm Elliptical

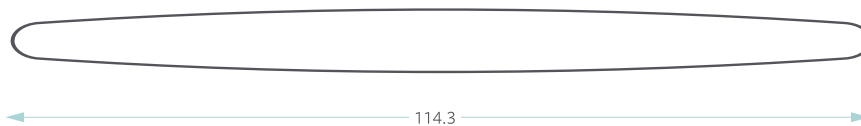

# STILE TYPES

\* All measurements in mm

A single shutter panel is made using Butt stile. To reduce the amount of light entering a room, where two panels meet together Astragal stile is used as standard.

38MM BEADED BUTT STILE

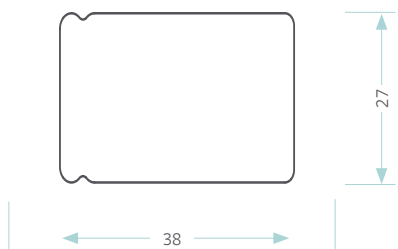

38MM BEADED ASTRAGAL STILE

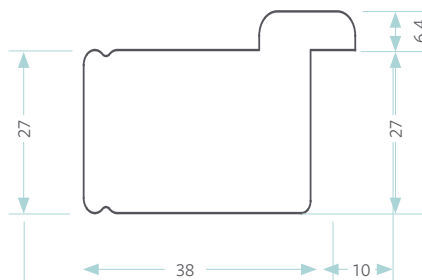

38MM FLAT BUTT STILE



38MM FLAT ASTRAGAL STILE

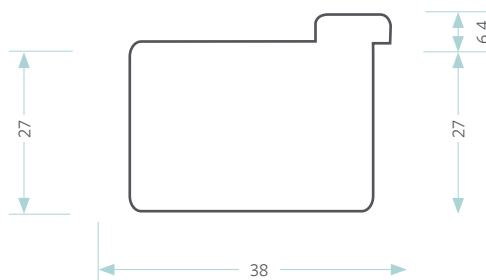

38MM FLAT RABBET STILE

*Flat 38mm Rabbet stile is only available on tri-fold shutters*

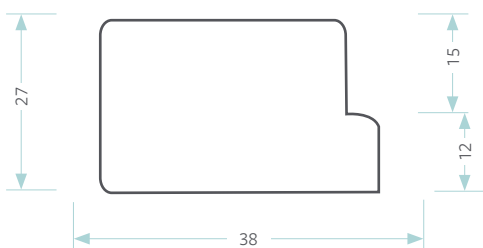

38MM BEADED RABBET STILE

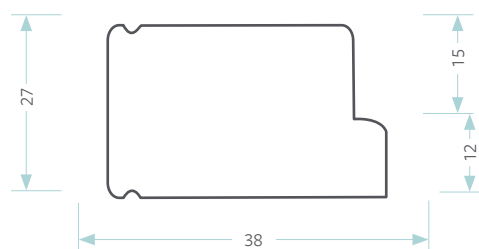

## TOP/BOTTOM RAIL

Mortice and tenon joints are used when fixing Top & Bottom rails to the Stiles. This produces an extremely strong construction.

The size of the top and bottom rail is dependent on a number of factors, including panel height, louvre sizes. The factory will decide on the rail sizes based on the structural requirements of the panels.

Please note: For café style frames – no pre drilled holes will be made on the top frame.

## MID RAIL

Mid rails provide strength to taller panels. The 1st mid rail is required when a panel is over 1800mm. A second mid rail is required when a panel is over 2400mm.

### Elliptical

The size of the mid rail for 63mm, 89mm & 114mm Louvre is 76mm

The size of the mid rail for 76mm Louvre is 66mm

### Urban

The size of the mid rail for 63mm & 89mm Louvre is 82mm

The size of the mid rail for 76mm Louvre is 70mm

**Top and bottom rails are the same size, please note placement of the mid rail may vary from requested, please see table below:**

LOUVRE SIZE	DIVIDER RAIL (+/-) TOLERANCE
63mm	+/- 25mm
76mm	+/- 32mm
89mm	+/- 38mm
114mm	+/- 50mm



## SOLID PANEL INFO

\* All measurements in mm

Either a Raised or Shaker style solid panel. Available in Café, Full Height or Tier on Tier.

Shutters made from Paulownia (Hardwood) supplied with either a painted, stained or limewash finish.

Choice of 1 or 2 mid-rails on a solid panel.

Combination style (solid on bottom and louvres on top) can be requested on Full Height Shutters.

Only available with 50.8mm Stile

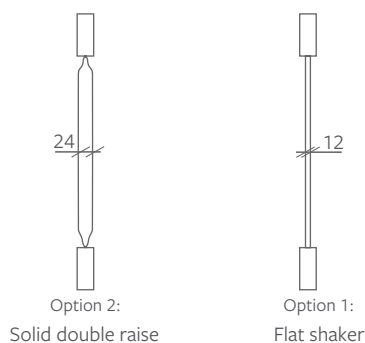

### Solid Shaker

Min width panel is 200mm wide

### 2 side Solid Raised

Min Panel width is 276mm

DESCRIPTION	ABBREVIATION
Full Solid Double Raised	Full DRSP
Cafe Solid Double Raised	Cafe DRSP
Half Solid (combination) Double Raised	Half DRSP
Tier on Tier Solid Double Raised	Tier on Tier DRSP
Full Solid Shaker	Full FSP
Cafe Solid Shaker	Cafe FSP
Half Solid (combination) Shaker	Half FSP
Tier on Tier Solid Shaker	Tier on Tier FSP

## SHUTTER FRAMES & ACCESSORIES

\* All measurements in mm

### TILT RODS

Tilt Rods are used to open and close the louvres, simply by moving up and down. The tilt rod is attached to the louvres by stainless steel staples. Tilt rods are supplied as standard in the centre of the panel. Available on Elliptical only.

Offset tilt rods will be positioned 38mm from the edge of the louvre on the hinge side of the panel as standard. Available on Elliptical only.

A Clearview Tilt Rod is a thin metal bar on the back of the panel. It connects all louvres to allow them to close together. This option allows a more open view through the slats. From the front of panel, move any slat to operate all louvres. Madison Shutters will receive a straight design Clearview rod, this allows for more movement when louvres open/close so as not to place strain on the wood. Clearview tilt is available on Elliptical only.

The Rack and Pinion tilt is fully concealed within the construction of the panel. There is no visible rod mechanism. Slats are adjusted by moving one slat, tilt any louvres and all slats move together. RPS available on Elliptical and Urban.

Shutters over 1200mm high and using RPS or Clearview tilt rods will require a split tilt option.

FULL HEIGHT	TIER ON TIER	CAFE	BAY	SHAPED	TRACK	FRENCH DOOR	SOLID
✓	✓	✓	✓	✓	✓	✓	✓

SLAT SIZE	MAXIMUM NUMBER OF LOUVRES PER CLEARVIEW TILT
63mm	20
76mm	17
89mm	14
114mm	11



Clearview Tilt Option

### LIGHT BLOCK

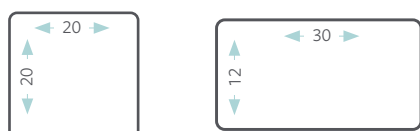

## MADISON L FRAMES

Suitable for shutters installed inside a window recess, or outside recess

**Classic L Frame**  
50mm

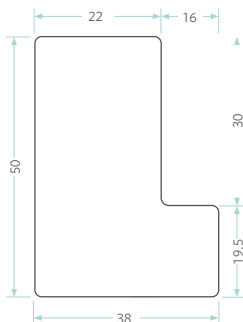

**Classic L Frame**  
60mm

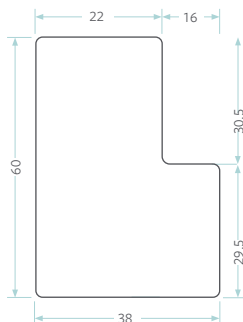

**Classic L Frame**  
70mm

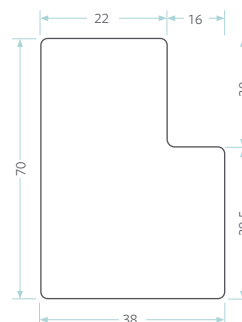

**Classic L Frame**  
80mm

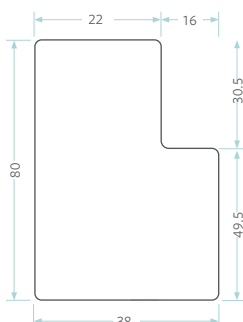

**Classic L Frame**  
90mm

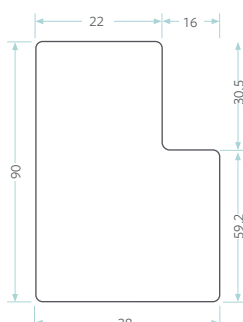

**Vintage L Frame**  
50mm

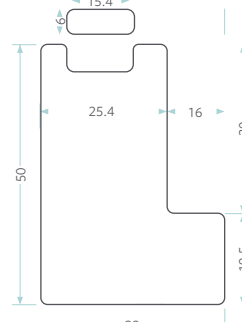

**Vintage L Frame**  
70mm

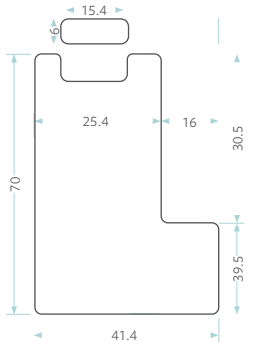

**Plain L Frame**  
60mm

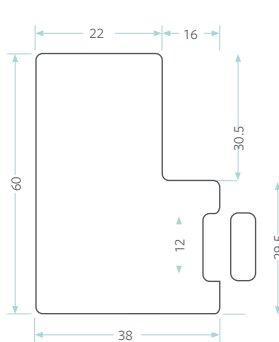

**Vintage L Frame Double Insert**  
60mm

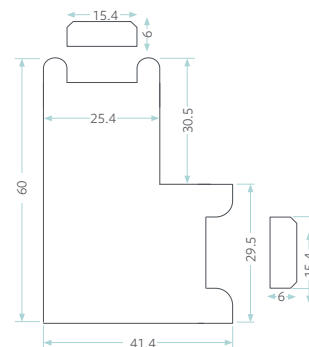

**Blockout Frame**  
100mm

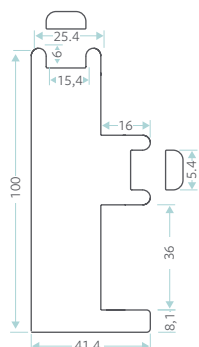

## MADISON Z FRAMES

Suitable for shutters installed to the outer edge of a window recess.

**Classic Z Frame**  
50mm

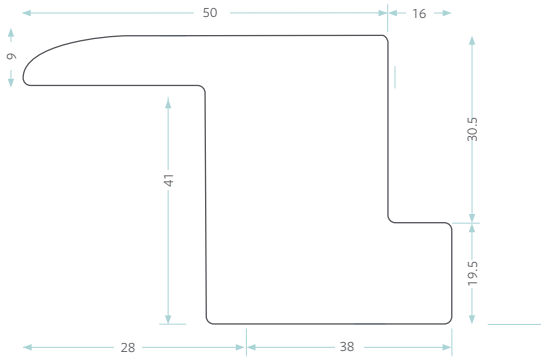

**Bullnose Z Frame 40mm**

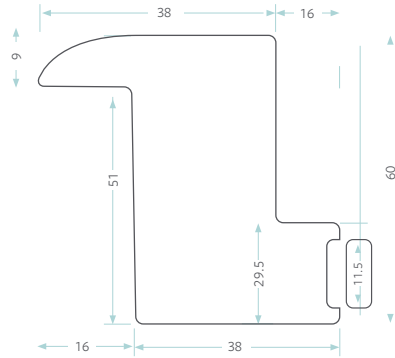

**Embassy Z Frame 50mm**

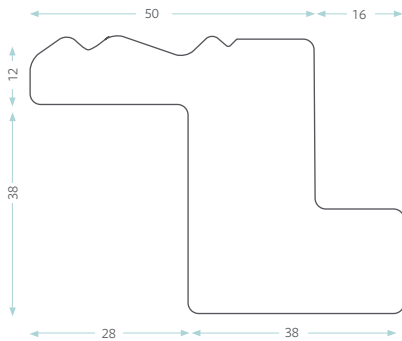

**Regal Z Frame 76mm**

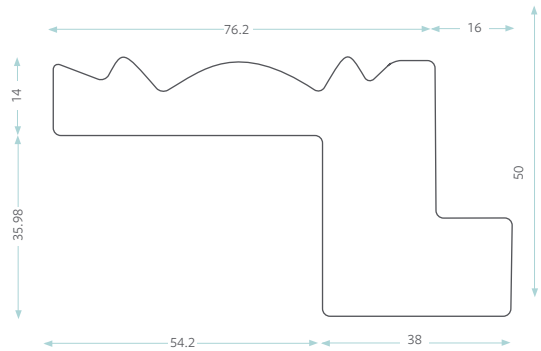

**Regal Z Frame with Insert 76mm**

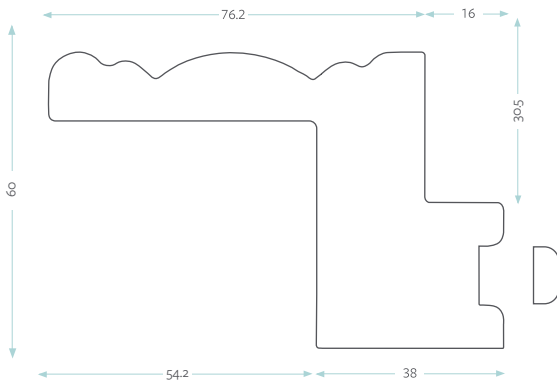

## MADISON VELUX FRAME

Used for shutters installed in roof window

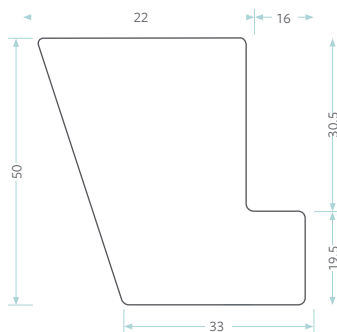

## MADISON CAMBER DECO FRAME

Used for shutters installed outside the recess.

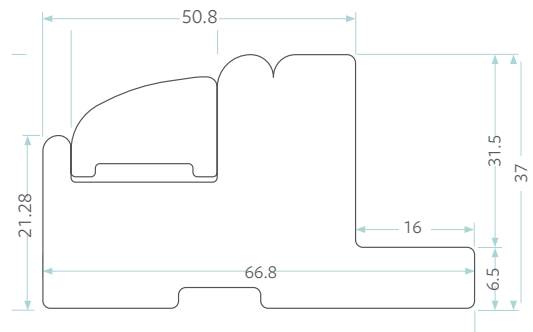

Please note: For all frame types there will be no pre drilled holes on the frame.

## T-POSTS

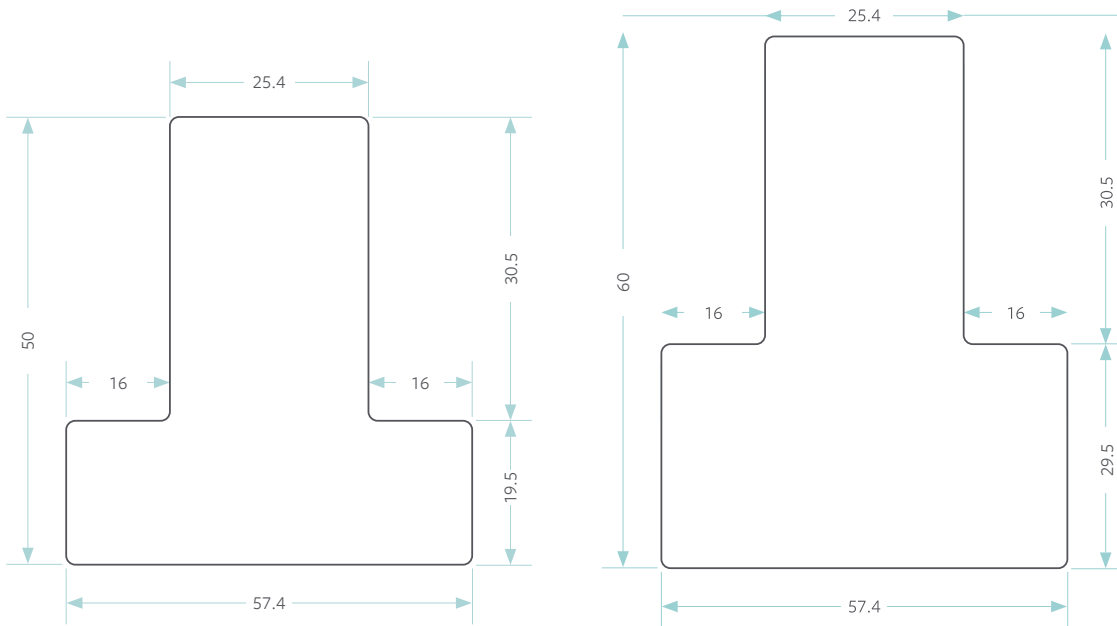

Larger windows can be divided into sections using T posts. Panels can be hinged off a T post or multiple T posts.

Depending on the frame ordered, either a 50mm or 60mm T Post will be supplied.

If Madison Hybrid is ordered, T-Posts will be PVC.

## BUILDOUT FRAME

Buildouts start at 10mm and can be up to 50mm.

Buildouts up to 10mm are supplied pre - pinned onto the frames and the small buildout cannot be removed.

Buildouts 11mm – 50mm are fully painted first and then screwed onto the frames. The customer could decide to remove these bigger build outs and the frame would remain fully painted and finished.

Buildouts are only available in wood, PVC is not available.

## BATTENS (MADISON ONLY)

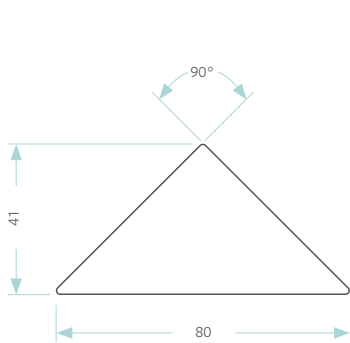
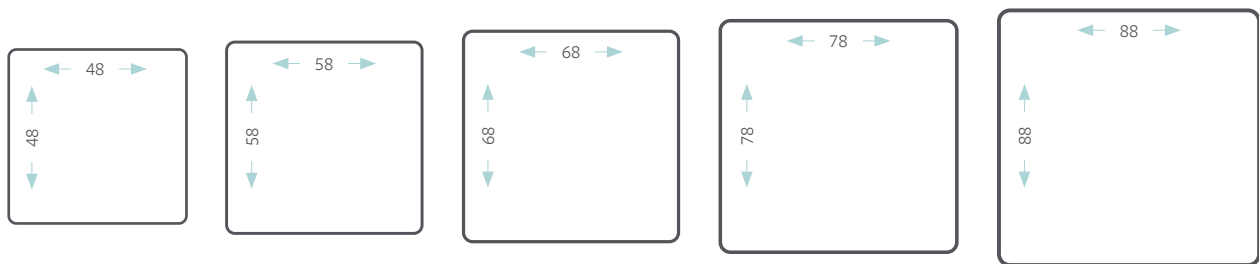

Triangle batten for 90° Corner

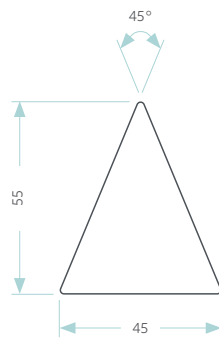

Triangle Batten for 135° Bay

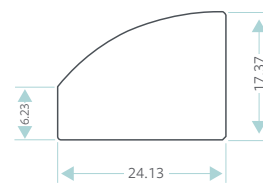

Deco Insert Batten

### Cover stiles

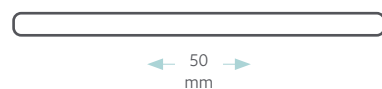
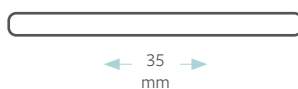

## MADISON HYBRID L FRAMES

Suitable for shutters installed inside a window recess, or outside recess.

**PVC Plain L Frame**  
50mm

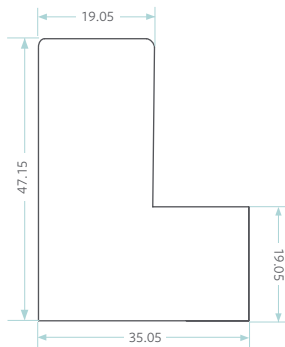

**PVC Plain L Frame**  
70mm

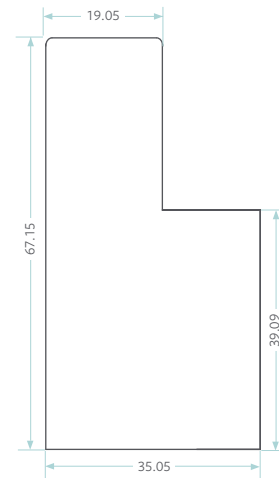

**PVC Plain L Frame with Insert**  
60mm

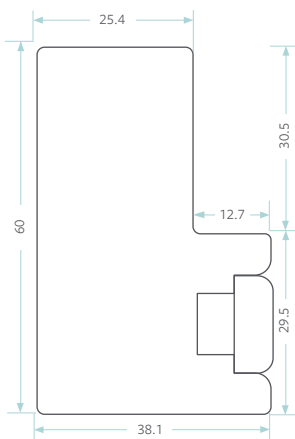

**PVC Vintage L Frame with Double Insert**  
60mm

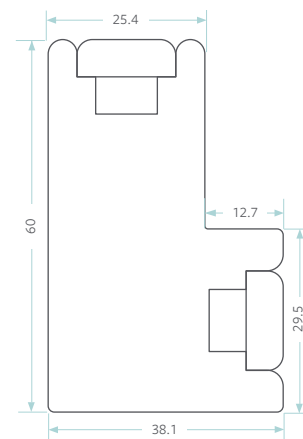

Please note: Hybrid Insert frames cannot be used for shaped shutters.

## MADISON HYBRID Z FRAMES

Suitable for shutters installed to the outer edge of a window recess.

**PVC Classic Z Frame**  
40mm

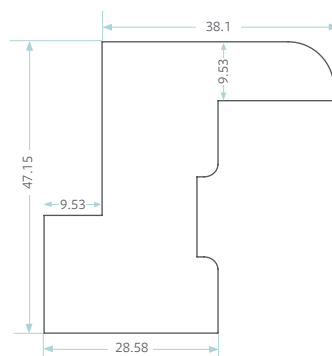

Trim

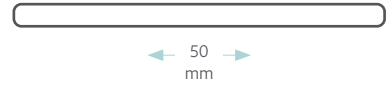

Light Block

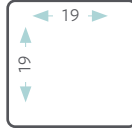

## 90° Triangular Batten

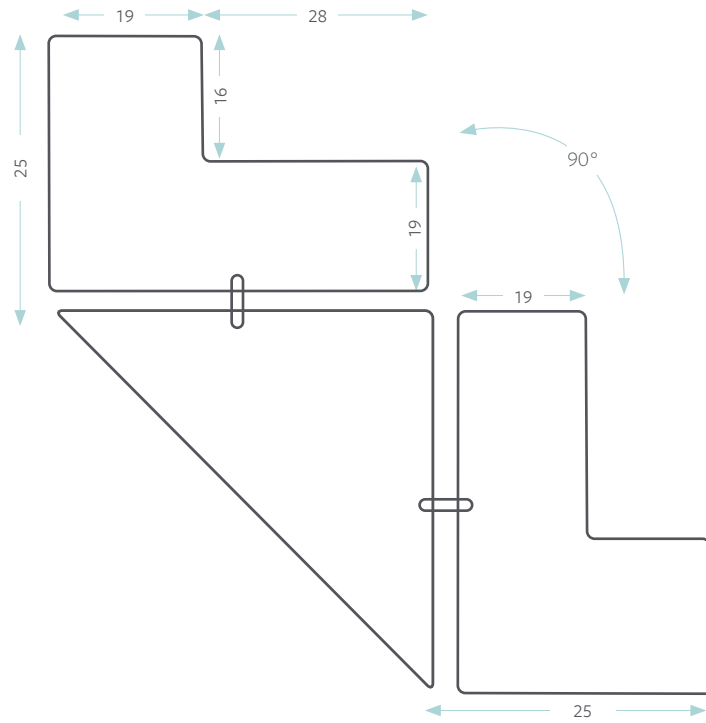

## 135° Triangular Batten

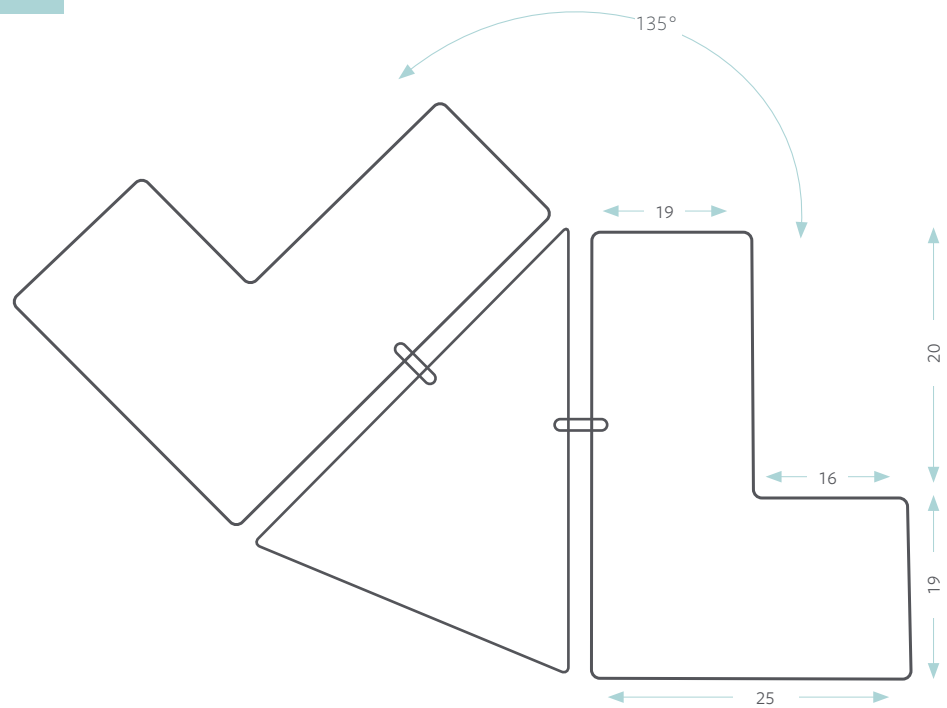

90° Bay Post

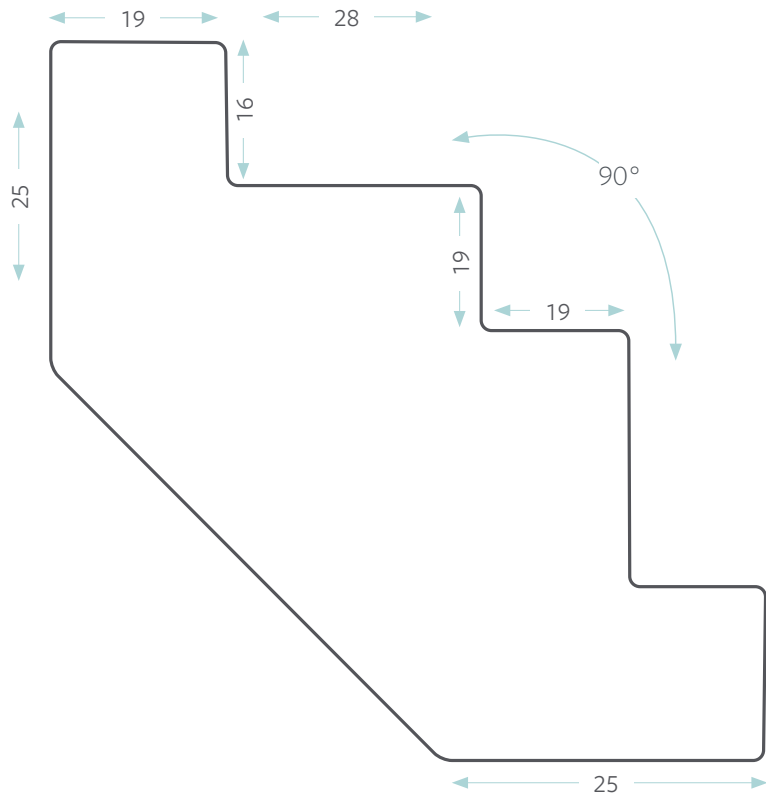

135° Bay Post

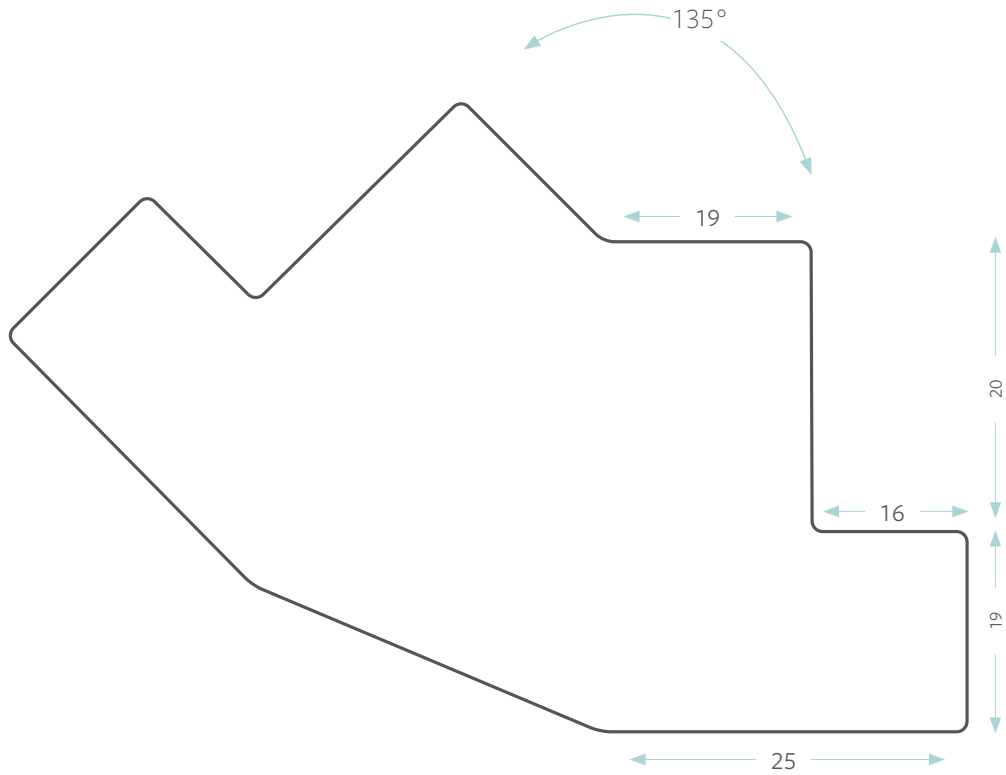

Please note: Custom bay posts available for Madison are available in degrees between 91 and 179.

# HARDWARE

## Hoffman Key

There are 2 x sizes of Hoffman Key: 27mm & 36mm. These are pre inserted into both mitred ends of the top and bottom frame pieces. This will allow for easy assembly of the frame prior to installation and will hold the mitre together.

## Hinges Colours

Natural White, Off White, Antique Brass, Brass, Black, Stainless Steel

COLOUR	DEFAULT HINGE COLOUR
Cloud	Natural White
Soft White	Natural White
Pure	Natural White
Cream	Natural White
Oyster	Off White
Grey	Off White
Stone	Stainless Steel
Taupe	Stainless Steel
Signal	Stainless Steel
Charcoal	Stainless Steel
Moss	Stainless Steel
Anthracite	Stainless Steel
Black	Black
Beach White	Off White
White Oak	Off White
Forest Grey	Stainless Steel
Aspen	Brass
Heritage Oak	Brass
Acacia	Antique Brass
Westbourne Oak	Antique Brass
Santos	Black
Sapele	Black
Parisian Oak	Black
American Walnut	Black
Matte Black	Black



HINGES	
Panel ≤1300mm	2 hinges
Panel 1301mm - 1800mm	3 hinges
Panel 1800mm - 2500mm	4 hinges
Panel 2501mm - 3000mm	5 hinges

## Hidden Hinge

Madison & Madison Hybrid shutters can be ordered with a stainless steel hidden hinge, which is concealed within the frame. Hidden Hinge cannot be used on Embassy Z frame, Regal Z frame, Regal Z frame with insert or blackout shutter.

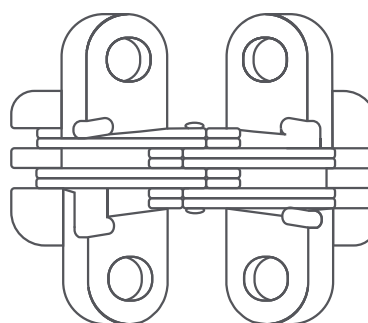

## Magnets

Shutters are supplied with small round magnets which are pre inserted into the back of the panel's stile. Frames receive a round magnet strike plate which is pre fitted to the frame. The colour will match the colour of the hinge.

# HARDWARE

## Shutter Finishes

### Painted Finish

Custom made shutters come in a variety of standard paint finishes. Please revert to the swatch for colours available.

### Custom Paint Finish

Custom colour option available for popular paint brands, Dulux, Farrow & Ball and Little Greene Paint Co.

## Handles for Solid Shutter Panels



Knob handles for the solid shutter panels will come in a metallic silver finish only which will be supplied in a hardware box for the fitter to install.

Knob handle length is 22.86mm.

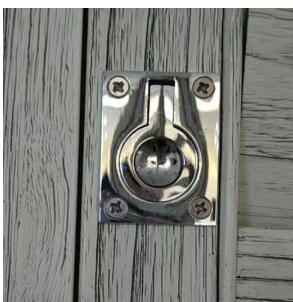

Pull ring or recess handle will also come in a metallic silver finish. The handle will come pre-assembled on the shutter unless specified in special instructions not to.

## Brushed Steel Sliding Bolt

Madison & Madison Hybrid shutters can be ordered with a sliding bolt to prevent the shutter from being opened from the outside. This is a recommended addition to shutters intended for Velux or angled windows. Bolt Locks are not available on shaped shutters or bypass shutters. Bolt will always be placed in the bottom of the shutter, on the opposite side of the hinge.

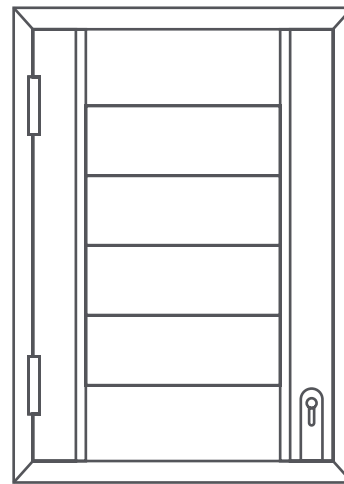

# STYLE PORTFOLIO

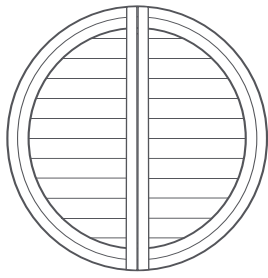

Circle 1

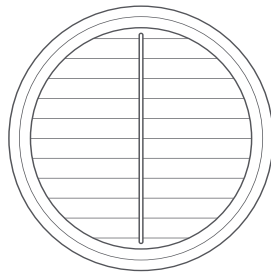

Circle 2

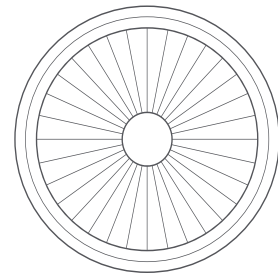

Circle 3

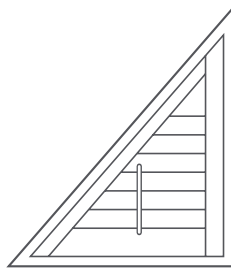

Triangle 2 Right

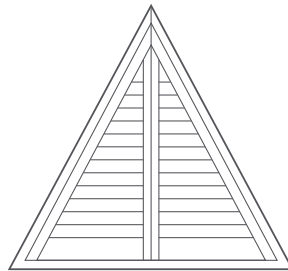

Triangle

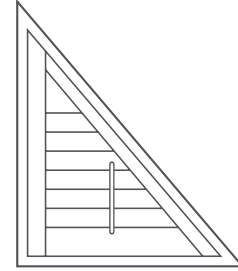

Triangle 2 Left

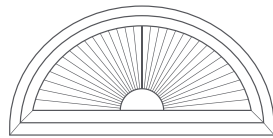

Sunburst 1

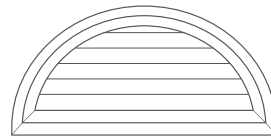

Sunburst 3

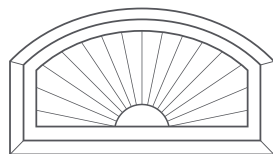

Elongated Sunburst 1

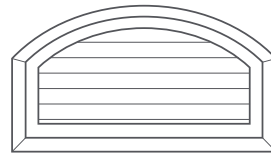

Elongated Sunburst 3

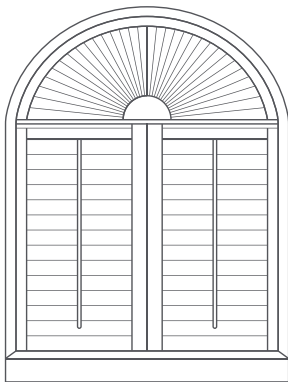

Arch 1

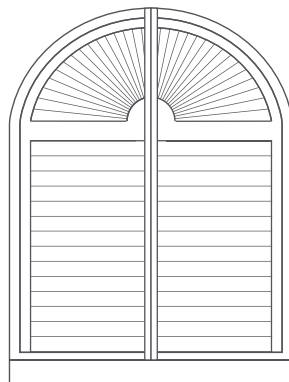

Arch 2

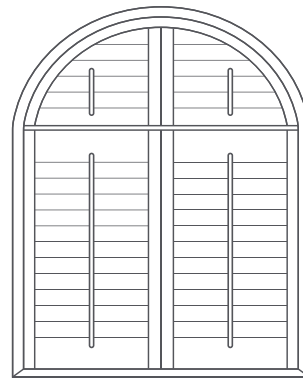

Arch 3

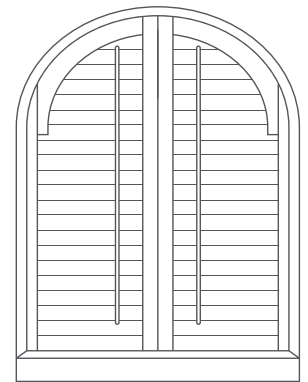

Arch 4

Please note: Cover strip frames cannot be ordered if the shape has a curve. Curved shaped shutters are not available with Plain L, Vintage L, Bullnose or Camber Deco frames.

# STYLE PORTFOLIO

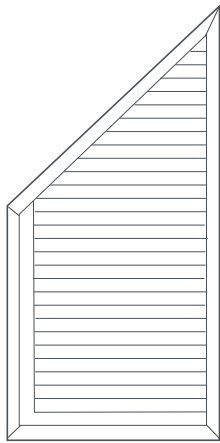

Tapered 1 Right

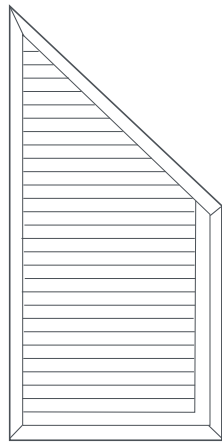

Tapered 1 Left

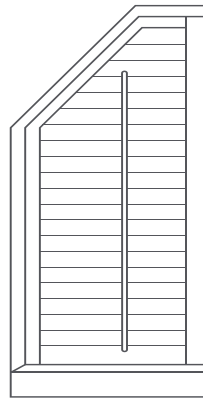

Tapered 2 Flat Top Right

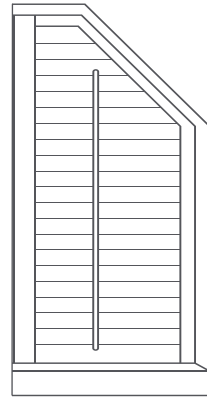

Tapered 2 Flat Top Left

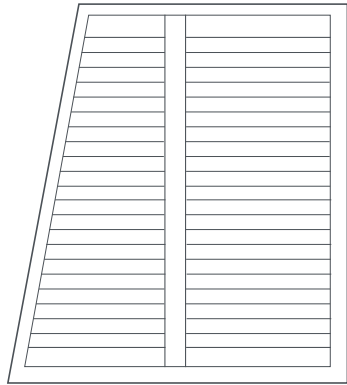

Trapezoid 2 Right

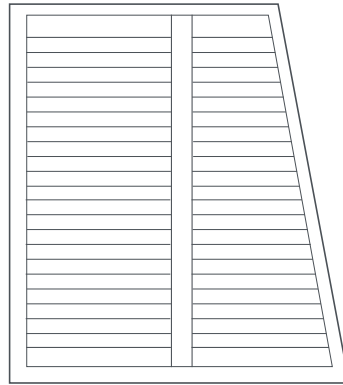

Trapezoid 2 Left

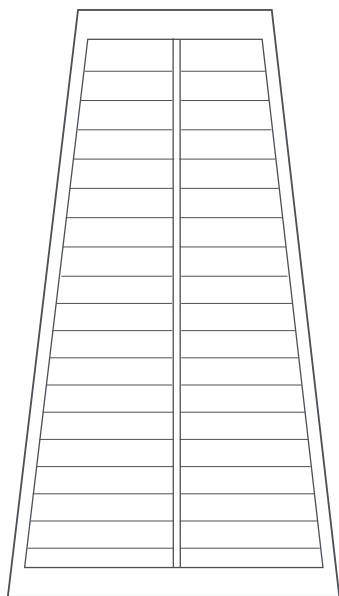

Trapezoid 1

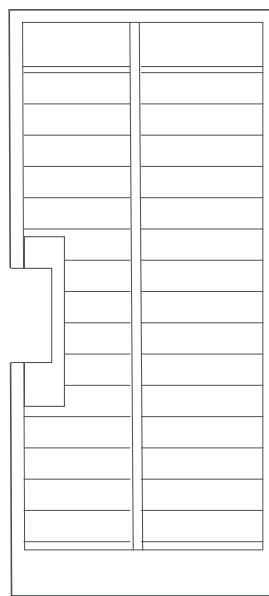

French Door Type C

## MEASURING FOR SHAPED SHUTTERS

Measure from the very centre of the width to the top of the shape. The measure the different heights at every 100mm out from the centre.

For accuracy, measure at 50mm at either end. A laser measure can be an effective tool during this type of survey.

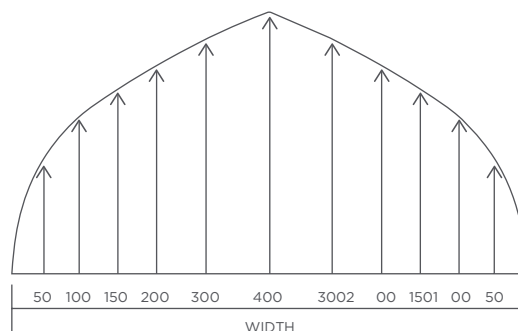

## BLOCKOUT SHUTTER

Blockout blind headrail and bottombar colour- White

Max size/opening for blackout blinds is 1600mm wide.

For sizes over 1600mm a T post is required. A blind will be installed in each opening.

Blind fabric used is a 25mm blockout cellular fabric. Available in white only.

The honeycomb design completely blocks out the light with each cell having an internal foil wrap, creating both light block out and thermal insulation. The insulating characteristics help keep the heat out in summer and the warmth in during winter.

114mm louvre not available with Blockout Shutter option. For all other louvre sizes, when tilting, ensure blockout blind is fully closed or fully open.

Blockout blinds will have a 4mm clearance across the width of the blind in relation to the shutter frame. Not available in Madison Hybrid.



SHUTTER SIZES	
Min Width	300mm
Max Width	1600mm
Max Width with T-Posts	3500mm
Min Height	300mm
Max Height	2000mm

4 x sided shutter frame is always required.

NO. OF BRACKETS PER WIDTH OF BLIND	
<700mm	4
701mm - 1000mm	6
1001mm - 1500mm	8
>1501mm	10

Numbers above show total number of brackets supplied with blind. Equal number of brackets are to be placed on top and on bottom of blind.

## BI-FOLD TRACKING SHUTTER

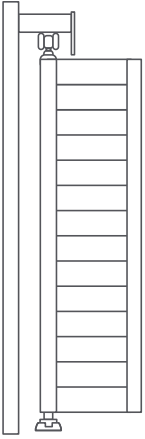

Bi-Fold Tracked Shutter is shutter panel where two or more panels are hinged together so they can be folded and slide to one side.

To avoid unforeseen problems, it is very important to provide the nett measurement of height and width of the window opening.

In the charts below, you will see how to measure the nett height and width for Bi-Fold Tracked Shutter.

## BI-FOLD TRACKING SHUTTER

### RECESSED BOTTOM TRACK WITH BOTTOM BOARD

The Bottom Track is recessed fully into bottom board.  
The bottom clearance is 27mm between the panel's bottom and the floor.

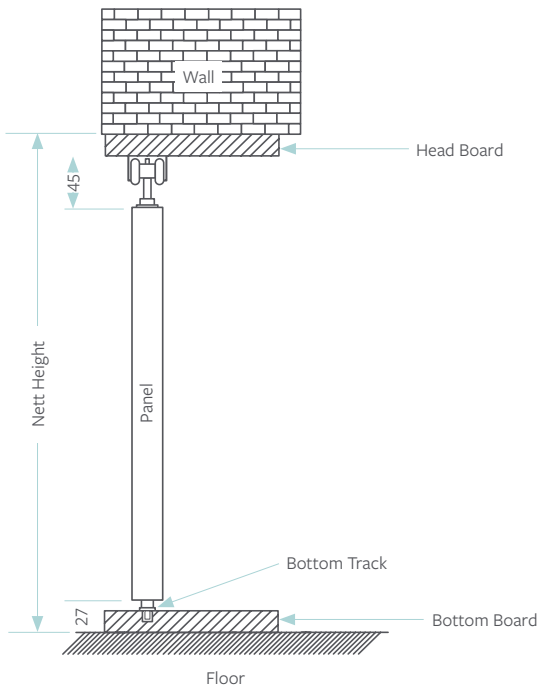

Inside Mount

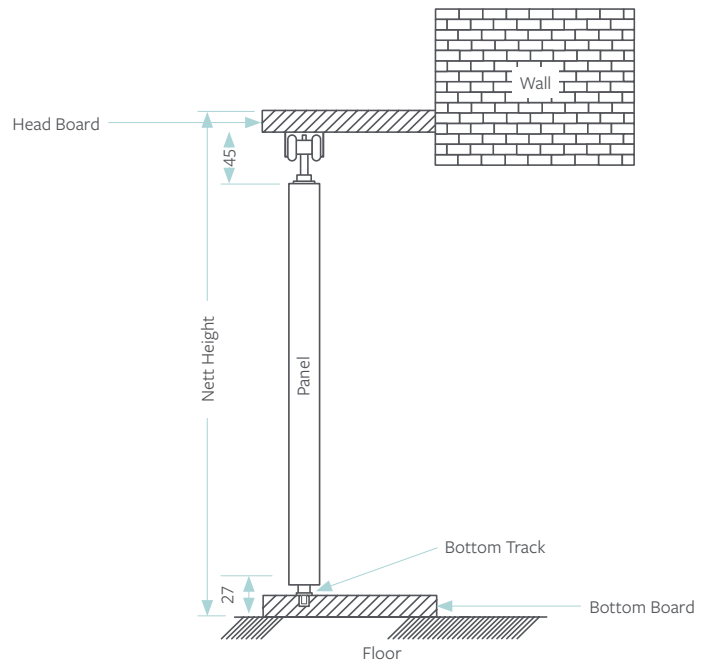

Outside Mount

# BI-FOLD TRACKING SHUTTER

## TOP TRACK POSITION

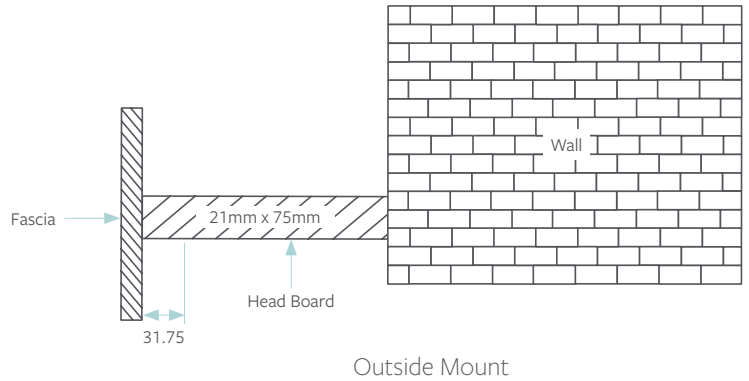
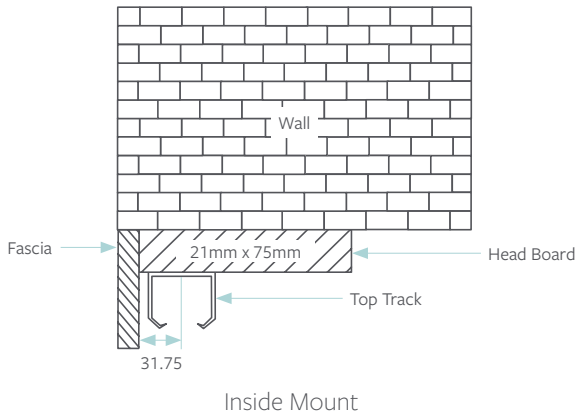

## BOTTOM TRACK POSITION

Recessed Bottom Track is recessed fully into the bottom board at 20mm from the edge of the bottom board to the centre of it.

If there's no bottom board, then the bottom track needs to be aligned with the top track and recessed into the floor manually.

For Recessed Bottom Track, we will supply screws as we don't recommend double adhesive tape.

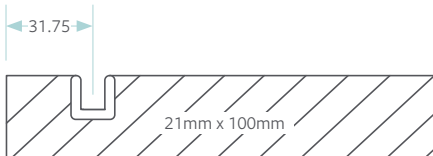

Recessed Bottom Tracks will be supplied in the same length as the bottom board, or same as the header if the bottom board is not used.

Recessed Bottom Track will be supplied loose.

## HEADER & SIDE FRAME

For Header length more than 4200mm (painted) and 2700mm (stains). We'll use 2 pieces of the same length components to join together with mitre and dowel.

The top track will be pre-assembled onto the header.

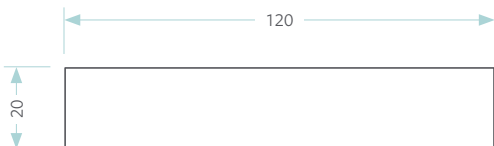

# BI-FOLD TRACKING SHUTTER

## LIGHT BLOCK

30mm x 12mm for light block.

We will supply the mounting block for both inside and outside mount in the same length with header and side frame

## SIDE BOARD



Side Fascia is supplied loose in the same length as the side frame.

## TOP FASCIA & TOP FASCIA RETURNS

Top Fascia is supplied with returns for both inside and outside mounts and cut at 45°. The total length of the top fascia is the length of header + 20mm.

The length of Top Fascia returns is the width of the header (100mm)+10mm.

Please specify the width of top fascia i.e. 54mm for inside mount or 100mm for outside mount.

If the length of top fascia is more than 3810mm, it will be split into three pieces with the length of left and right pieces are shorter than the centre piece.

Both top fascia and top fascia returns are supplied loose. The mounting block is also supplied loose.

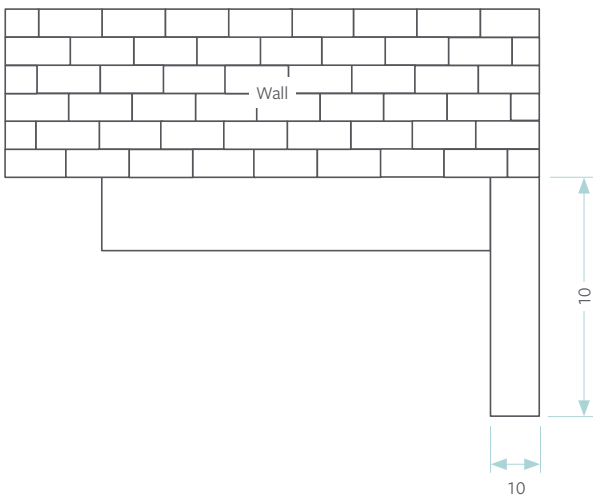

Inside Mount

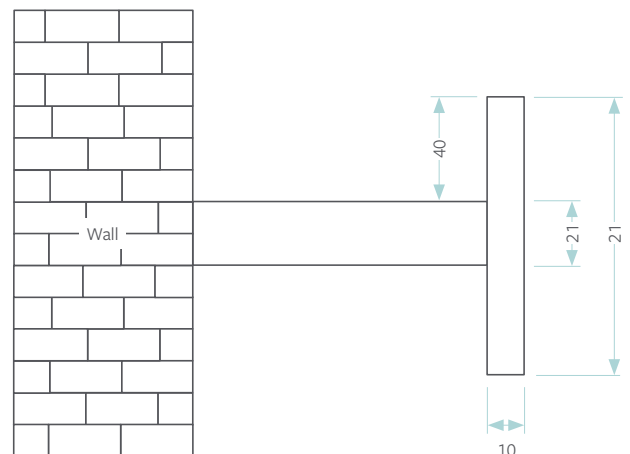

Outside Mount

# BI-FOLD TRACKING SHUTTER

## NETT WIDTH MEASUREMENT FOR BI-FOLD TRACKED SHUTTER

To avoid unforeseen problems, it is very important to provide the nett measurements of height and width of the window opening.

As the nett height measurement is already described above (with/without bottom board, in/outside mount), the following chart shows how to measure the nett width.

Please note that there is a 8mm gap between the panel and the side frame, it is the clearance needed for the panel to turn when it is being folded.

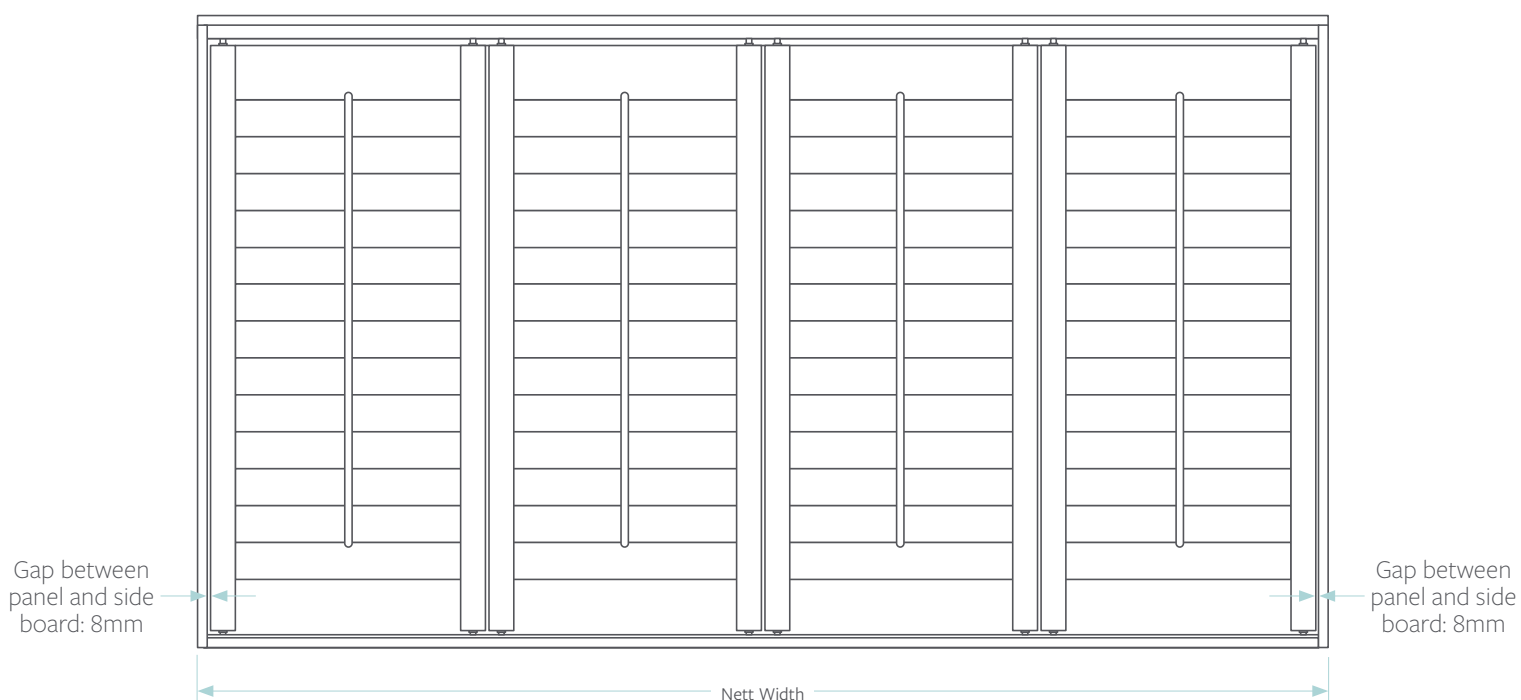

## BYPASS TRACKING SHUTTER

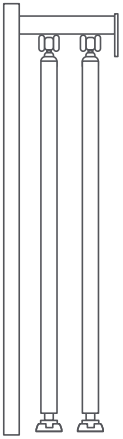

ByPass Tracked Shutter is shutter panels that can slide effortlessly across a discreet track system.

To avoid unforeseen problems, it is very important to provide the nett measurement of height and width of the window opening.

In the charts below, you will see how to measure the nett height and width for ByPass Tracked Shutter.

Please note: On ByPass shutters, slats must be fully closed before sliding.

## BYPASS TRACKING SHUTTER

### RECESSED BOTTOM TRACK WITH BOTTOM BOARD

The Bottom Track is recessed fully into bottom board.  
The bottom clearance is 27mm between the panel's bottom and the floor.

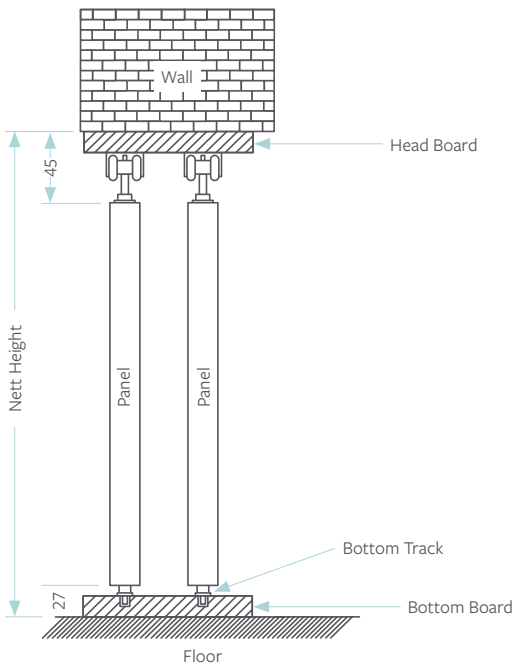

Inside Mount

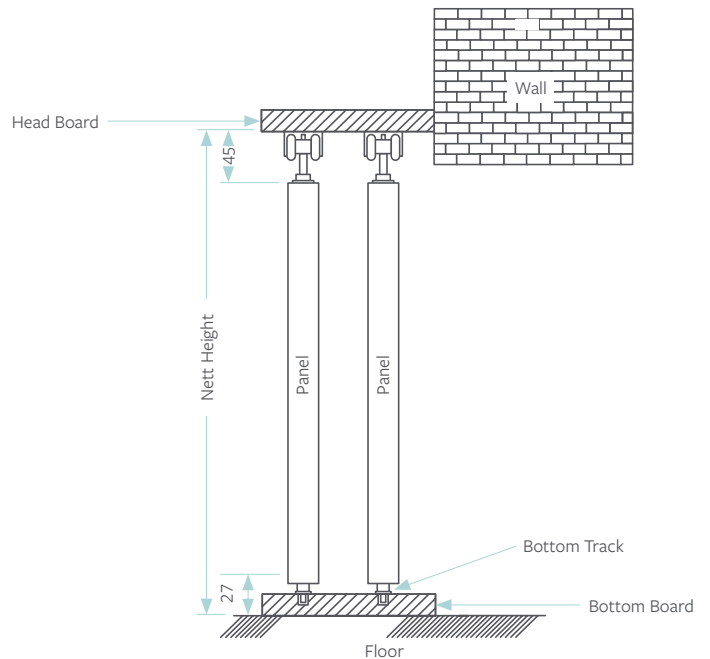

Outside Mount

# BYPASS TRACKING SHUTTER

## TOP TRACK POSITION

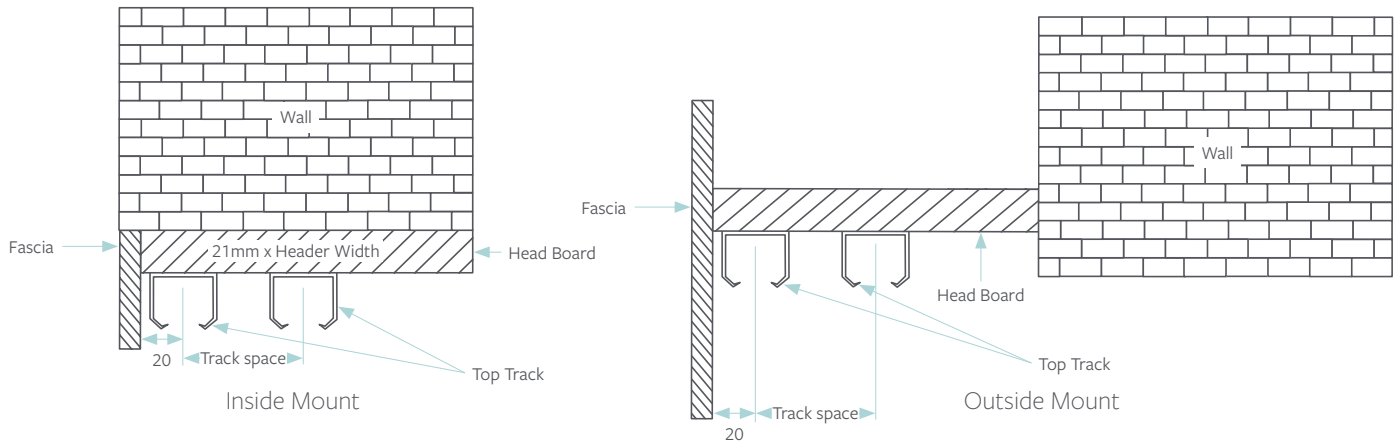

## HEADER & SIDE FRAME

The thickness of Header and Side Frames are 20mm. The width of Header and Side frame are explained on the below chart. For header length more than 4200mm (painted) and 2700mm (stains), we will use 2 pieces of the same length components to join together with mitre and dowel.

The top track will be pre-assembled onto the header.

# BYPASS TRACKING SHUTTER

## BOTTOM TRACK POSITION

Recessed Bottom Track is recessed fully into bottom board at 20mm from the edge of bottom board to the centre of it.

If there's no bottom board, then the bottom track needs to be aligned with the top track and recessed into the floor manually.

For Recessed Bottom Track, we will supply screws as we don't recommend double adhesive tape.

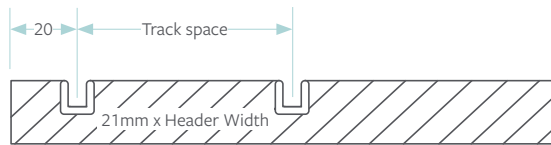

The Track Space on bottom track is the same as the one on the top track.

Both Raised and Recessed Bottom Tracks will be supplied in the same length as the bottom board, or same as the header if the bottom is not used.

Both Raised and Recessed Bottom Track will be supplied loose.

## LIGHT BLOCK

30mm x 12mm for light block

## SIDE BOARD



Side Fascia is supplied loose in the same length as the side frame.

# BYPASS TRACKING SHUTTER

## TOP FASCIA & TOP FASCIA RETURNS

Top Fascia is supplied with returns for both inside and outside mounts and cut at 45°. The total length of the top fascia is the length of header + 20mm.

The length of Top Fascia returns is the width of the header (100mm)+10mm.

Please specify the width of top fascia i.e. 100mm for inside mount or 140mm for outside mount.

If the length of top fascia is more than 3810mm, it will be split into three pieces with the length of left and right pieces are shorter than the centre piece.

Both top fascia and bottom fascia returns are supplied loose.

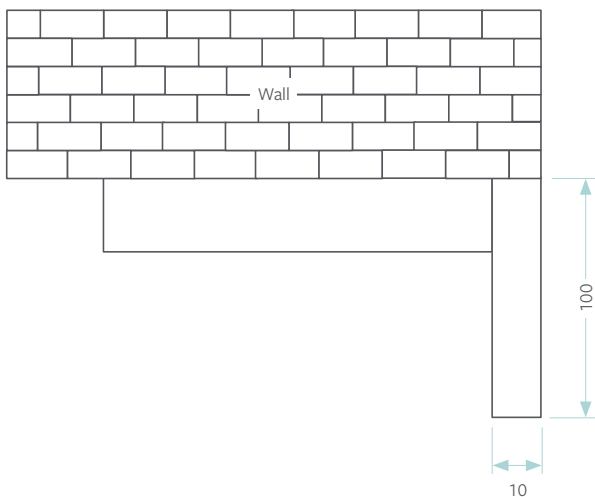

Inside Mount

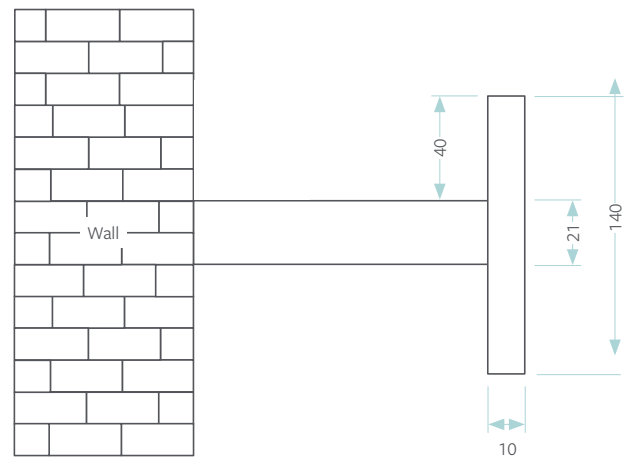

Outside Mount

# TERMS & CONDITIONS

## 1. Buyer/Seller

- 1.1 In these conditions “the Seller” means Santa Fe Shutters and “The Buyer” means the person, firm or company placing an order for goods or services, which are subject to these terms and conditions which are not variable except in writing signed by the Seller.
- 1.2 These conditions of sale together with the particulars contained in the order acceptance save where stated otherwise and any special conditions agreed by the Seller in writing constitute the entire contract between the Buyer and the Seller.
- 1.3 Periods of time referred to in these conditions of sale shall be of the essence.

## 2. Quotation

- 2.1 All quotations by the Seller represent an invitation to the Buyer to place an order and do not constitute a legal offer. The purchase order will be regarded as the offer and the Seller’s order acceptance will be regarded as binding. No alternative terms and conditions will be considered or accepted by the Seller.
- 2.2 All prices are quoted without commitment and are subject to alteration or withdrawal by the Seller without prior notice. Orders can be accepted on the condition that the prices charged are those ruling at the date of order unless the Seller specifically agrees in writing to engage a fixed price contract.

## 3. Delivery

- 3.1 Delivery times are estimates only and not of the essence. Whilst every effort is made to ensure due performance, the Seller cannot accept responsibility for damages or consequential loss or damage arising out of delay or failure to deliver by the specified date.
- 3.2 If a Buyer fails to take delivery of the goods or any part of them on the due date for any reason whatsoever the Seller will be entitled to charge for re-delivery and upon notice to the Buyer delivery will be deemed to have taken place and the Buyer will pay to the Seller all costs and expenses including storage and insurance charges. Any delay or failure to deliver by the Seller will not entitle the Buyer to refuse delivery or to repudiate the contract and the full price will be payable to the Seller without deduction.
- 3.3 Non delivery or damage pilferage in transit must be reported in writing to the Seller within 5 days of receipt of invoice or advice of despatch. Where goods are collected from the Seller by the Buyer or a third party nominated by the Buyer the risk in goods passes to the Buyer upon delivery to the Buyer or such third party. Thereupon liability of the Seller in the goods for loss or deduction, breakages, shortages or non delivery shall cease.
- 3.4 The address for delivery shall be the Buyer’s address as stated on the order unless otherwise stated between the parties in writing.
- 3.5 Once the goods are delivered and signed for either in good condition or unchecked, the Seller cannot accept responsibility for any damage to said property.

## 4. Retention of Title

- 4.1 The goods shall remain the property of the Seller until full payment has been received (each order being considered as whole).
- 4.2 The Buyers right to possession of the goods will cease at the earliest of the following date:
  - 4.2.1 On expiration of any agreed period of credit, or due date for payment of any invoice has passed.
  - 4.2.2 If being an individual he commits an act of bankruptcy or makes a proposal to his creditors or does anything which would entitle a petition for a bankruptcy order to be made, or the Seller believes on reasonable grounds that the same is likely to occur.
  - 4.2.3 If being a company it goes into liquidation or does anything or fails to do anything which would entitle a receiver to take possession of any assets or which would entitle any person to present a petition for winding up or to apply for an Administration order, or the Seller believes on reasonable grounds that the same is likely to occur.  
The Seller will have the right if paragraphs 4.1 applies:
    - To repossess the goods
    - To use or sell all or any of the goods
    - To enter any premises of the Buyer, for the aforesaid purposes

## 7. Payment Terms

- 7.1 Payment terms apply. A deposit of 50% of the total cost must be paid to Santa Fe Shutters at the time of placing the order. This is non-refundable. The remainder of the payment must be made in full on final installation of the shutters.

# TERMS & CONDITIONS

7.3 Credit facilities are available on request. Terms and conditions of the credit provider will apply.

## 8. Returns

8.1 Any defective good must be notified within 5 days of being delivered/installed. Goods delivered and signed for in “perfect condition” cannot be returned.

## 9. Liability

- 9.1 All goods should be carefully inspected prior to installation. The Buyer must check that the shutters, the frames and ancillary fittings including operation method are in accordance with the purchase order both for colour and design prior to installation. The Seller cannot accept any responsibility in circumstances where the Buyer is not present at the delivery/ installation address.
- 9.2 The Buyer must check that shutters are to colour sample prior to installation. The Seller cannot guarantee precise colour matching against samples; most of our products are made from natural materials. Minor imperfections not readily apparent at a distance of 1000mm under ordinary light will not be accepted as defects. Colour matching of finishing products e.g. paint, cannot be guaranteed although every reasonable effort will be made to ensure the accuracy of the finished product.
- 9.3 The Seller cannot guarantee the goods against fading or darkening especially as a result of exposure to sunlight where fading or darkening may occur. Santa Fe Shutters are not guaranteed against extreme damp, warm or variable conditions.
- 9.4 The Seller reserves the right to withdraw any products and colours at any time without prior notice and cannot be held responsible for any consequences, caused by the withdrawal of such products.
- 9.5 Under no circumstances, except in respect of death or personal injury caused by the Sellers negligence does the Seller accept liability for consequential loss, damage or costs or expenses, howsoever arising and any liability for any such consequential loss is hereby specifically excluded. Should a claim be made the Sellers liability is limited to the value of the order placed by the Buyer.
- 9.6 The Seller gives no warranty as to the fitness of the product supplied for any other purpose other than that of an internal window dressing as surveyed by the company; other installation and uses are the risk of the Buyer.
- 9.7 Tolerance levels of overall panel specifications are plus or minus 1mm, and the product will not be considered defective if falling within the size range. Warp on any component part, vertical or horizontal, shall not exceed 2mm per lineal metre and shall not be considered defective if within this tolerance.
- 9.8 Limitations. It is recommended that panels be ordered within our normal size range. For example, panels above 1700mm in height are ordered with a mid rail, and that panel widths do not exceed 600mm for faux wood shutters. We may exceed the limitation at your request, but in doing so we cannot accept responsibility for any problems that result.
- 9.9 If the Buyer is not on site when property is surveyed or installed the shutters will be fitted in accordance to our standard practices unless agreed prior to confirmation. If the Buyer chooses to install against our recommendation then liability will be theirs.
- 9.10 Upon installation the Seller shall not be responsible for the moving or the relocation of any electrical wiring which may be obstructing any installation process. It is the responsibility of the Buyer to relocate any electrical wiring and leave a clear opening before installation can proceed.
- 9.11 The Seller shall order in accordance with the Buyer’s Order Acceptance. As soon as the Seller has placed the Buyer’s order, Order Acceptance shall become binding in the Buyer’s choice of product, design option, colour etc. Any alteration that the Buyer wishes to make will incur the re-ordering and therefore shall be at the expense of the buyer.
- 9.12 If installers are paid by the Buyer the Seller cannot except liability for any damage or defective installation.. The foregoing is in substitution for all other terms, express or implied relating to the quality or fitness for purpose, and all such terms are hereby excluded. This does not, however, affect the consumer’s statutory rights.

For full terms and conditions please visit: [www.santafeshutters.co.uk/terms](http://www.santafeshutters.co.uk/terms)