

Installation Manual
Silver Compact Freestanding

Dear Customer,

Installation manual contains suggestions and rules for fast and exact installation of our product. We recommend you to read our instruction carefully.

During installation, all necessary actions have to be carried out by authorized and specialized technicians.

All unauthorized interventions during warranty period will invalidate the warranty.

INDEX

1. Symbols, Precautions and Warnings	04
2. Terminology	05
3. Packaging	06
4. Installation Steps	11
5. Programming / Resetting of Panels and Lights	49
6. Sensors and Automation	60
7. Hardware	70
8. Tools	77
9. Frequently Asked Questions	81
10. Risk Table	82
11. Motorization	83

1. SYMBOLS, PRECAUTIONS AND WARNINGS

1.1. Symbols



Attention: General operation notes.



Attention: General hazards; possible risk for persons.



Attention: Electrical hazard.



Attention: Risk of crushing hands.



Contact: Palmiye service department or related parties.



You can scan the barcodes located at the bottom of the page to see video demonstration of the related steps.

1.2. Precautions and Warnings

The installation and maintenance personnel (installers, electricians etc.) must have sufficient expertise and knowledge for undertaking the task at hand.

In case of anomalies, immediately stop the work and contact with hospital.



Palmiye will not be responsible on use of non-original parts or unauthorized interventions and modifications for damage caused to people or animals or property.

General Precautions

Before starting of any assembly, maintenance or cleaning operations, make sure that you have fully understood the indications in this manual.

All electrical connections for the product, installation of automation accessories must be made by qualified personnel.

The dealer will provide the necessary fittings for the wall and floor.



In case of any incompatibility, call Palmiye.

General Safety Precautions

It is good practice to remember that all moving parts can be a source of danger.



Make sure that power supply is cut off during maintenance.

It is recommended never to intervene on moving parts and to ensure that no operator is near to the moveable parts/control unit box before reactivating it after a technical or maintenance intervention.

2. TERMINOLOGY

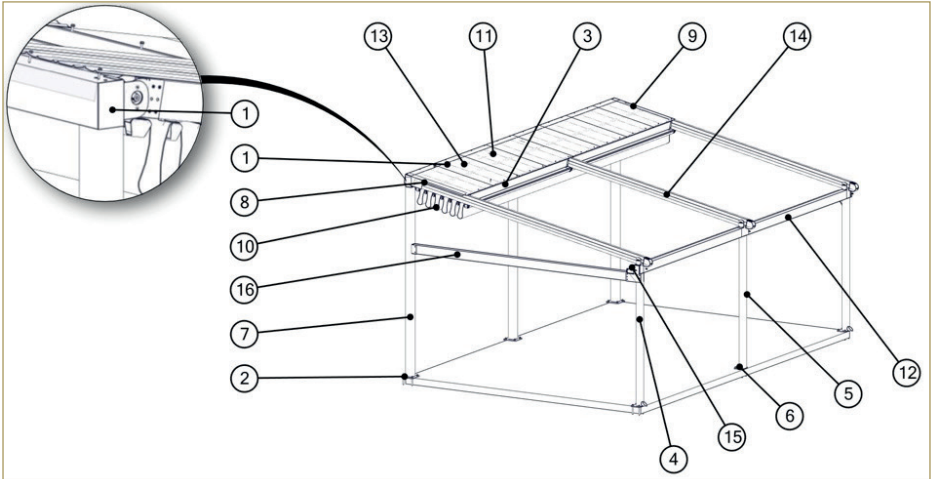

BOM ID	Description	Qty
1	Back Beam - Al. 100x150mm	1
2	Aluminium Flange 200x200x10mm	3
3	Cross Beam - Al. 40x120mm	4
4	Front Pillar - Al. 80x80mm (w/Drainage)	2
5	Front Pillar - Al. 80x80mm (w/o Drainage)	1
6	Aluminium Flange 150x150x10mm	3
7	Back Pillar - Al. 100x100mm	3
8	Cover Side Structure - Compact Left	1
9	Cover Side Structure - Compact Right	1
10	Fabric	1
11	Fabric Cover - Al. 63x100mm	8
12	Front Beam - Al. 80x130mm	1
13	Motor	1
14	Rail Profile - Compact (75x120mm)	3
15	Rain Gutter	1
16	Side Beam - Al. 80x130mm	1

3. PACKAGING

3.1. Preliminary Checks

On receipt of the packed goods and before starting their assembly, check the integrity of the material and the presence of all the components necessary for the installation.



In case of anomalies, immediately stop the work and contact with hospital.



Fixing elements such as screws, plugs etc. are included in the box.



If not please contact service department of Palmiye.



Do not use a knife to avoid the risk of ruining the paint or other materials.

3.2. Packed Parts

3.2.1. Back Beam

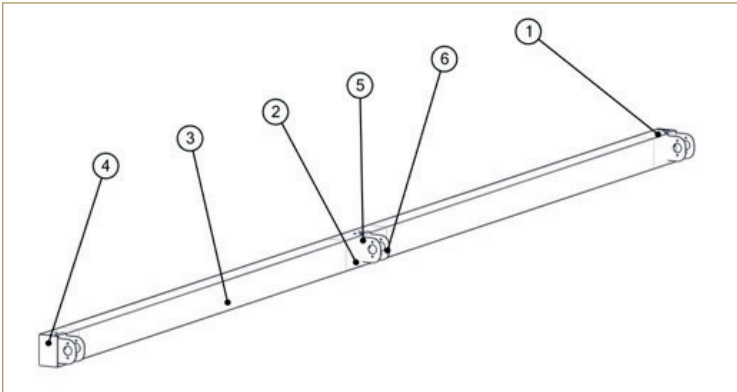

BOM ID	Description	Qty
1	100x150 Profile Support 200mm	2
2	100x150 Profile Support 400mm	1
3	100x150 Aluminium Profile	1
4	100x150 Side Cap	2
5	4,8x25 Self Tapping Screw	18
6	Rear Beam Rail Connecting Apparatus - Compact	3

3.2.2. Rail

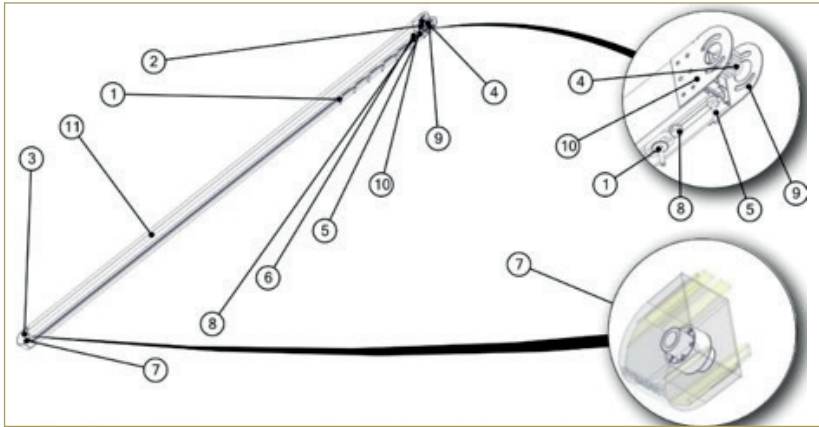

BOM ID	Description	Qty
1	4 Wheel Carriage	6
2	M4, 8x25mm Self-Drilling Screw	4
3	Rail Front Cap Rounded	1
4	Rear Roll Bearing Set	1
5	Fixed Carrier	1
6	Square Nut	1
7	Front Roll Bearing Set	1
8	M8x16mm Hexagonal Head Bolt	1
9	Rail Connection Support Left	1
10	Rail Connection Support Right	1
11	Rail Profile - 75x120mm	1

3.2.3. Front Beam

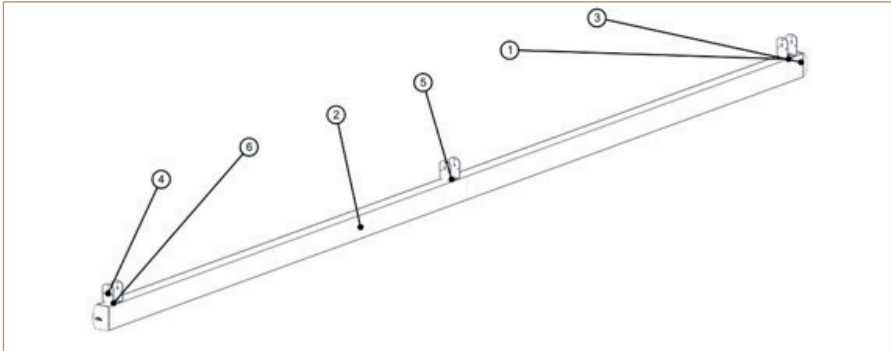

BOM ID	Description	Qty
1	4,8x25 Self Tapping Screw	6
2	Front Beam Aluminium Profile 80x130	1
3	Front Beam Cast Aluminium Cap - Rounded	2
4	Front Beam - Rail Connecting Bracket (77mm)	3
5	Support Profile 2x124x74 200mm	1
6	Support Profile 2x124x74 100mm	2

3.2.4. Front Pillar

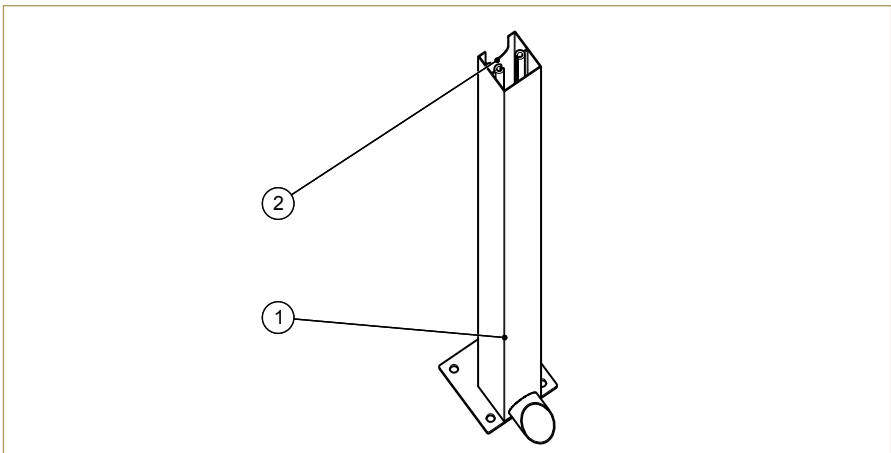

BOM ID	Description	Qty
1	150x150x10mm Aluminium Flange	1
2	80x80mm Aluminium Profile	1

3.2.5. Back Pillar

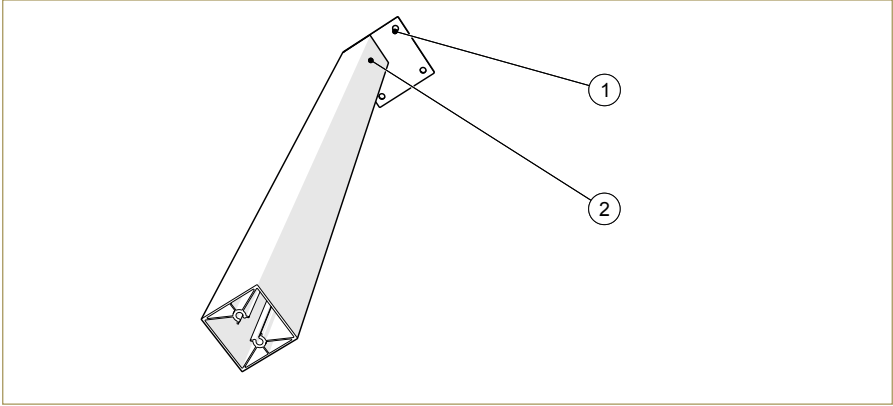

BOM ID	Description	Qty
1	200x200x10mm Aluminium Flange	1
2	100x100mm Aluminium Pillar w/o drainage	1

3.2.6. Side Beam (Standard)

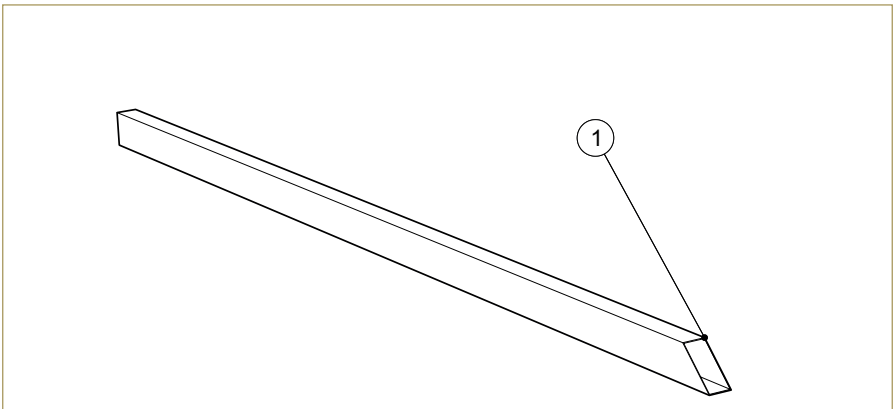

BOM ID	Description	Qty
1	80x130mm Aluminium Profile	1

3.2.7. Boxes

1. Electrical Box

Electrical Equipments - Lighting box, Synchronized control box, Remote Controls, Sensors - are inside Electric box. It has a red label on the box.



ELECTRIC

2. Metal Box

U Brackets, Mounting brackets, Gutter caps, Front beam and Rail connecting bracket caps, Hexagonal motor shaft drives, M12x185mm countersunk dacromented bolt, M10x160mm hexagonal dacromented bolt, M4,8x25mm self-drilling screws, M5,5x25mm self-drilling with sealant washer screws, drainage elbow, Stainless steel anchorages, (If you have a decorative fabric: M5,5x45mm philips screw, M5,5x70mm philips screw) are inside the Metal Box. It has a blue label on the box.



METAL

3. Plastic Box

Spot LED, Rubber for gutter, Fabric support profile plastics and its caps, motor shaft drive transmitter are inside the Plastic Box. It has a yellow label on the box.



PLASTIC

4. INSTALLATION STEPS



4.1. Structure Installation

4.1.1. Back beam and Back Pillar Installation

Back beam and back pillar should be connected by M12x185mm dacromented rod on ground.

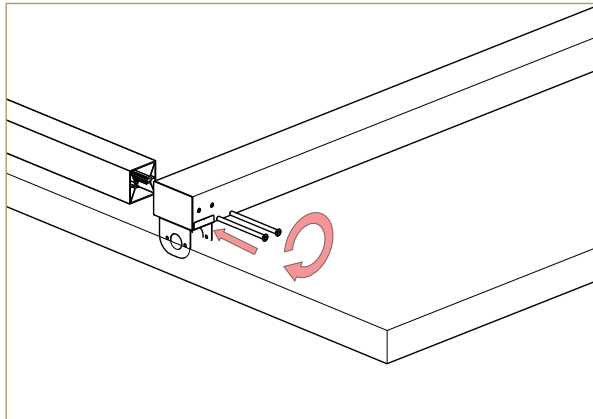
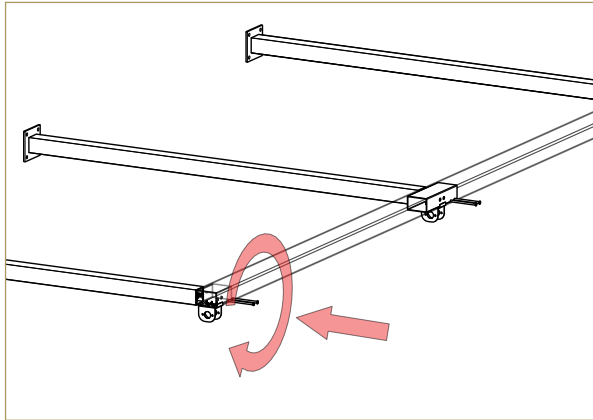

Don't work alone. You may need someone else while placing of the back profile.

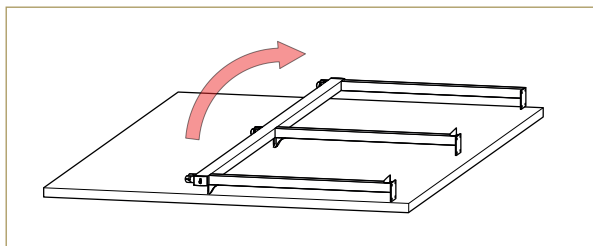



4.1.2. Front Beam and Front Pillar Connection

In order to prevent water leakage, you should apply a sealant to the connection points between the drainage-able elbow and front pillar. Place elbow to the pillar. The drainage elbow should face inward.

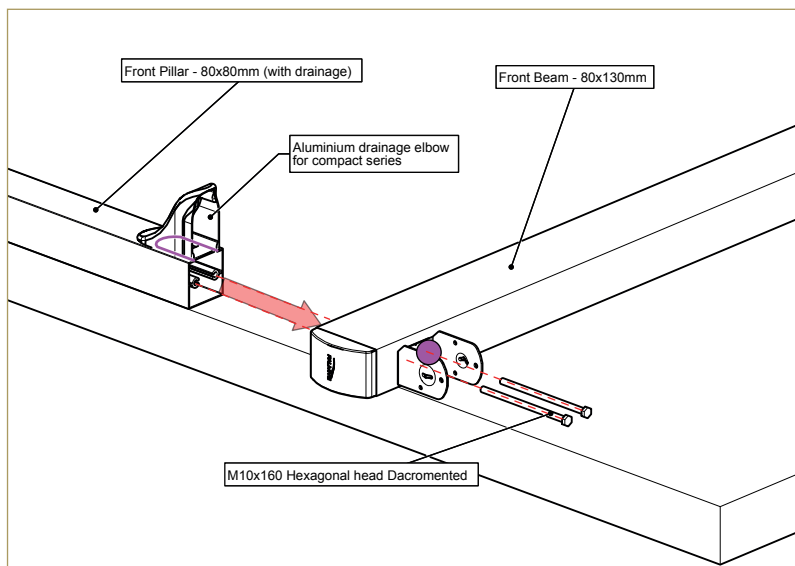
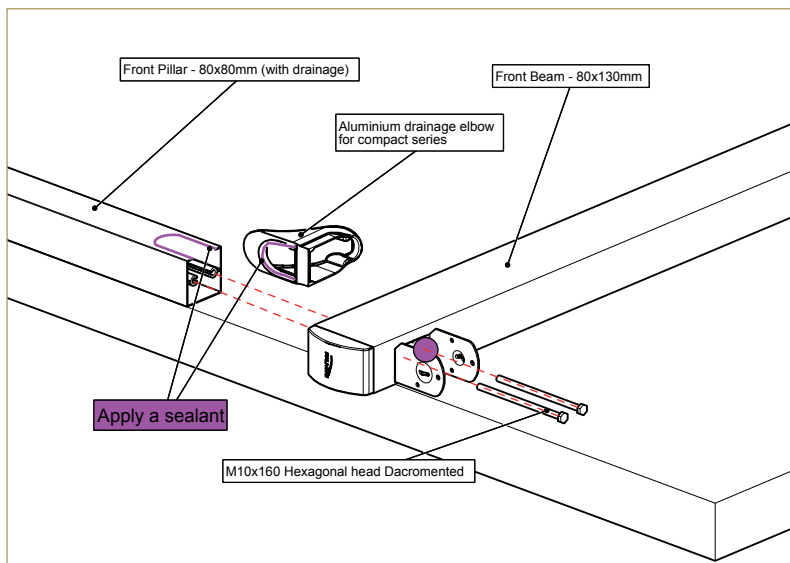

Front beam and front pillar connection screws should be fastened on ground after that you are able to lift as you shown image at below.

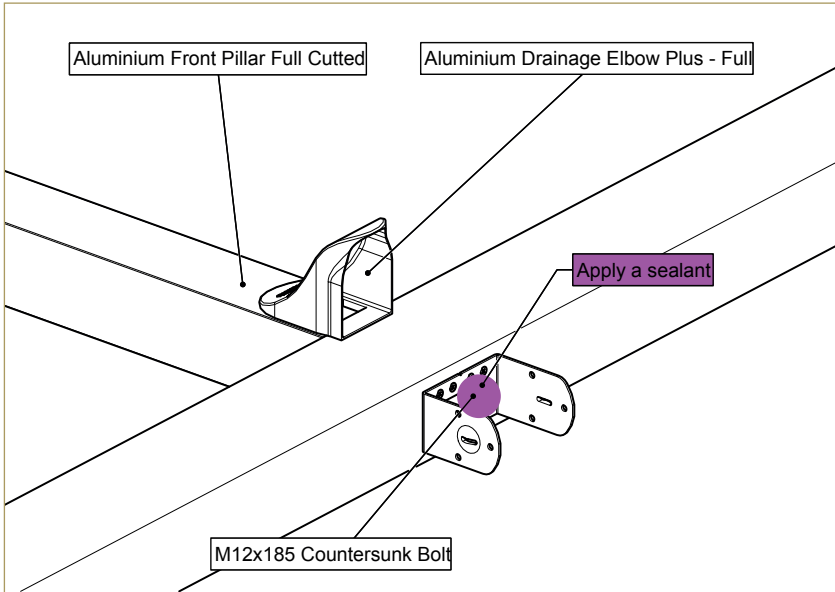

In this situation you may need some people since you must hold pillars carefully.

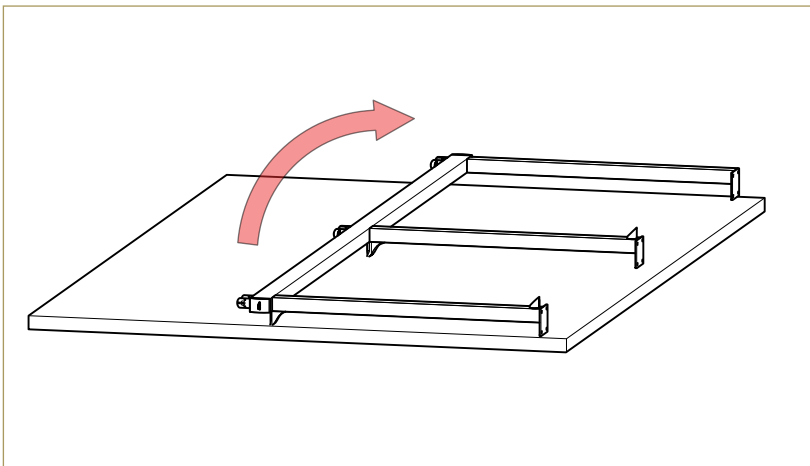

4.1.3. Hidden Side Beam Fixing

If you have preferred a hidden side beam connection, follow the steps below. Skip this section if you have selected a standard side beam connection.

Fix the apparatus to the wall/pillar with 6.5x50mm self-tapping screws and chemical dowel.

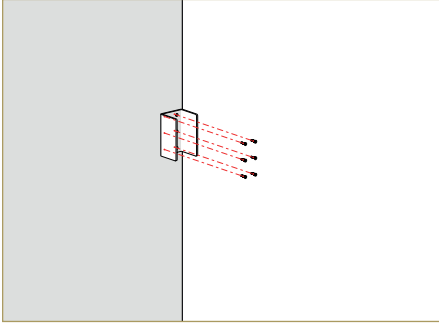

Pass the profile into the fixed apparatus.

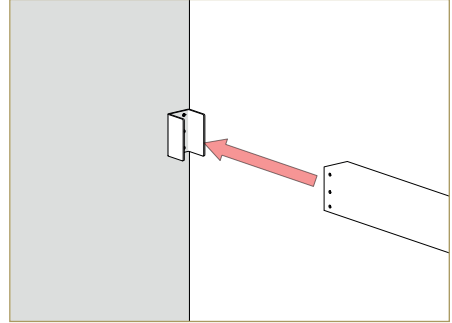

Fix the profile to the bracket with 3 4.8x25mm self-tapping screws from both sides.

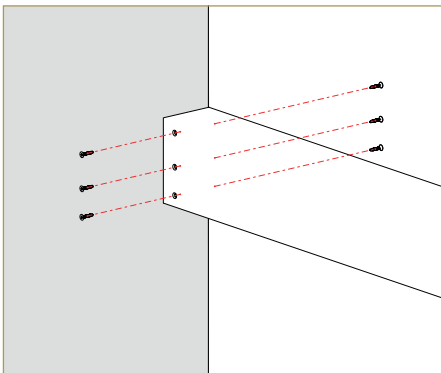

The profile is aligned on the front beam as follows;

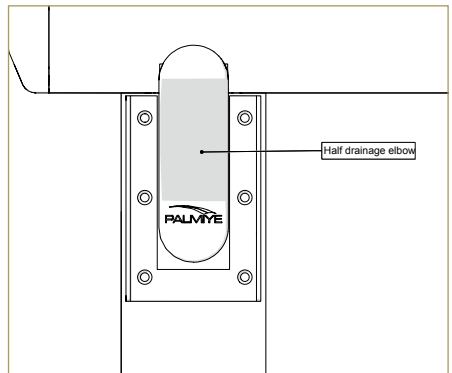

On the other side; if there is a drainage point, the U apparatus comes in as a ridge and in half drainage.

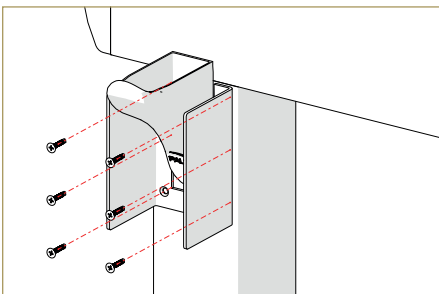

Fix the apparatus to the front beam with 6 pieces of 4.8x25 mm self-tapping screws.

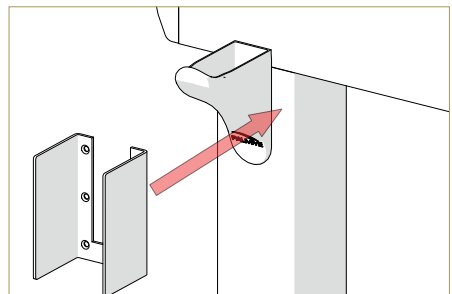

Attach the profile so that it passes over the fixed apparatus.

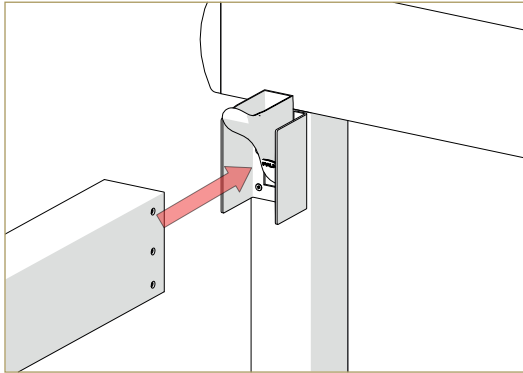

Fix it with 3 pieces of 4.8x25 mm self-tapping screws from the right and left sides.

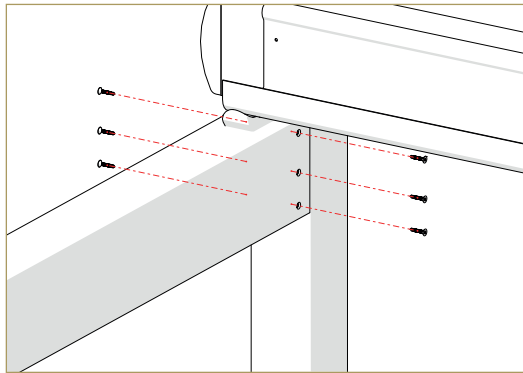

The version of the apparatus fixed to the profile is as follows.

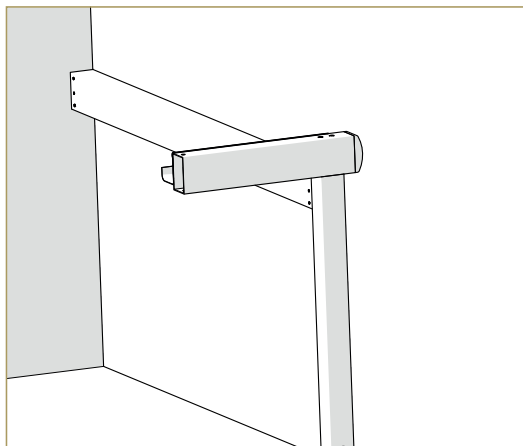



4.1.4. Rail Placing

There are two type rails. One of them without gasket and another one with gasket which located bottom of the rail and according to rail position. When you looking in front of the product the gasket must be inside of the product as you see at below picture.

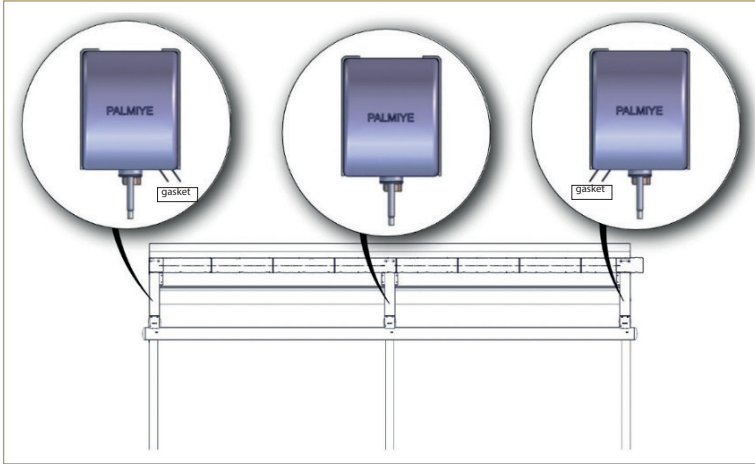

During rail bolts fastening to back beam and front beam you will need someone else according to rail weight and length dimension.

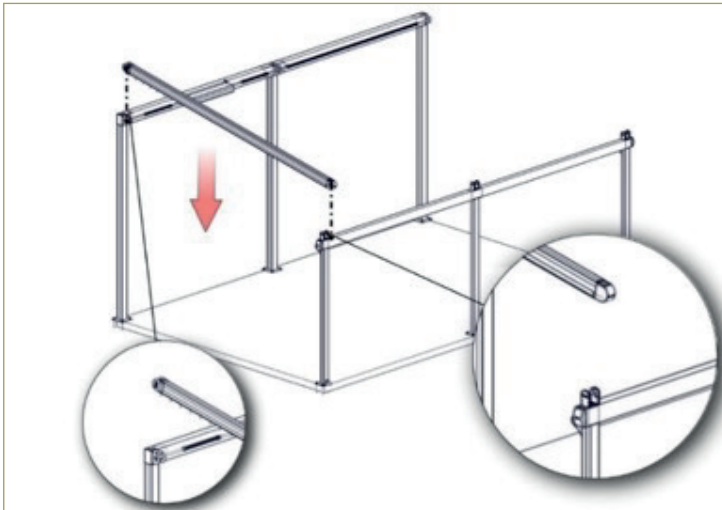

The rails are mounted to the rail brackets on the back beam with the help of 4 M8X20 bolts.

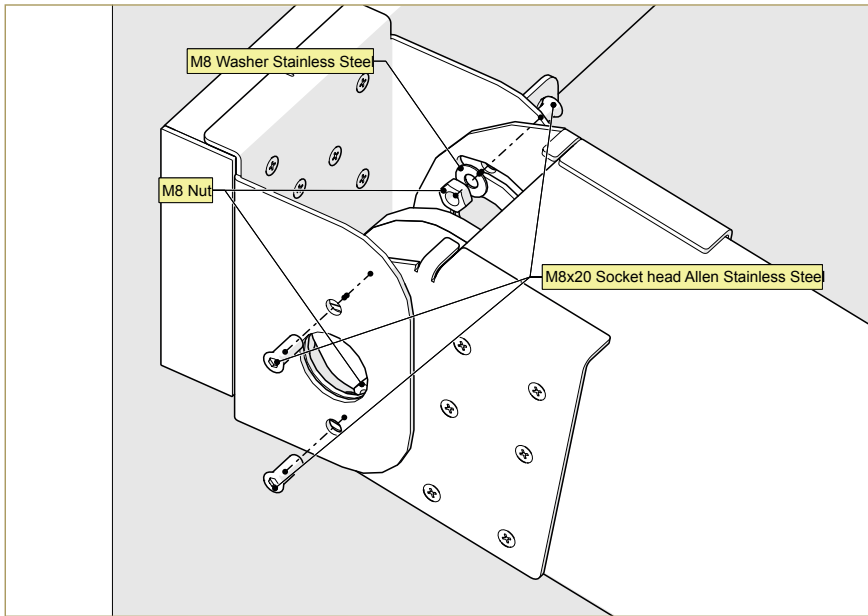

⚠ Shaft holes must overlap one to one.

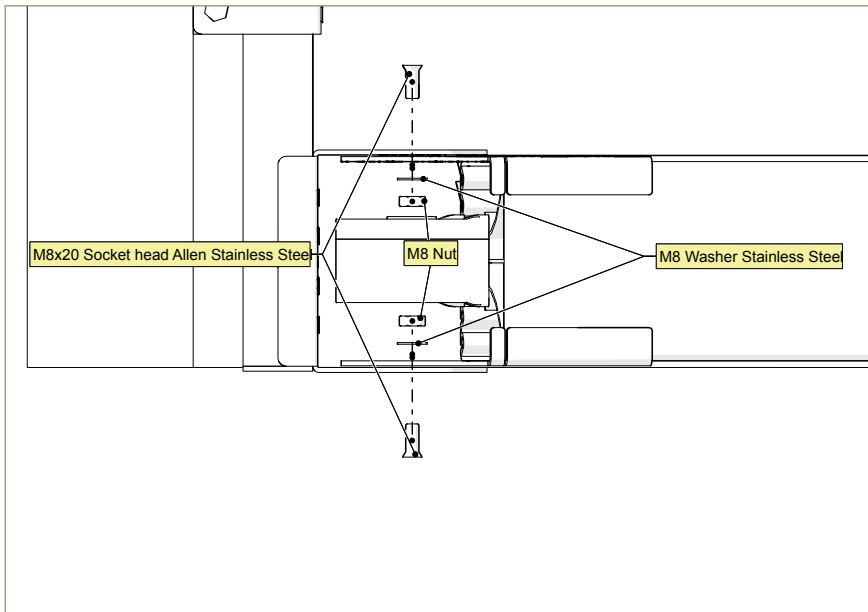

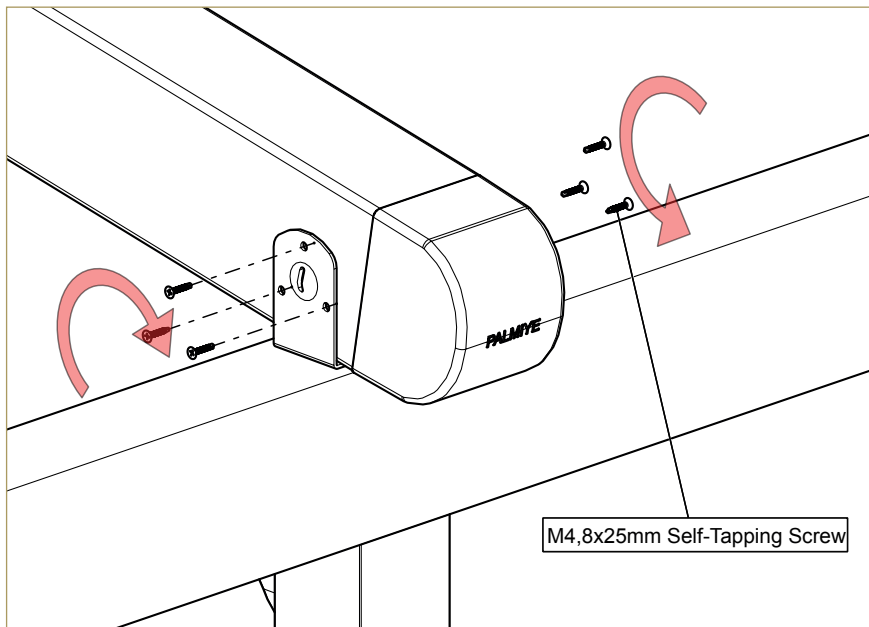

At first, just fasten one screw. The rest shall be fixed after cross check.

Lastly, put the rail caps.

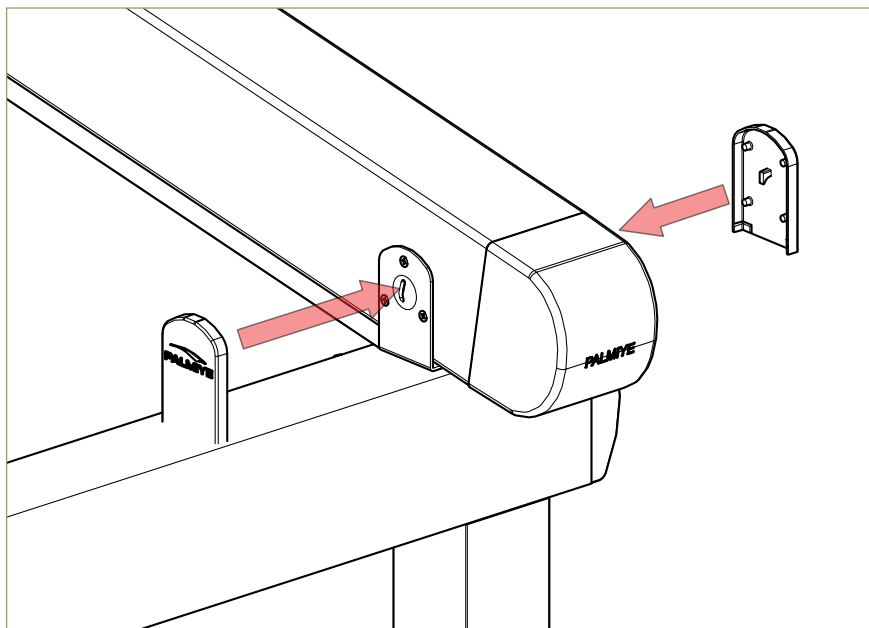



4.1.5. Cross Check and Level Control

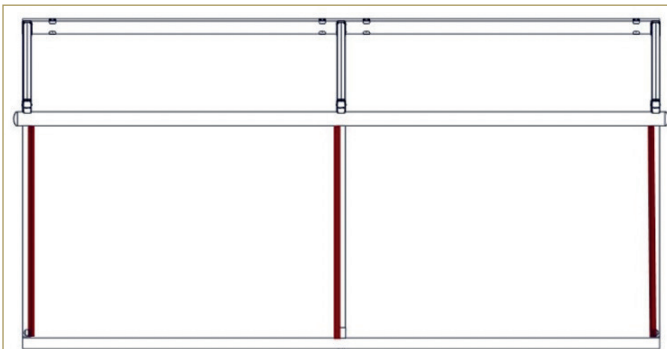
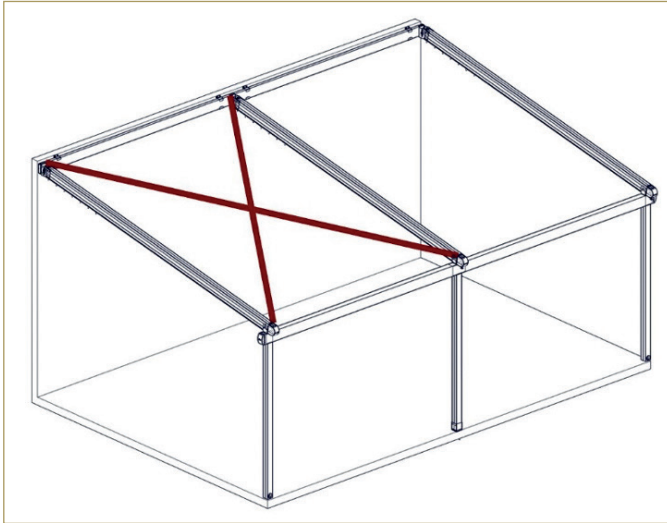
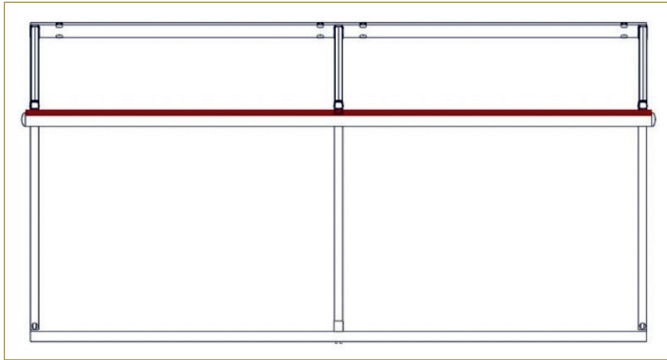



4.1.6. Pillar Fixing

Freestanding products have base plates on front pillar and on back pillar.

Unless otherwise stated, the flange directions shall be produced as shown in the diagram below. When you look at “plan view” base plates of all pillars stay inside of product border.

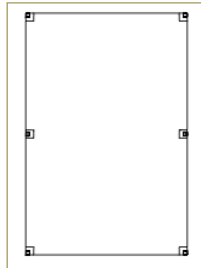

Freestanding products has base plate on pillars. The base plates are 200x200x10mm.

Front pillar – ground connection detail;

After the cross checks and level controls now, you can fix pillars to exact point. Make a hole with M16 drill bit (~20cm (8")) and clean to inside of the hole with exhauster from dust. Then apply a chemical anchor and place to the M12 Rod. Keep it and when the chemical anchor dry you can fix the nuts.

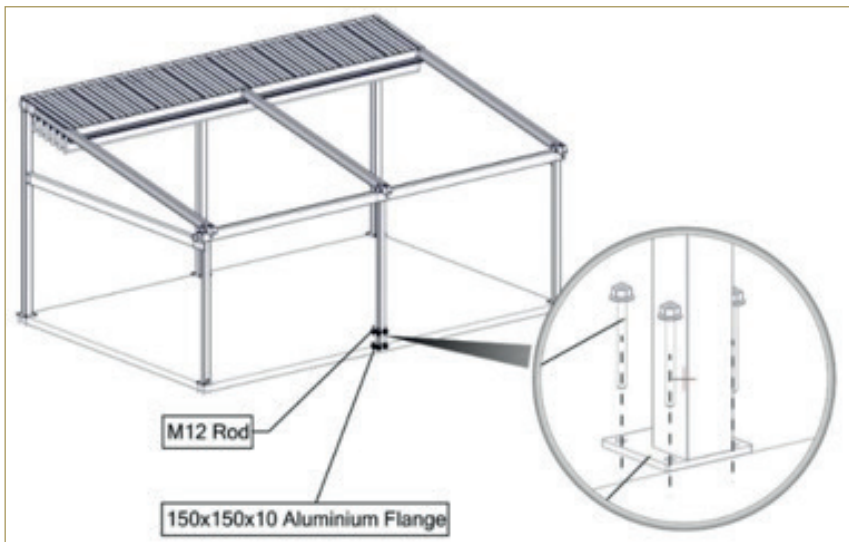

Back pillar – ground connection detail

After the cross checks and level controls now, you can fix pillars to exact point. Make a hole with M16 drill bit (~20cm (8")) and clean to inside of the hole with exhauster from dust. Then apply a chemical anchor and place to the M12 Rod. Keep it and when the chemical anchor dry you can fix the nuts.

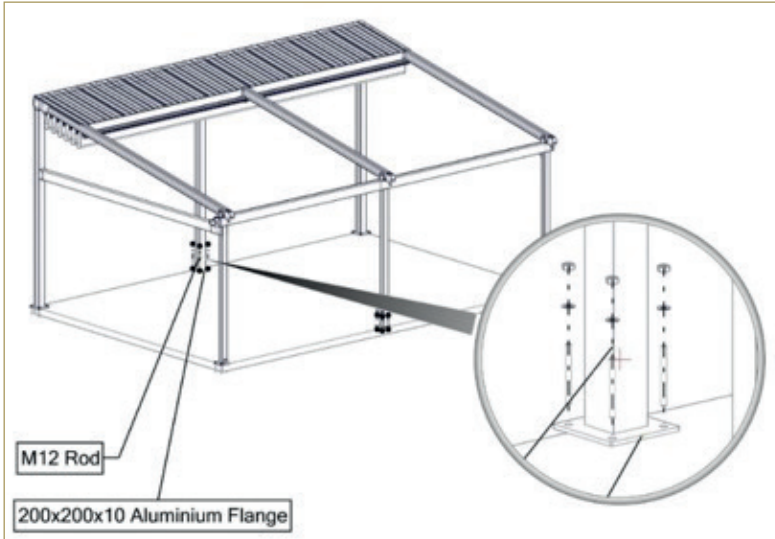

4.1.7. Gutter Fixing

Place the cap and fasten by screws.

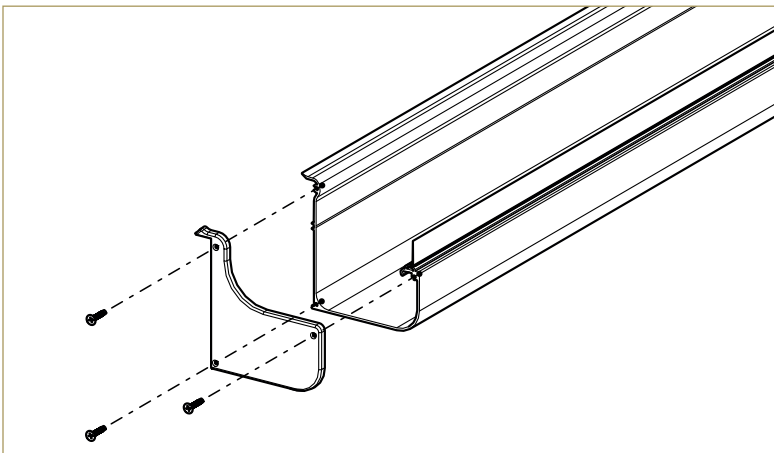

If there is water outlet on the corner pillar, make sure the gutter profile fits on the elbow properly.

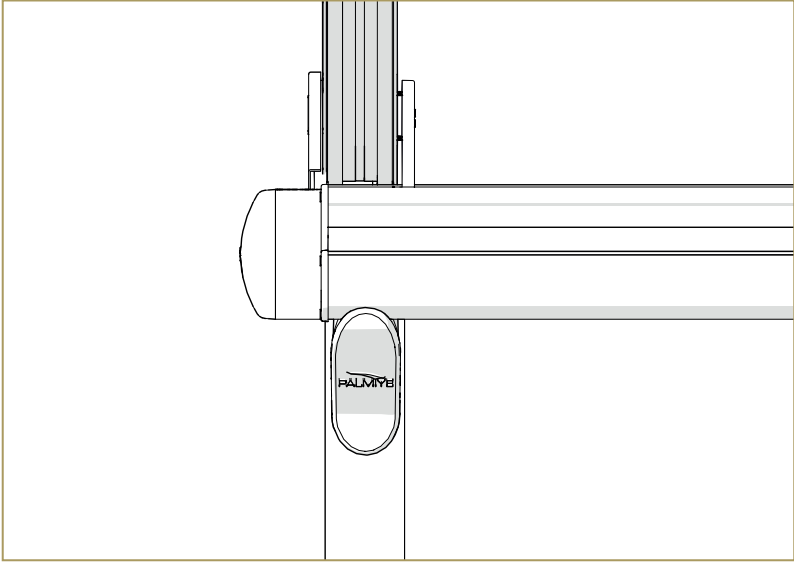

Place as temporary gutter profile to front beam in order to define the drainage hole and adjust according to the drainage elbow position and mark with pen on bottom of the gutter.

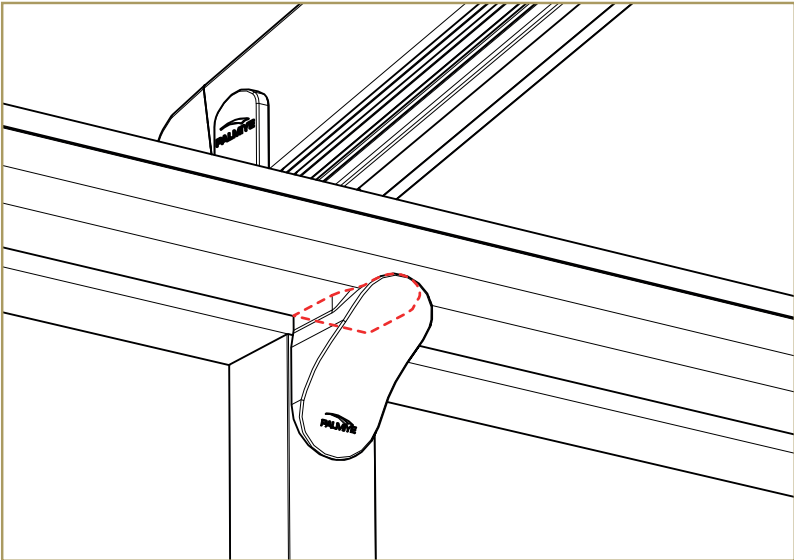

Using a punch, make a hole inside of the marked position for drainage. Create a drip edge with Palmiye's Gutter Hole Bending Apparatus (DMR.APR.P1066.ELGV).

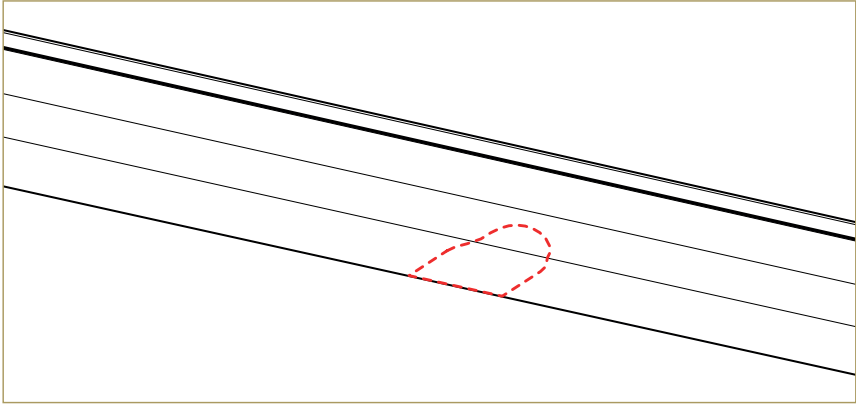

Apply the sealant behind the gutter profile before installing it.

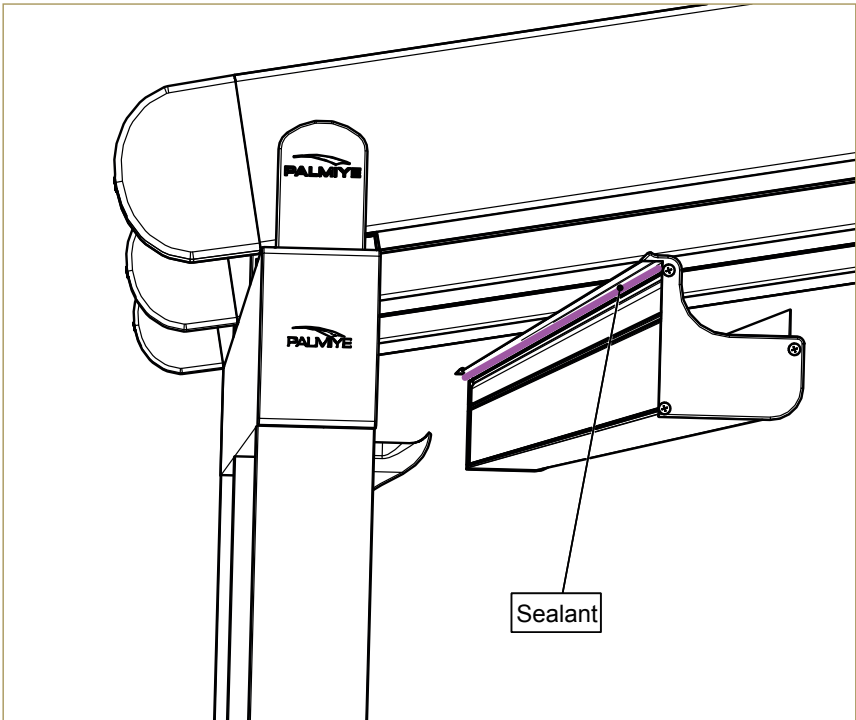

⚠ When the gutter profile is mounted, enough silicon should be apply to overflow.

Carry out to self-drilling screw related line on gutter.

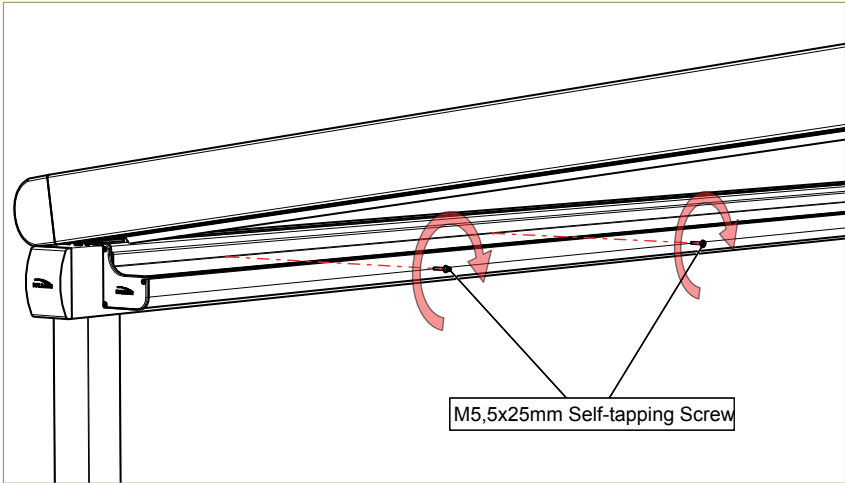

There are 6 types of gutter rubber size (Defined on your production document).

- SP130 = 30mm (1 3/16") only gutter gasket
- GS451 = 50mm (2") only gutter gasket
- 30 mm gutter gasket with 30 mm gutter gasket extension profile
- 30 mm gutter gasket with 50 mm gutter gasket extension profile
- 50 mm gutter gasket with 50 mm gutter gasket extension profile
- 50 mm gutter gasket with 30 mm gutter gasket extension profile

If you have two or more gutter profile you must use the gutter connector, place the connector to connection point.

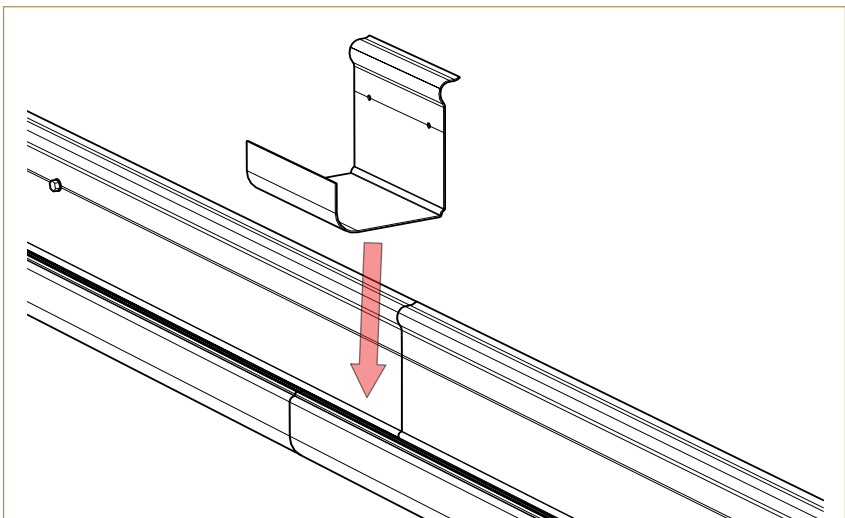

Fix gutter connector by M5,5x25mm self-drilling screw with washer.

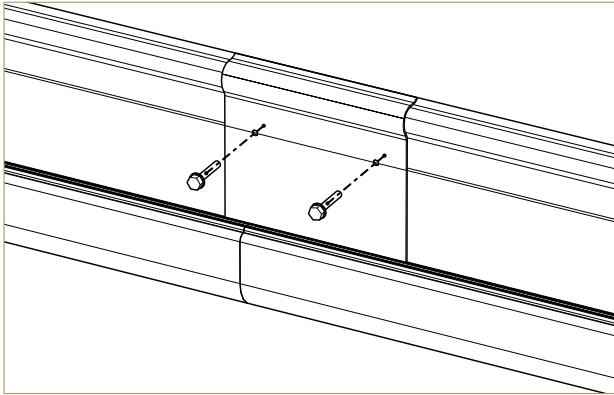

Apply a sealant around gutter connector.

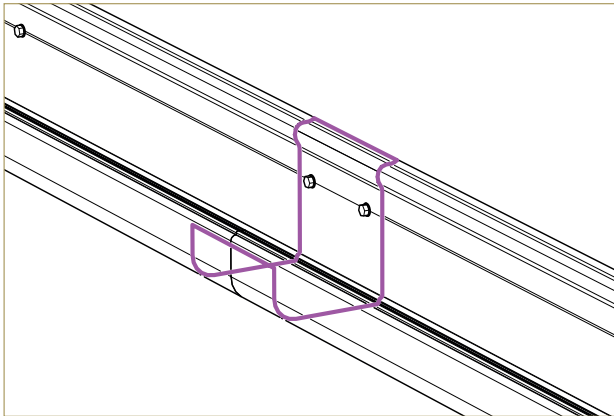

Place the gutter side cap to end of gutter.

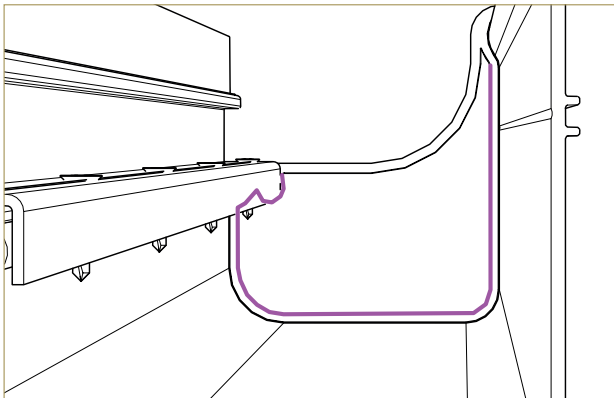

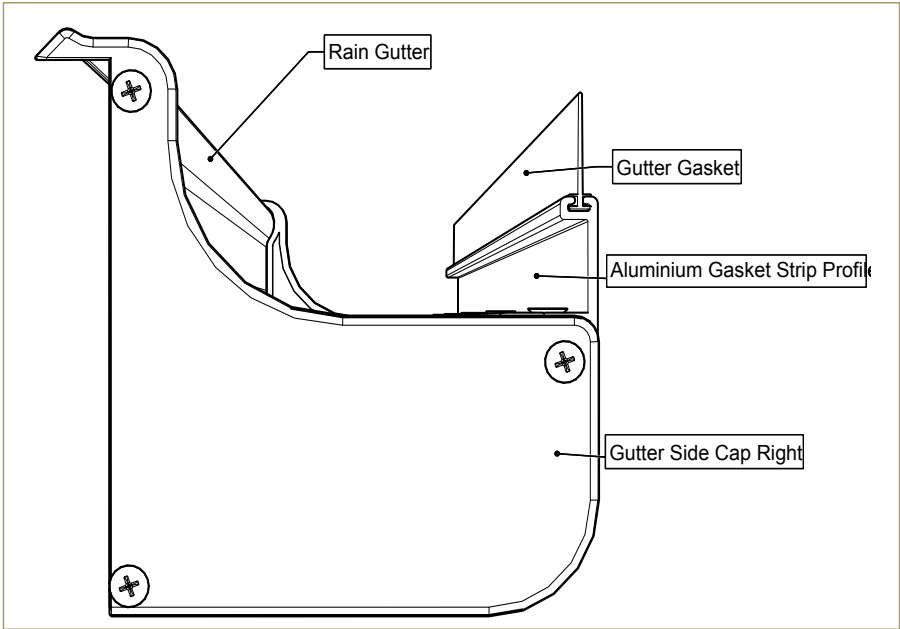

Applying type at below;

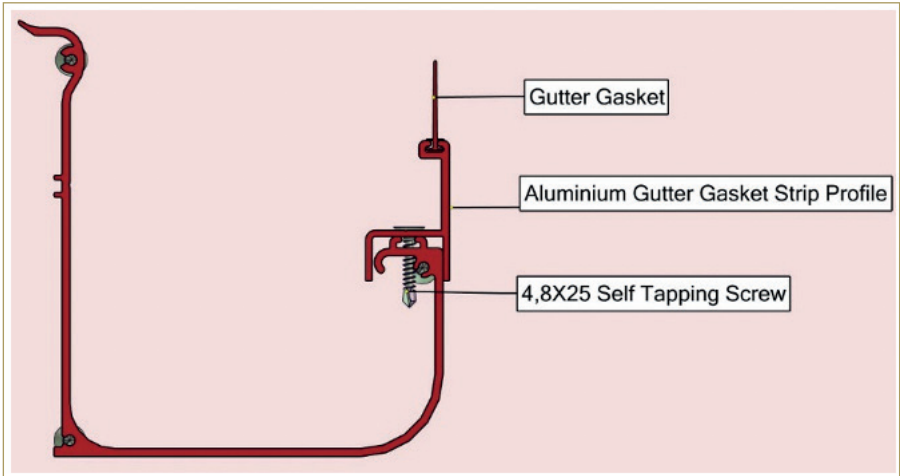

Place gasket to the gutter channel. Secondly, apply the adhesive glue as approximately 10cm (4") to gasket channel where is end of the gutter then the adhesive glue will dry. Pull back to gasket from other side. Thus, the gasket will be stretched. At this time apply the adhesive glue on the other side of the channel on the gutter. Finally, cut the gasket with knife.

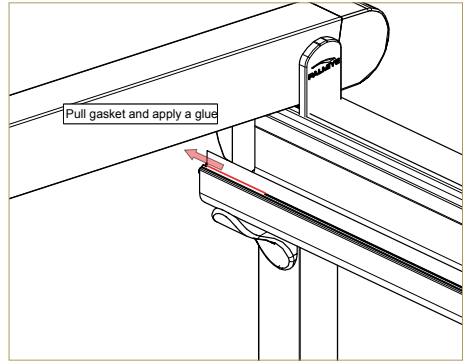
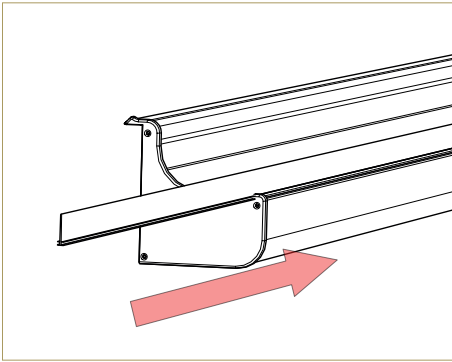

If a strainer is preferred, place the strainer on the water outlet in the gutter profile and apply silicone.

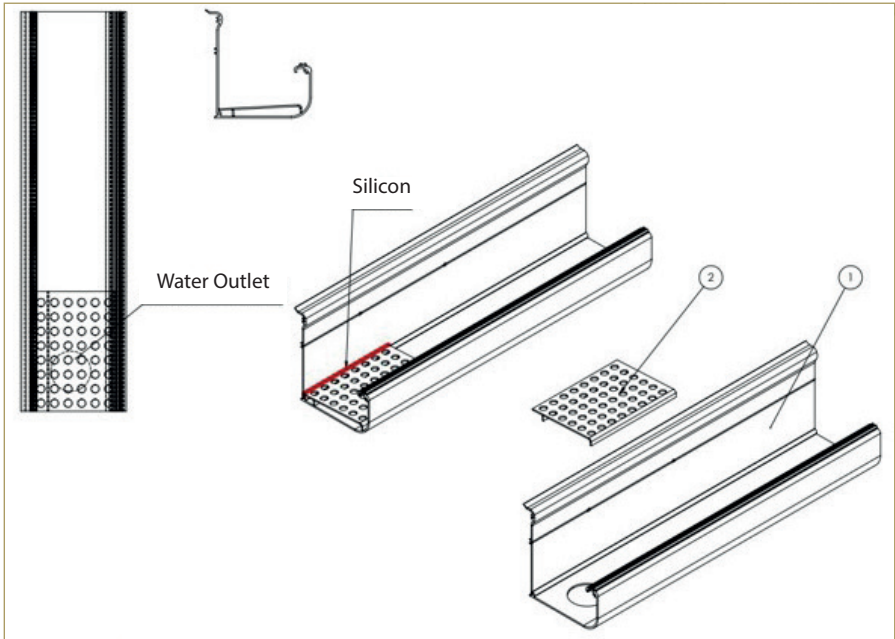

4.2. Motor Box Installation



4.2.1. Motor Box Fixing

Motor box should be centered in between two rails.

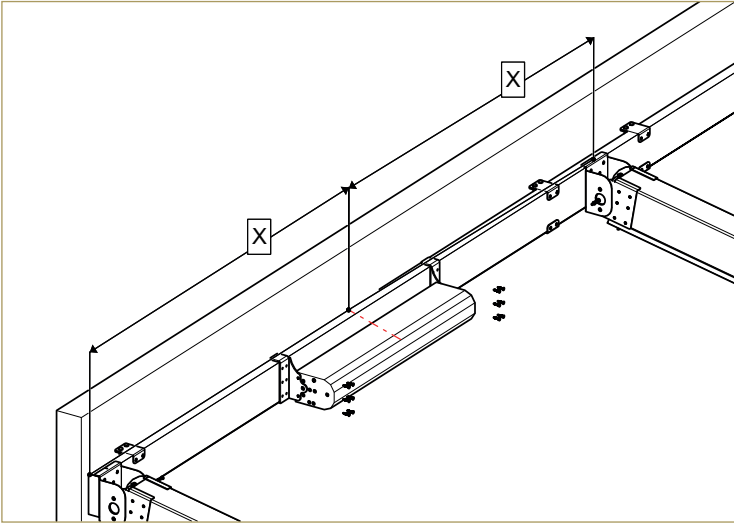

Motor box should be centered in between two rails.

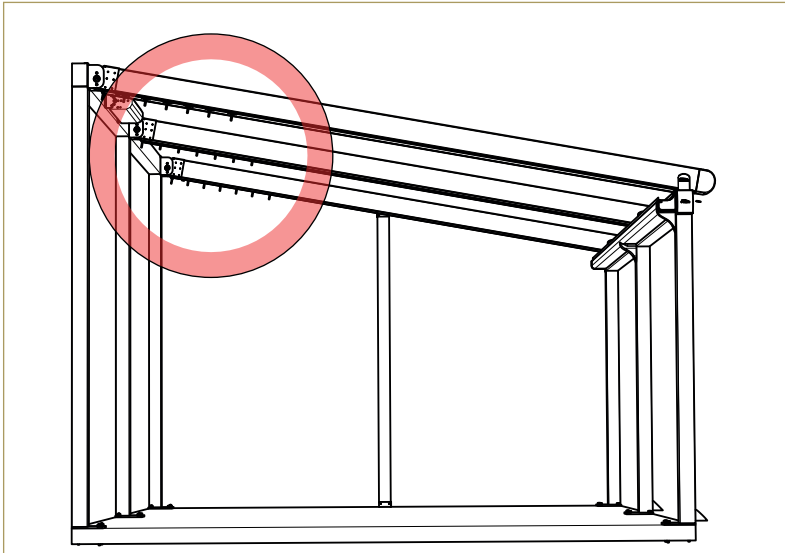

4.2.2. Motor Shaft Driver Installation

Place a Hexagonal shaft spindle to transmission tube. On edge sides 40cm (1' - 3 3/4") shaft spindle is used while on middle 70cm (2' - 4") shaft spindle is used.

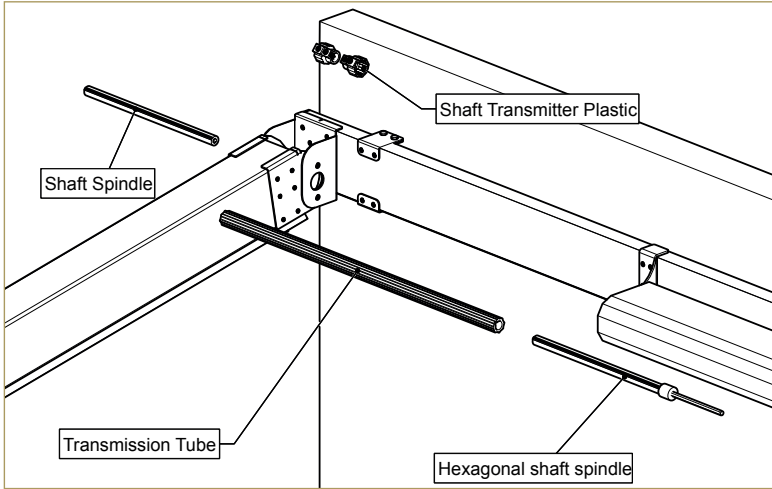

Place hexagonal shaft spindle and transmission tube to inside of the motor as you see in below figure.

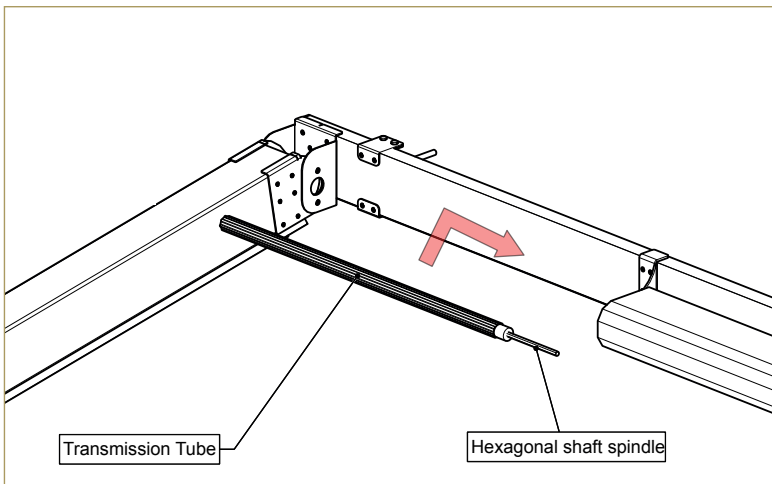

Insert a shaft transmitter plastic to transmission tube.

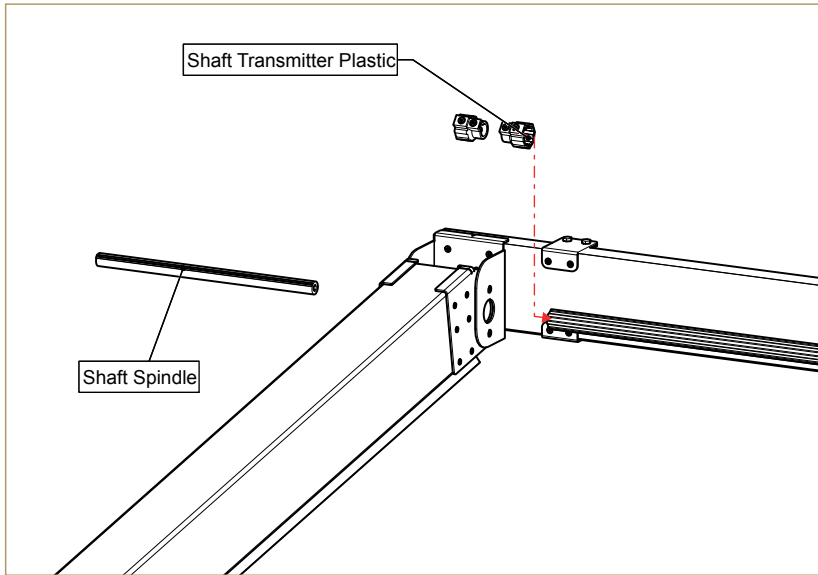

Place a shaft spindle and insert shaft transmitter plastic to there.

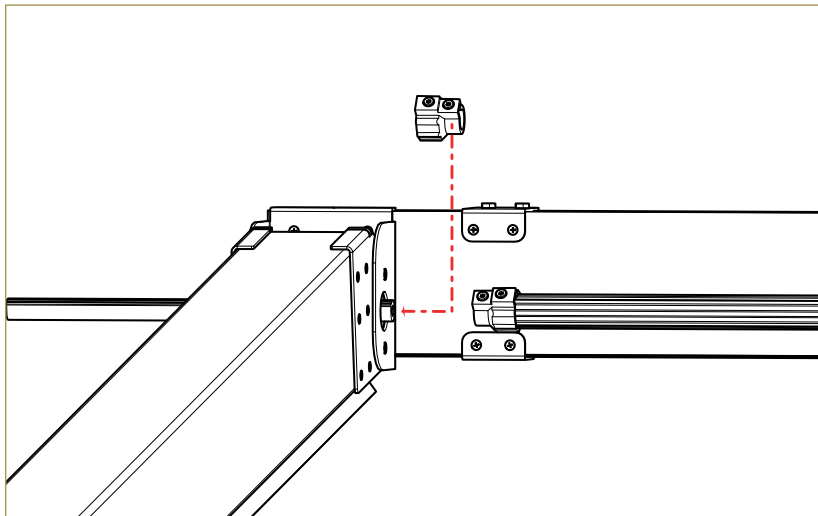

There must be at least 1cm (1/2") of gap between the rail bracket and the transmitter plastic.
Also, on edge side there are 2 shaft transmitter plastic.

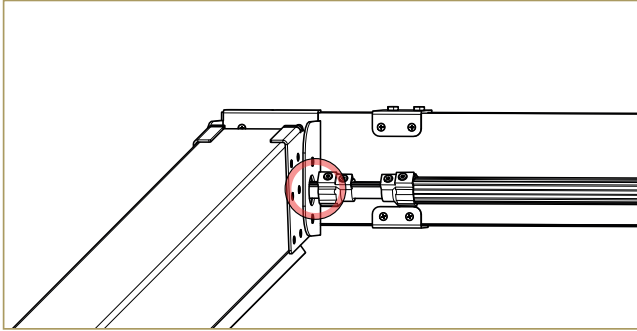

Fasten bolts on shaft transmitter plastic.

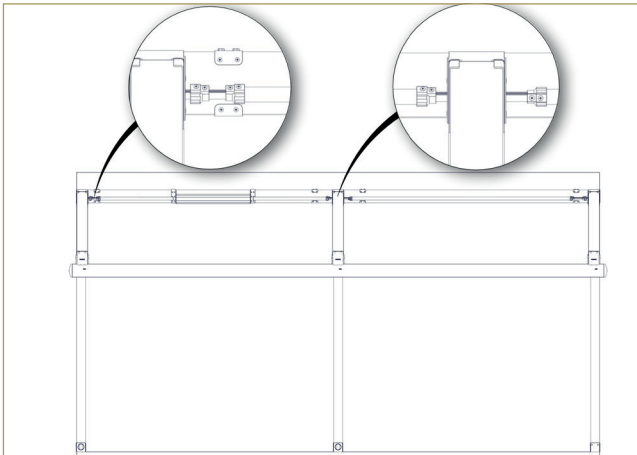

There is only 1 shaft transmitter plastic on each side on middle rail location.

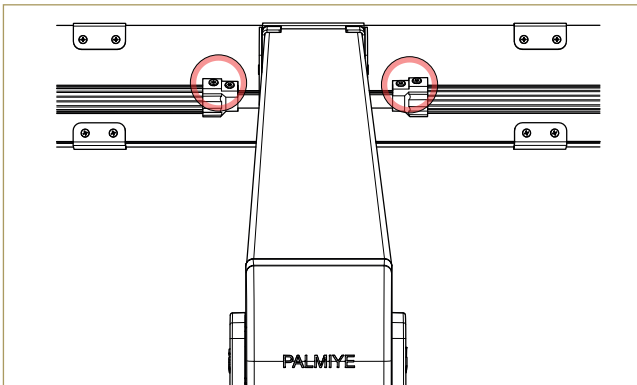



4.3. Fabric Installation

If the product width is bigger than 800cm (26' – 3"), the fabric support profile is not installed on the fabric in factory production. In this situation you must install the fabric support profiles to the fabric on site.

Double channeled fabric support profile's gasket goes to the end without any separation.

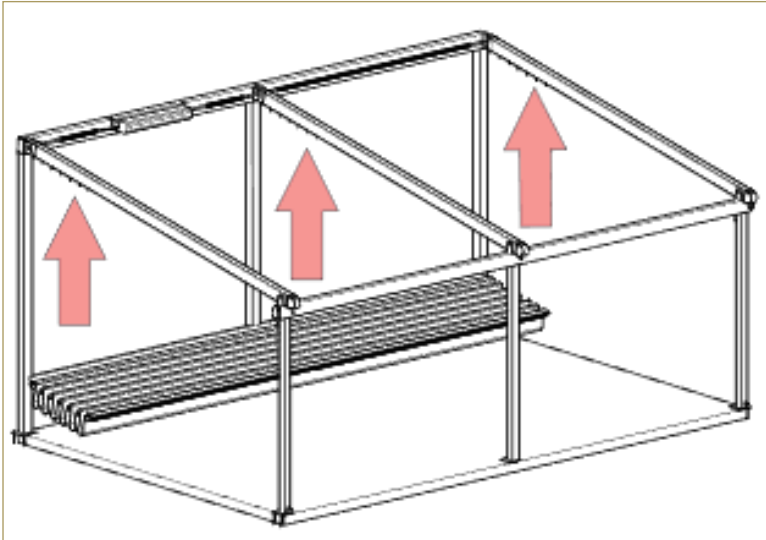

In this case, you must slide to middle plastics and middle fabric support profile from beginning to its location.

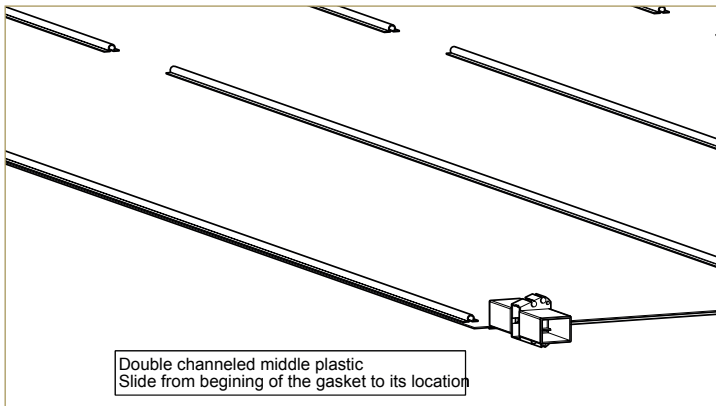

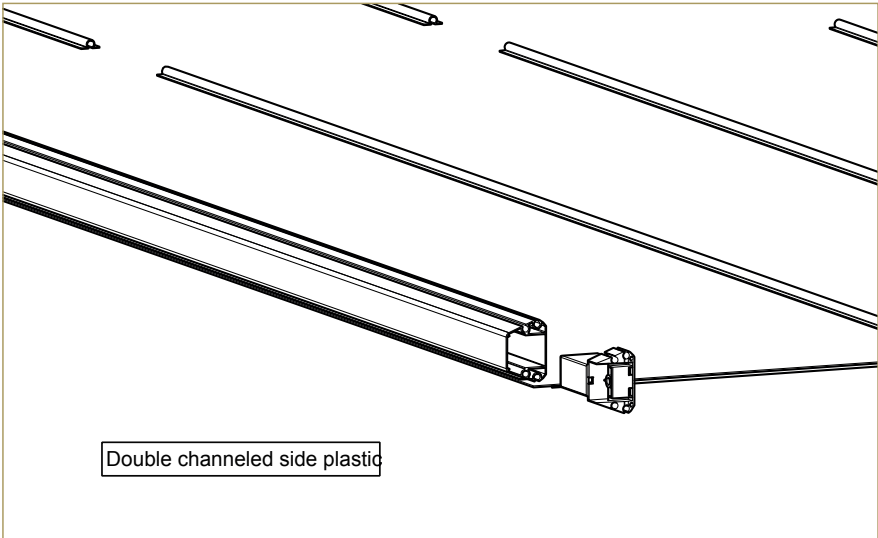
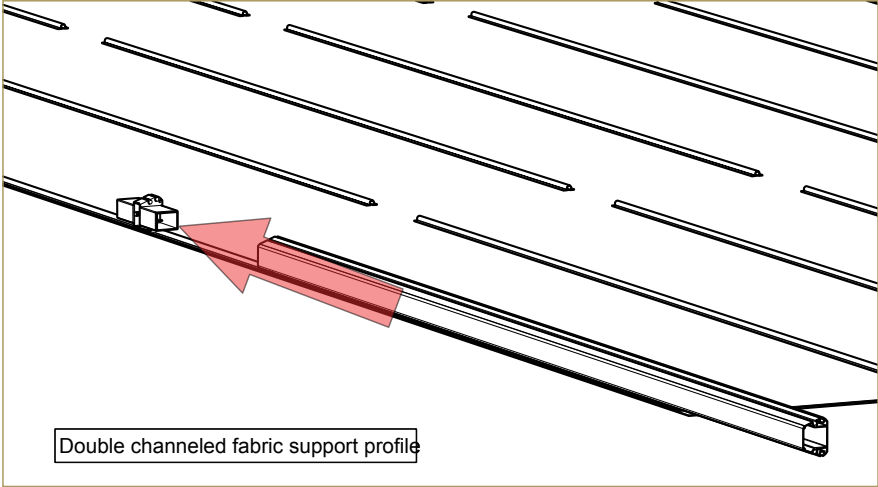

However, Single channeled fabric support profiles have designed a gap according to the rail position.

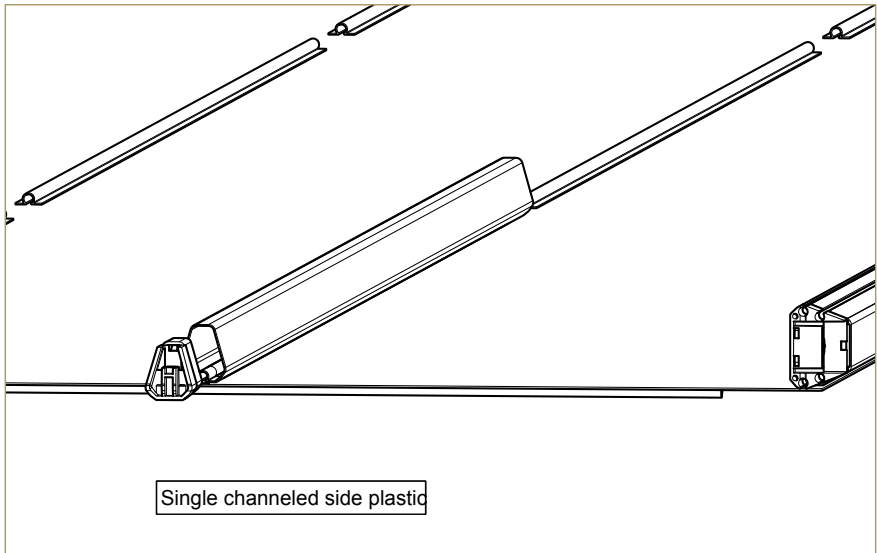
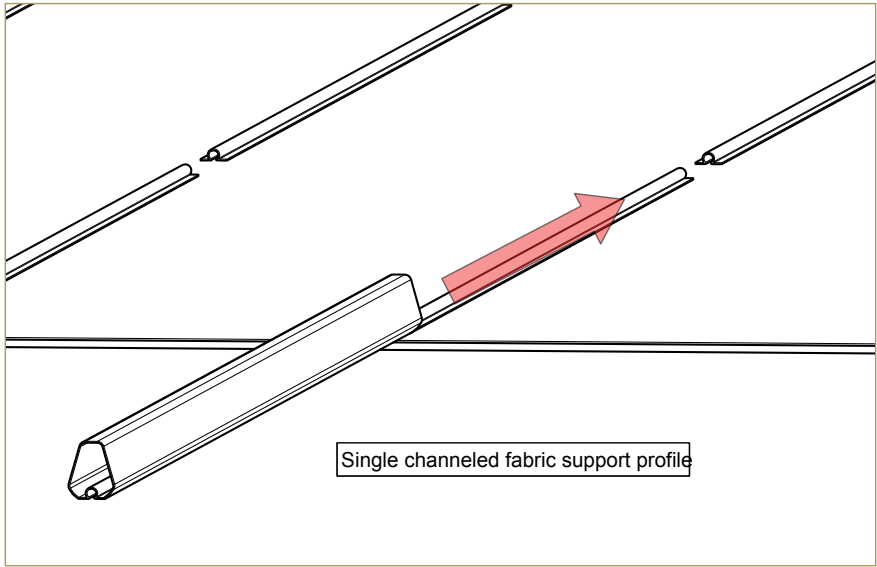

Note that if you have a lighting system, the fabric will be sent with wired harness. Therefore, profile with LED must be placed to related gasket which you can define with wire output at the side channel of fabric.

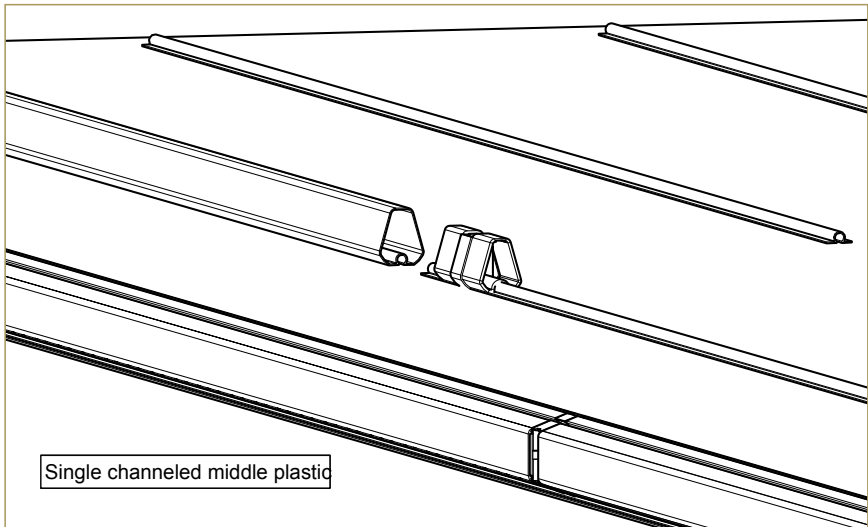

In order to cabling, exiting hole can be used in the side plastic.

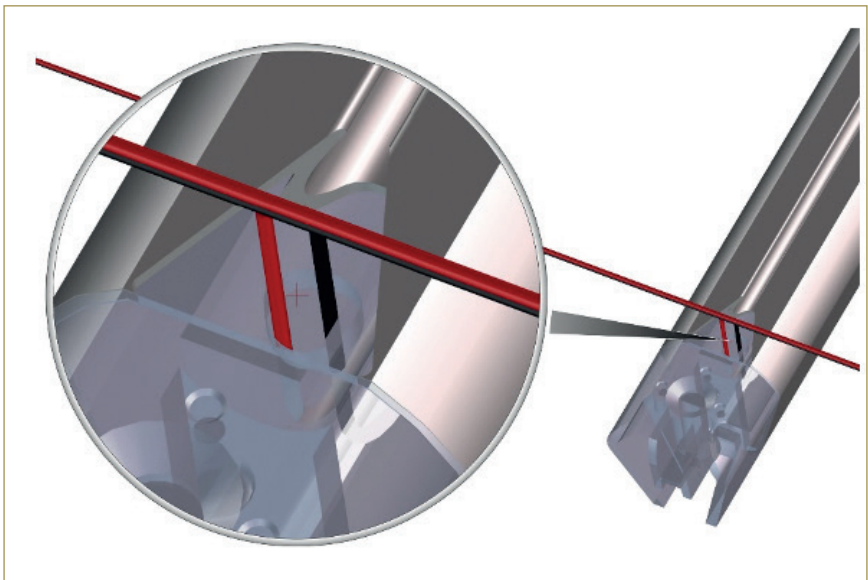

Part Code: DMR.APR.G1106.YMMX

First you need to fix one side of fabric support profile.

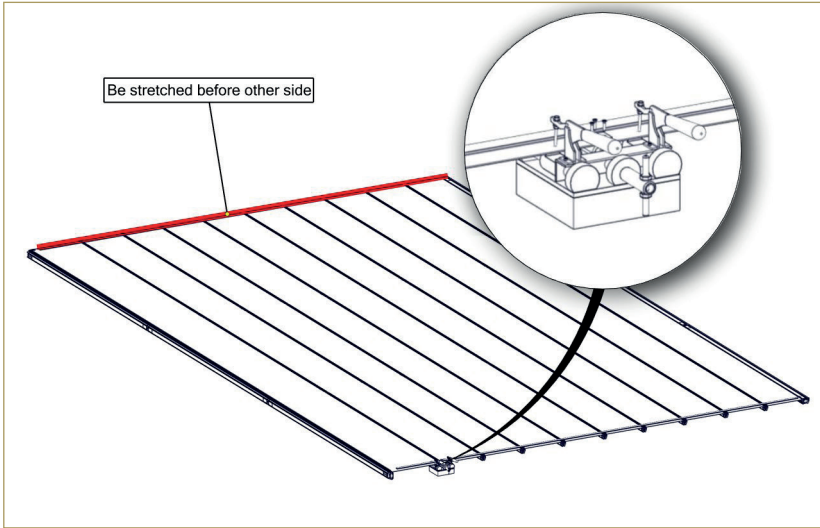

The fabric should be stretch properly. In order to this, PALMIYE designed a special tool called Fabric Stretching Equipment . When fabric is pulled to the end of the fabric support profile it means fabric has stretched.

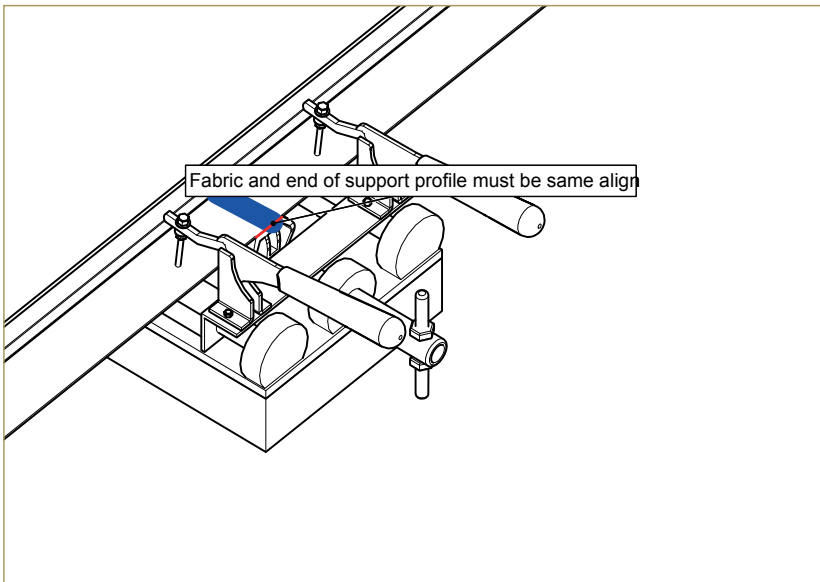

After stretching you need to fix it.

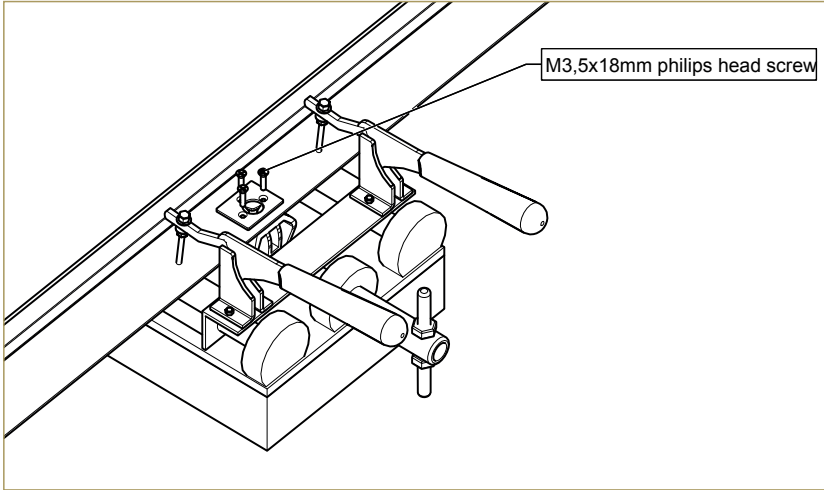

In order to install to the retractable pergola carriers there must be a hole. You should make a hole carefully by Palmiye special fabric hole cutter.

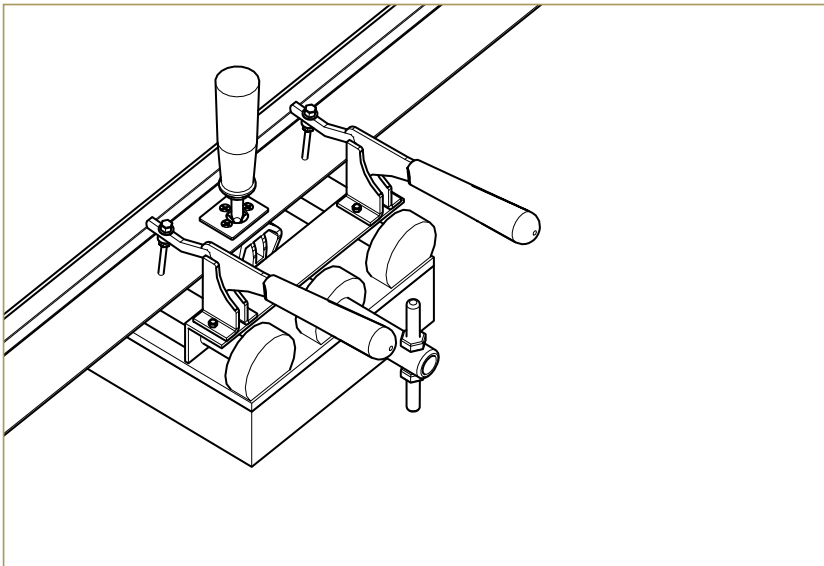

Part Code: HRD.TKM.G1039.BRUT



When you stretched to whole fabric support profile the fabric will be ready to integrate to retractable pergola.



In this operation you should use to lift or our special fabric elevator. Thus, you are able to lift up without any damage to the fabric.

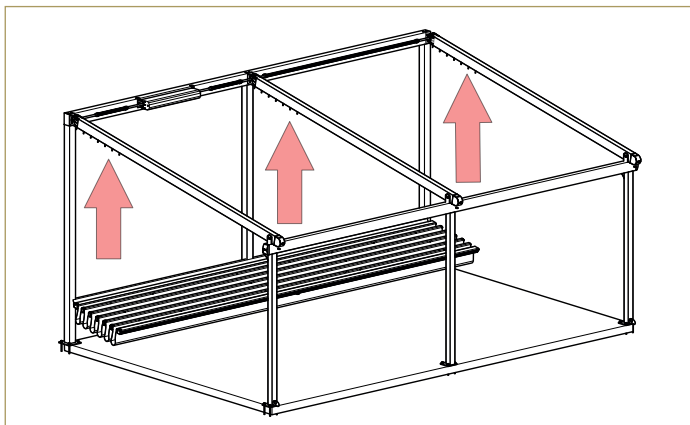

Fabric support profile connection points needs to be lifted aligned and at same time.

While installing a fabric, you must fasten to nut simultaneously with same align fabric support profile side plastic.

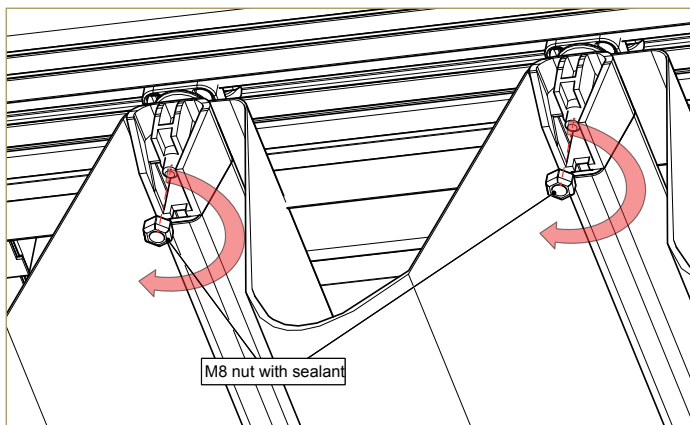

Part Code: DMR.APR.G1107.YMMX



If you have a decorative fabric, you must follow the same operations. In addition, you should slide the deco fabric then fasten from one side then stretch other side.

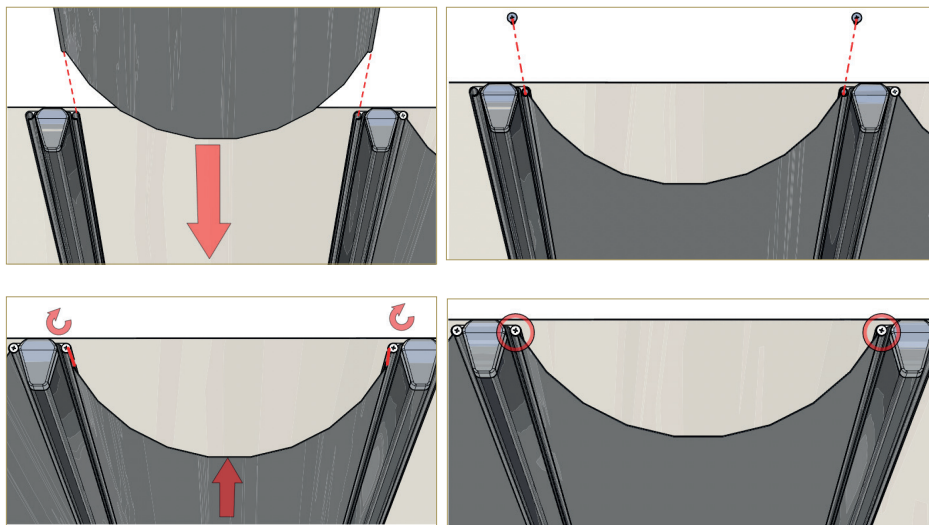

At the end the valance fabric shall be installed to the back-fabric support profile. Firstly, there must be fix valance strip profile to bottom of the back beam.

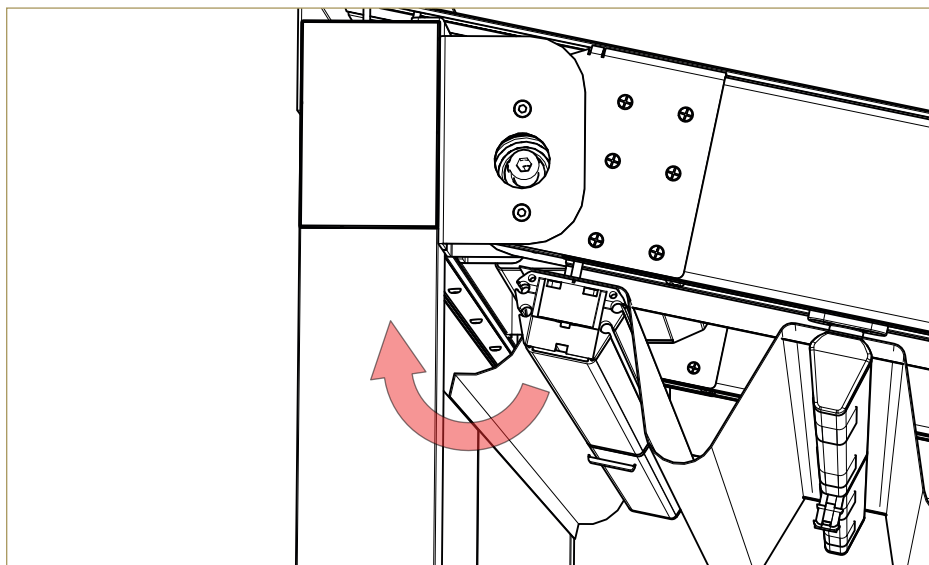

Now, you can use Velcro on the valance profile and valance fabric, you can stick fabric using Velcro.

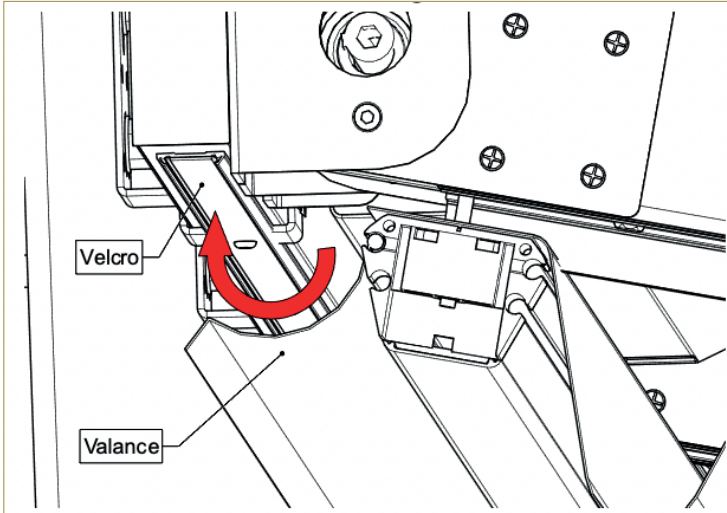

4.4. Cross Beam Installation

In order to fix the cross beam, you should define an exact U Bracket position. It means, firstly you have to check fabric cover sheet length, after that you can place to U bracket according to that dimension.

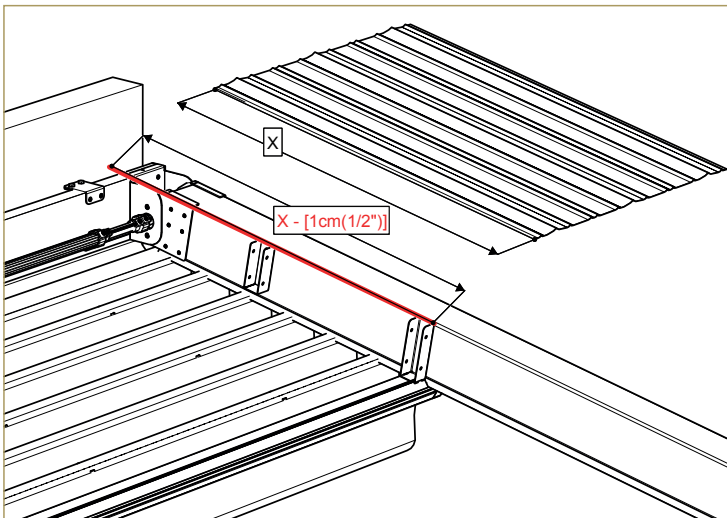

The fabric cover sheet must be extended from the cross beam at least 1 cm (1/2").

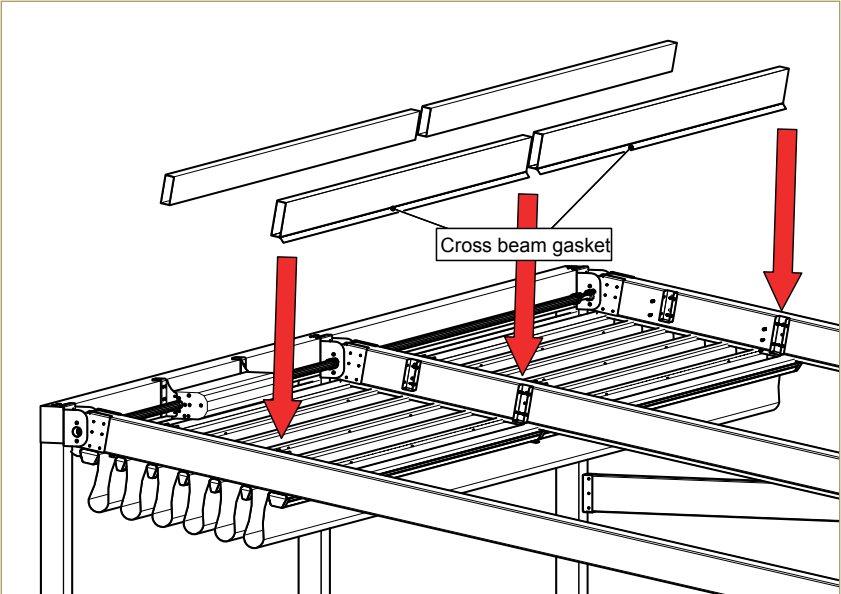
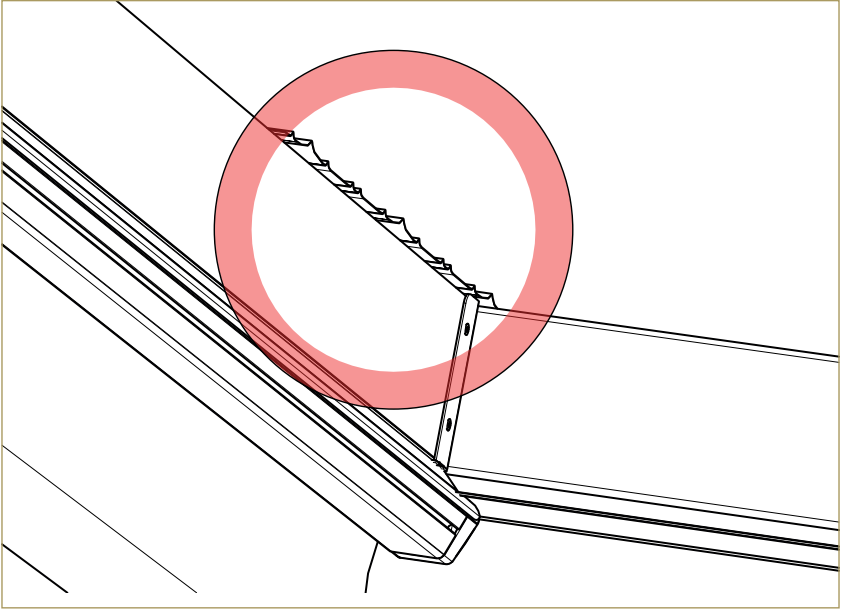

There are 2 different cross beam which is 40x120mm it's located on back and frontier is 42x150mm with gasket. The gasket ensures that air does not leak.

4.4.1. Control Box Installation

Synchronized motor control box and / or lighting control box can fix to the cross beams.



In this case, the control box shouldn't touch the fabric cover sheet on top.

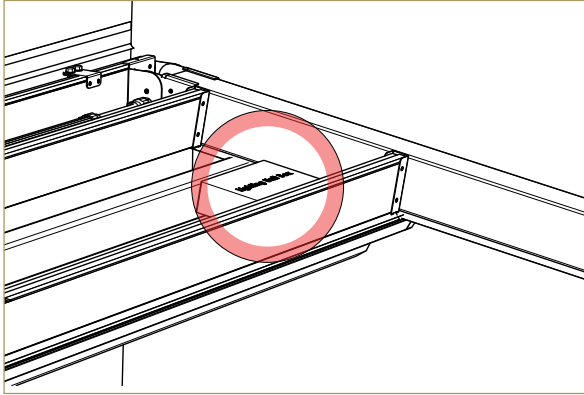

4.4.2. Exact Covering

If there is a gap between front fabric profile and gutter.

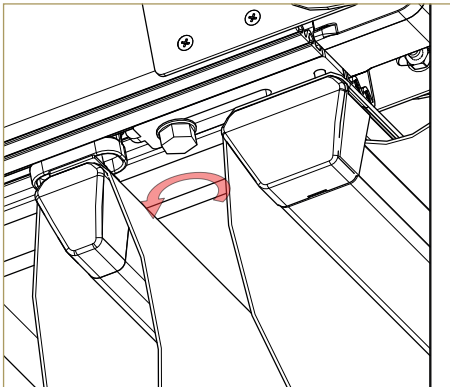
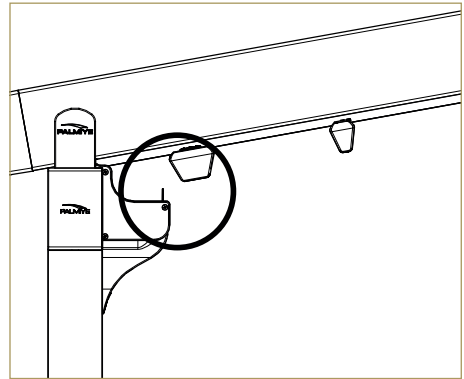

You can make the needed adjustment from fixed corner adjust from fixed carrier (located on back of the rail) needed adjustment. First, loose the nut on fixed carrier.

Secondly, adjust proper position and tighten the nut. And place the back-fabric support profile.

 All fixed carriers should move at equal distance from the end of rail profile.

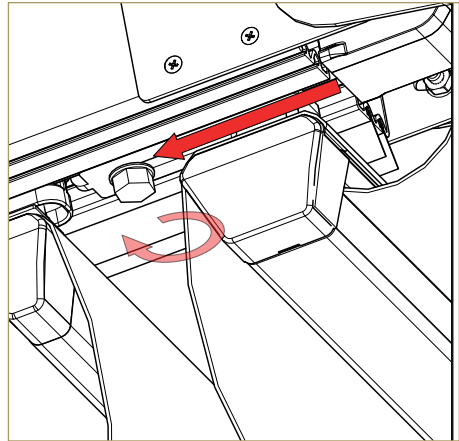

4.5. Module Connection

If there are two products where is located side by side, you must apply a sealant.

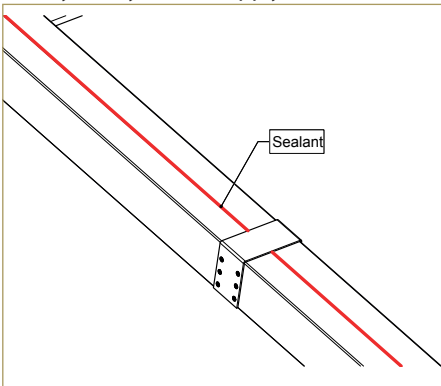

Place T profile.

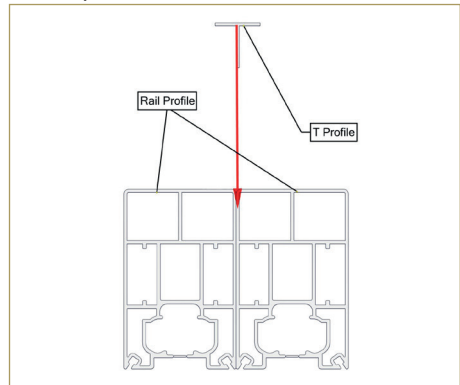

Then place a module connector.

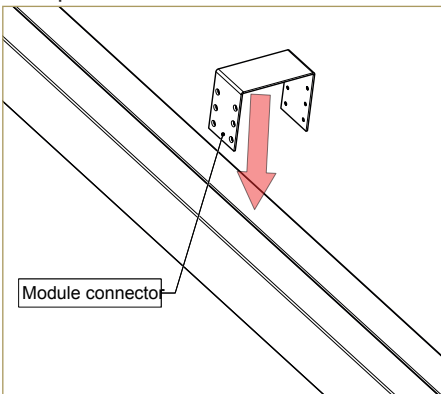

Finally, fasten screws.

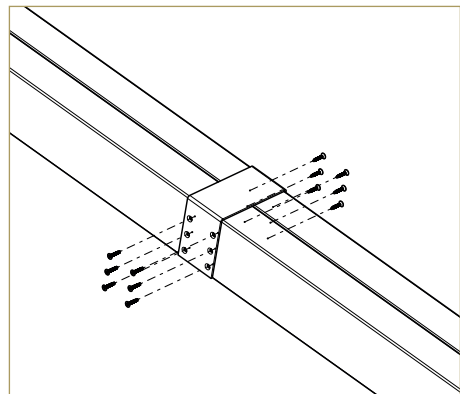

4.6. Fabric Cover Sheet Installation



4.6.1. Side Covering

Before fabric cover sheet fixing, you can place the side cover profile;

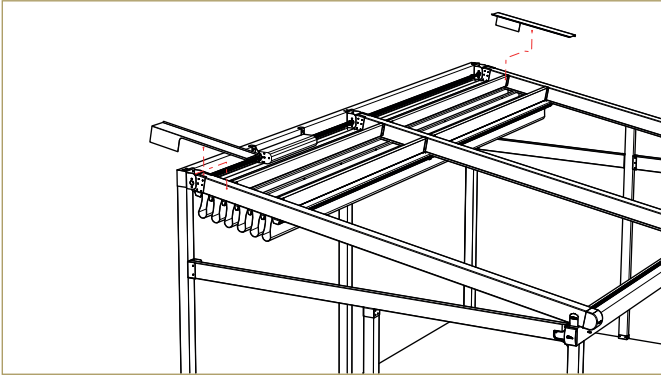

4.6.2. Fabric Cover Sheet

Place the fabric cover sheets.

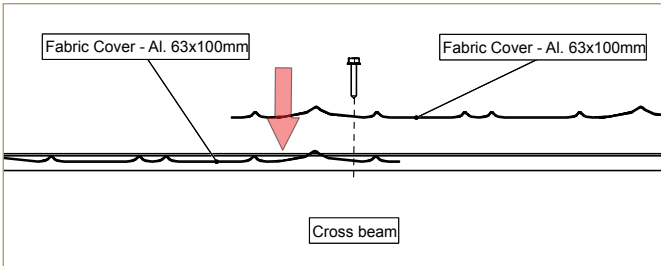

At the end fix by M5,5x25mm self-tapping screw.

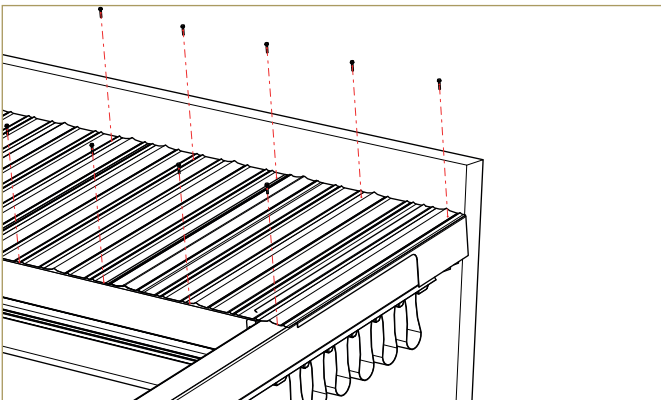



4.6.3. Back Finish

100x100mm angle is used for back finish.

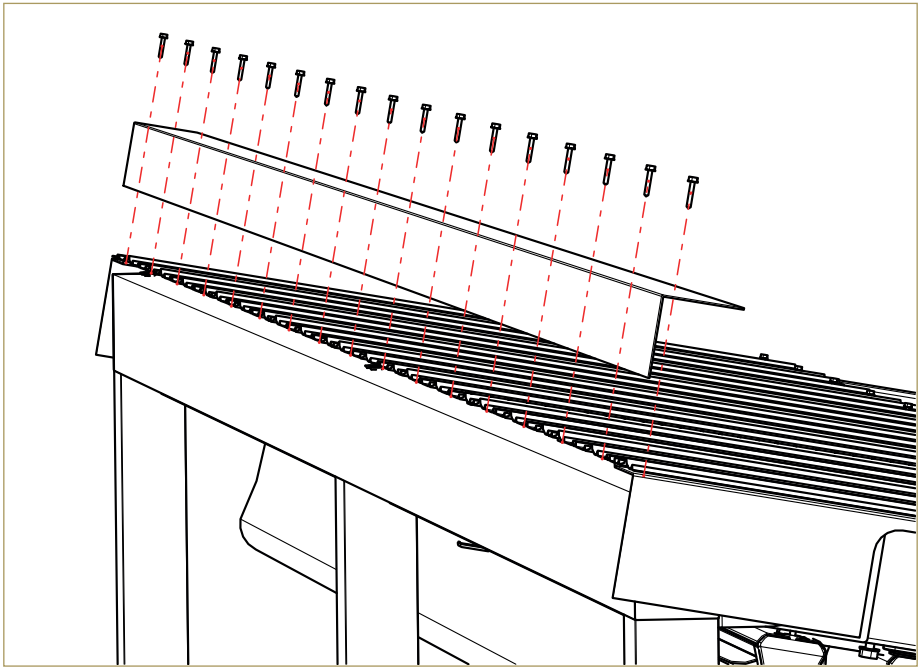

4.7. Side Beam

80x130mm Aluminium

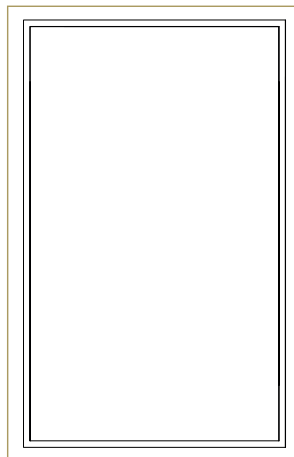



4.7.1. Fixing L Bracket to Front Beam

L Bracket must be fix 6mm (2 1/2") outside of the corner pillar alignment.

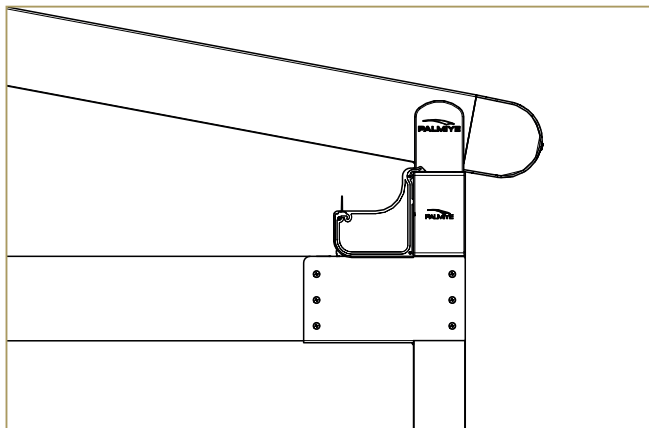
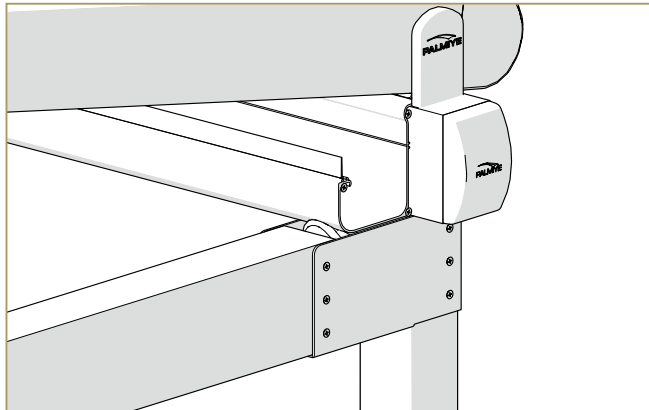
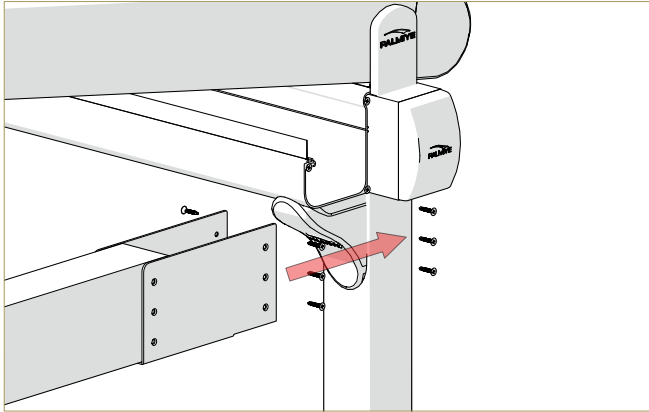

4.7.2. Fixing U Bracket to Wall/Side Beam Back Pillar

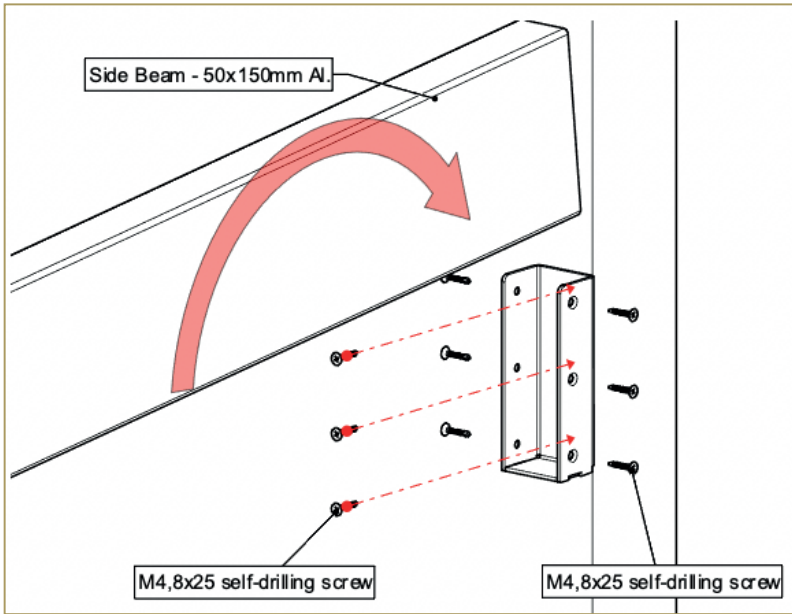

If there is a triangle glass product, a sealant must be applied on top of the side beam profile.

Place side beam to U bracket on back and align with L bracket on front then fasten screws.

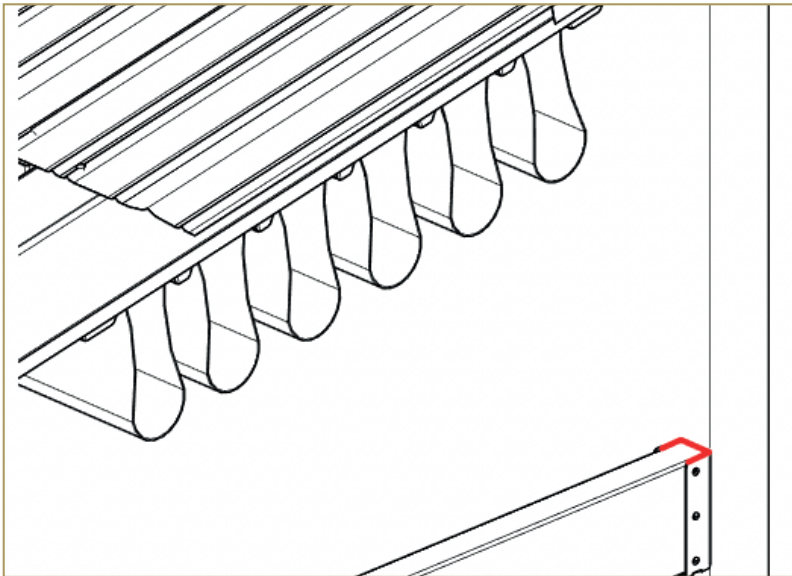



4.7.3. Side Beam Pillar

4.7.4. Until to Side Beam

For 80x130mm side beam; 80x80mm side beam pillar is used.

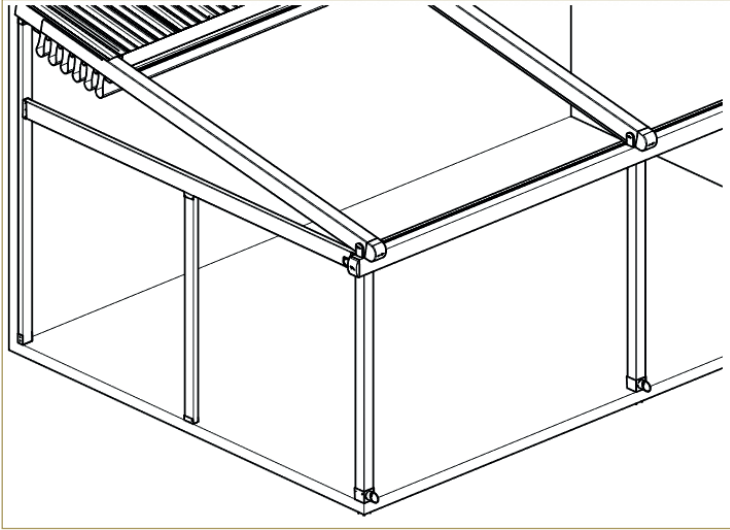

Define the side beam pillar top U bracket and fasten screws to side beam as you see at below.

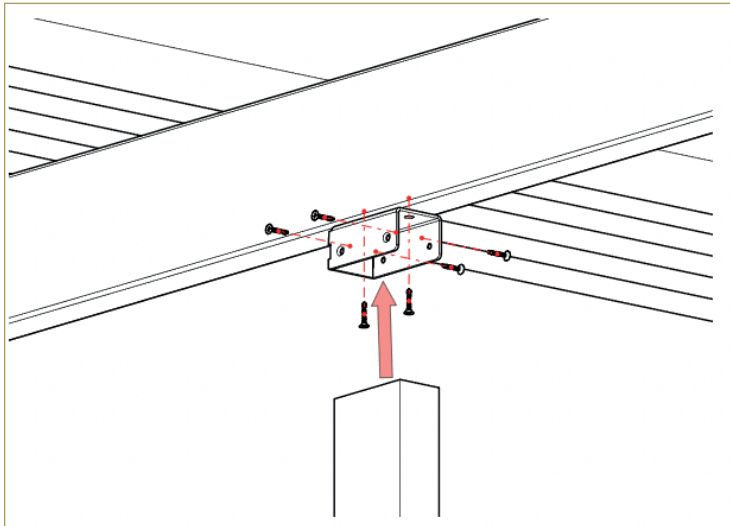

5. PROGRAMMING / RESETTING OF MOTOR AND LIGHTS

5.1. Attention

The installation and initial setup procedures are the responsibility of a specialized technician. When retractable pergola system is mounted, check the connection of drive system which is control box for double motor systems or connected to the single motor as directly.

- All wiring must conform to NEC (National Electrical Code) and local codes.

Power input:

- For the double motor systems: The power has to connect to the Control Unit box.
- For single motor systems: the power has to connect to the single motors.
- For lighting system: The power has to connect to the Lighting Control Unit box.
- PALMIYE Reserves the right to void the motor warranty if wiring recommendations are not followed.
- The Motor Control Unit Boxes works with 230VAC / 50~60Hz
- Lighting Control Unit Boxes works with 120-230VAC / 50~60Hz
- Single motor works 120VAC / 60Hz or 230VAC / 50Hz.
- If the installation is made up of several RTS system, only one RTS system must be powered during programming. All other RTS systems must be disconnected. This will avoid interferences during the initial programming of each motor.
- Use only SOMFY RTS radio controls. The receiver (433,42 MHz) must be programmed with transmitters.

5.2. Remote Control Button Configurations

Silver Compact Freestanding is integrated with linear tube motor with radio control for opening, closing or stopping the fabric support profiles use the respective buttons (see figure). There are 4 different remote-control models.

Pure, Patio, Lounge, Modulis;

- Situo 1 RTS (has only one channel. It means it can control 1 RTS motor).
- Situo 5 RTS (has 5 channels. It means it can control 5 different RTS motor).
- Telis 16 (has 16 channels. It means it can control 16 different RTS motor).

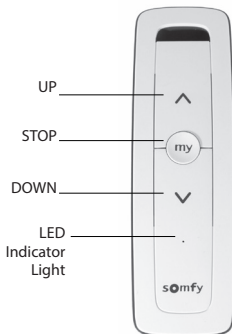

Single Channel Version

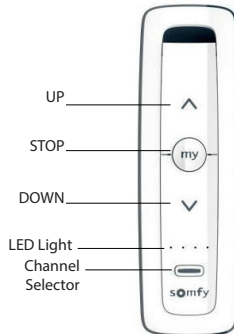

Five Channel Version

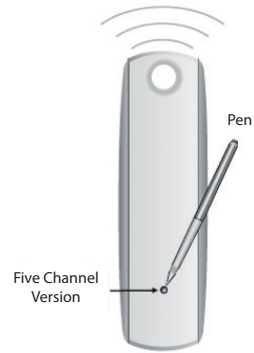

Back

5.3. Remote Types



Situo 1 RTS

Situo 5 RTS

TELIS 16

Channels	1	5	16
Battery Type	2430 Lithium		LR03AAA
Battery Voltage	3V		1,5 V
Thickness	22		18
Width	49		47
Height	145		151
Colour	Silver		Silver & Pure
Compatibility	Compatible with a range of Somfy RTS enabled products		
Radio Frequency	For indoor use		
Radio Range	433,42 MHz		
Protection Index	200m in open field or 20m through 2 reinforced concrete walls		
Working temperature	IP30		
Information	0C to + 60C		
Installation	Wall brackets supplied		

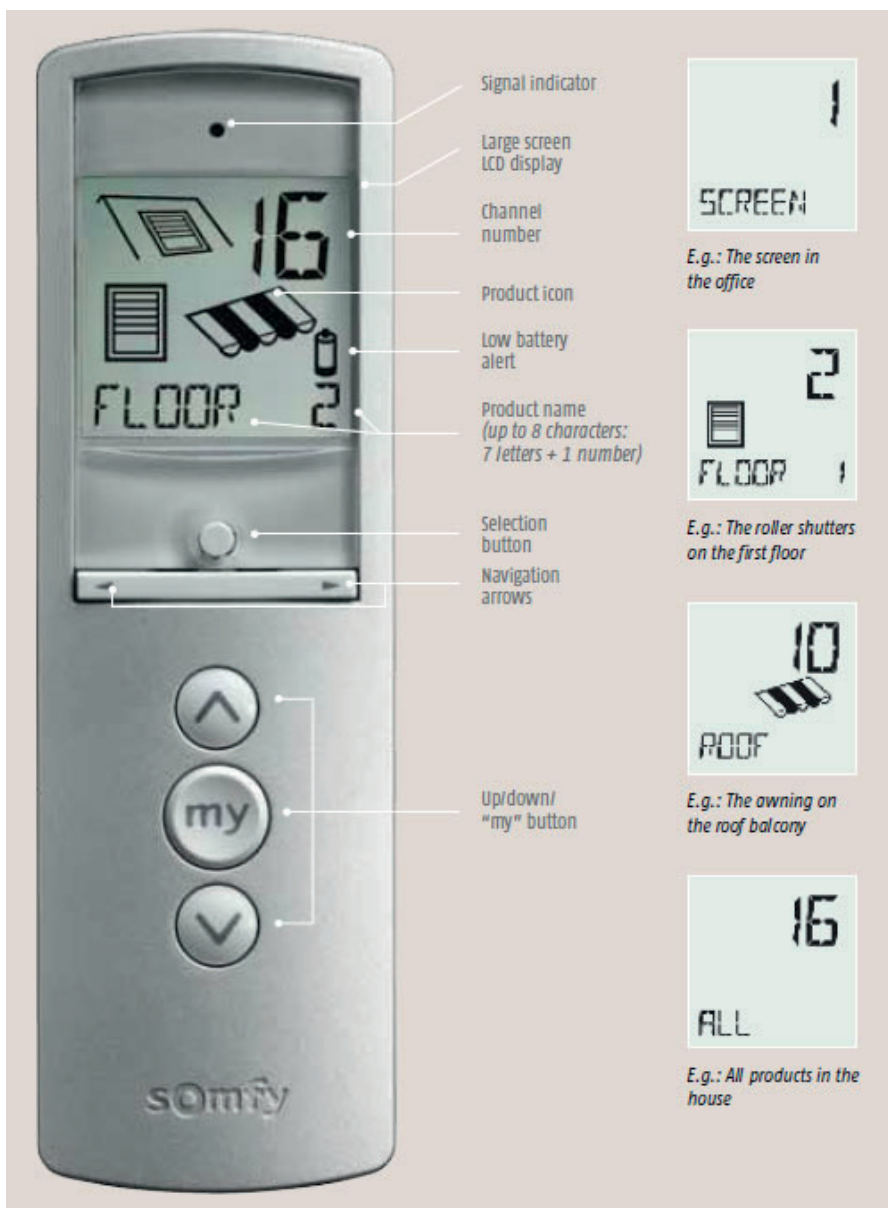

Signal indicator

Large screen LCD display

Channel number

Product icon

Low battery alert

Product name
(up to 8 characters:
7 letters + 1 number)

Selection button

Navigation arrows

Up/down/
"my" button



E.g.: The screen in the office



E.g.: The roller shutters on the first floor



E.g.: The awning on the roof balcony



E.g.: All products in the house

5.4. Replacing The Battery



Using a small screwdriver loosen the screws on the reverse side of the remote control and remove the back cover.

Replace the battery with one 2430 Lithium 3V Battery.

5.5. Programming

5.5.1. Single Motor (OREA RTS) for 230VAC / 50Hz

Step 1: There isn't any control unit box at single motor products. Therefore, you are able to connect directly to electric power unit (230VAC / 50Hz). Notice the motor will not respond to any transmitter until a transmitter is assigned to communicate with the motor's receiver.

Step 2: Please select desired channel then to assign the transmitter to communicate with the motor's receiver, push the "UP" and "DOWN" buttons on the transmitter SIMULTANEOUSLY, motor will jog. The OREA RTS motor records the address of this transmitter, and only this activated transmitter can be recorded into the memory of the OREA RTS motor.

Step 3: Check direction of operation. The "UP" button must correspond to FRONT on the end-product. In the case of a pergola, it will stretch the ceiling cover of the pergola. If the direction is wrong, change the direction by pressing "MY" button until the motor jogs (3 seconds).

Step 4: Stop the motor at the desired BACK limit. Align the double channel fabric support profile to the cross beam.

Step 5: To set the BACK limit, press the "MY" and "UP" buttons SIMULTANEOUSLY for more than 2 seconds. Release the buttons once the product begins to move towards front of the Pergola.

Step 6: Press "MY" button and the motor will stop.

Step 7: Press “MY” button CONSTANTLY until motor jogs to confirm the settings (5 seconds).

Step 8: Finally, press the “PROGRAMING BUTTON” on the back of the transmitter until the motor jogs (to leave the installation mode).

*Front limit doesn't need to be set for Single Motor (OREA RTS) product as the motor will stop automatically when fabric is stretch.

5.5.2. Single Motor (ALTUS 50 RTS) for 120VAC / 60Hz

Step 1: There isn't any control unit box at single motor products. Therefore, you are able to connect directly to electric power unit (120VAC / 60Hz). Notice the motor will not respond to any transmitter until a transmitter is assigned to communicate with the motor's receiver.

Step 2: Please select desired channel then to assign the transmitter to communicate with the motor's receiver, push the “UP” and “DOWN” buttons on the transmitter SIMULTANEOUSLY, motor will jog. The ALTUS RTS motor records the address of this transmitter, and only this activated transmitter can be recorded into the memory of the ALTUS motor.

Step 3: Check direction of operation. The “DOWN” button must correspond to BACK on the end-product. In the case of a pergola, it will be closed. If the direction is wrong, change the direction by pressing “MY” button until the motor jogs (3 seconds).

Step 4: Stop the motor at the desired BACK limit position.

Step 5: To set the BACK limit, press the “MY” and “UP” buttons SIMULTANEOUSLY for more than 2 seconds. Release the buttons once the product begins to move towards front of the pergola.

Step 6: Stop the motor at the desired FRONT limit position.

Step 7: To set the FRONT limit, press the “MY” and “DOWN” buttons SIMULTANEOUSLY for more than 2 seconds. Release the buttons once the product begins to move towards back of the pergola.

Step 8: Press “MY” button and the motor will stop.

Step 9: Press “MY” button CONSTANTLY until motor jogs to confirm the settings (5 seconds).

Step 10: Finally, press the “PROGRAMING BUTTON” on the back of the transmitter until the motor jogs (to leave the installation mode).

*Front and Back limit needs to be set for Single Motor (ALTUS 50 RTS) product.

5.5.3. Double Motor

Step 1: Please have a look at the schedule of below diagram.

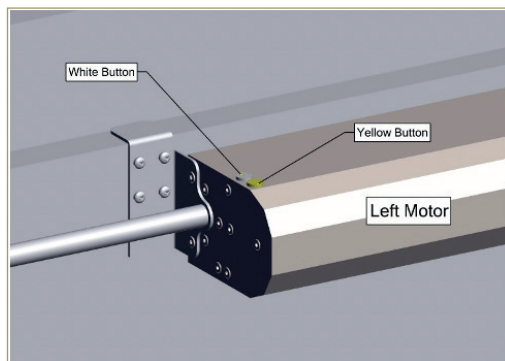
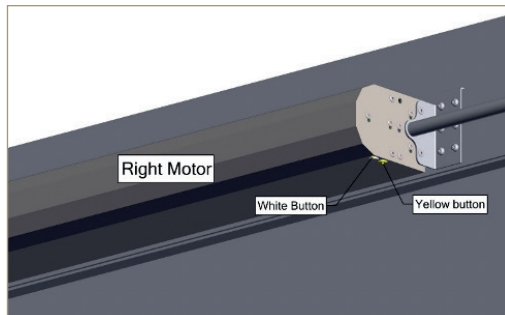
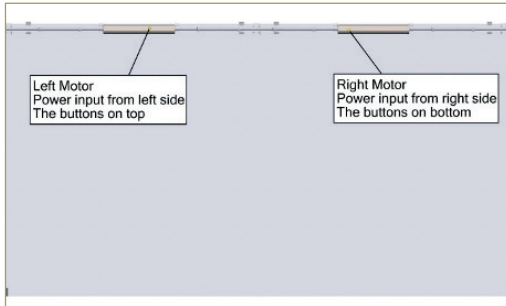

Step 2: Motor power cable must be on the motor control unit box as you see at below picture.

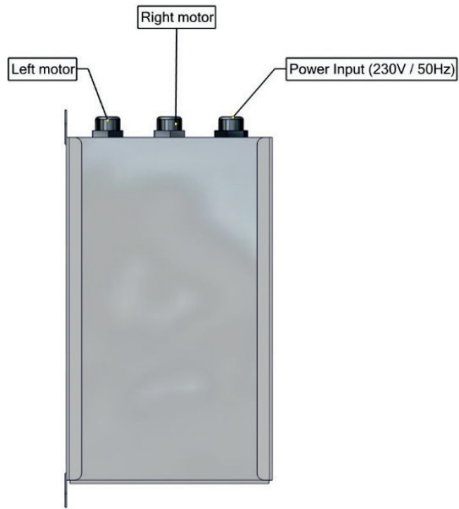

Step 3: Move from "Auto" to "0" button on the control unit box, motor will jog briefly.



Step 4: Choose your desired channel on the Remote control.

Step 5: Remove the cap of the Somfy control unit (Centralis UNO RTS) on the control unit box and press the "PROG" button until the motor jogs to be able to control the motors from the control unit box.



Step 6: Press and hold the PROG button back of the remote control, until motor will jog briefly.

Step 7: Move from "0" to "Auto" button on the control unit box, motor will jog briefly. Now, you can control to motor by your remote control.



Step 8: Right and Left Motor has a switch (Yellow and White). Press both switch buttons on each motor until they lock in the down position (see below).

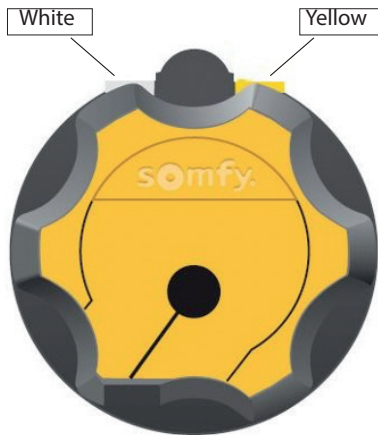

Step 9: Press the down button on remote control until the same align Cross beam reaches the required back position, then stop it.

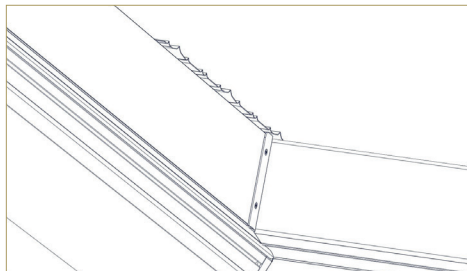

Step 10: Press the down button on remote control until the same align Cross beam reaches the required back position, then stop it.

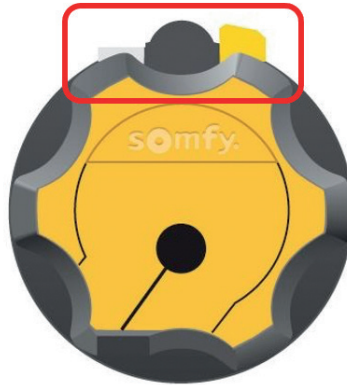

Step 11: Check the back-limit position. If the motors don't stop automatically Yellow button isn't true. You must return the last position to Yellow Button. Correct button is White button. Motor head by pressing and releasing it. The back limit is now set.

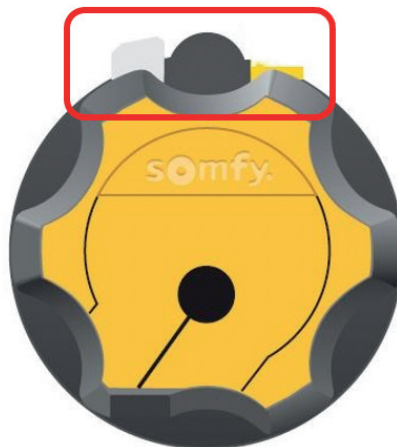

Step 12: Press UP button on your remote control the fabric will be reach to the front beam (Fabric will be stretch). Unlock the FRONT limit switch (White Button) on the just one motor (with same as back limited motor) head by pressing and releasing it. The front limit is now set.

Step 13: Check the front limit position. If the motors don't stop automatically White button isn't true. You must return the last position to White Button. Correct button is Yellow button. Motor head by pressing and releasing it. The front limit is now set.

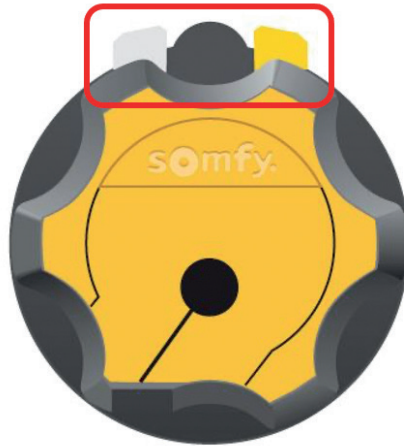

5.5.4. LED Light Control Panel

5.5.4.1. RGB LED Programming

Step 1: Give energy to control box

Step 2: Give energy for at least 4 second and you will hear a click from control box

Step 3: Power off and power on 5 times max. within 5 sec.

Step 4: Leave while power ON. The LED lights will blink within 10 sec.

Step 5: Select a channel from your remote control you desired.

Step 6: Press "PROG" button on remote control at least 2 sec.

- **The lights have stored to desired channel on your transmitter.**

5.5.4.2. Standard LED Programming

Step 1: Give energy to control box

Step 2: Give energy for at least 4 second and you will hear a click from control box

Step 3: Power off and power on 5 times max. within 5 sec.

Step 4: Leave while power ON. The LED lights will blink within 10 sec.

Step 5: Select a channel from your remote control you desired.

Step 6: Press "PROG" button on remote control at least 2 sec.

- **The lights have stored to desired channel on your transmitter.**

5.6. Resetting

5.6.1. Single Motor

Step 1: While provided power to OREA motor unplug for 2 seconds

Step 2: Plug in 10 seconds

Step 3: Unplug 2 seconds

Step 4: Plug in 10 seconds, the OREA motor will jog briefly

Step 5: Press and hold the PROG button on the back of Remote Control for more than 7 seconds until the OREA motor jog briefly 2 times. This removes ALL memorized motor transmitters.

5.6.2. Double Motor

Step 1: Remove the cap of the Somfy control unit (Centralis UNO RTS) on the control unit box and press the "PROG" button around 15 seconds until the motor jogs.

5.6.3. LED Light Control Panel

5.6.3.1. RGB LED Resetting

Step 1: Give energy to control box and wait until red light is on at control box.

Step 1: Power OFF and power ON 10 times max. within 10 sec.

Step 2: Leave while power ON

*** The LED lights will blink within 10 sec. Thus, the lighting control box will be reset.**

- **The RGB lights have deleted on your transmitter.**

5.6.3.2. Standard LED Resetting

Step 1: Give energy to control box and wait until red light is on at control box.

Step 1: Power OFF and power ON 10 times max. within 10 sec.

Step 2: Leave while power ON

*** The LED lights will blink within 10 sec. Thus, the lighting control box will be reset.**

- **The RGB lights have deleted on your transmitter.**

6. SENSORS & AUTOMATION

6.1. Sensors

6.1.1. Single Motor Connection to EOLIS RTS (Wind Sensor)

6.1.1.1. Cabling

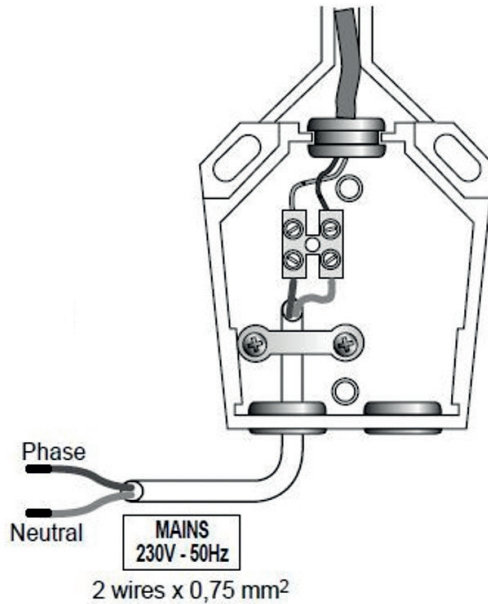

6.1.1.2. Programming

The motor must be in its learning mode to record an EOLIS RTS Sensor.

Up to three EOLIS RTS Sensors can be memorized in a motor and one EOLIS RTS Sensor can be memorized in several motors.

- Enter the "learning" mode;
 - Press more than 2 seconds on the programming button of a RTS control which is already memorized in the motor.
 - Press briefly on the "prog" button of the EOLIS RTS Sensor.
 - The pergola moves shortly (DOWN/UP).
- Record or delete a sensor;
 - Press briefly on the "prog" button of the EOLIS sensor RTS.
 - The pergola moves shortly (DOWN/UP).

- Erase all the sensors and record a new one;
 - Press more than 7 sec. on the “prog” button of the new EOLIS RTS sensor.
 - The pergola moves shortly (DOWN/UP)

6.1.1.3. Functioning

The WIND threshold can be adjusted by a potentiometer accommodate wind speed between 10 to 50km/h (6 to 31mph)

- When the wind speed exceeds the threshold set by the EOLIS sensor RTS, an UP order is given to the pergola after 2 sec.
- As long as the measured wind speed is higher than the adjusted threshold, any order is inhibited.
- When the wind speed falls below the threshold setting, an order can be given with the RTS control after 30 sec.

6.1.2. Single Motor Connection to SOLIRIS RTS (Sun and Wind Sensor)

On Orea RTS Motor connection to SOLIRIS RTS (Sun & Wind Sensor).

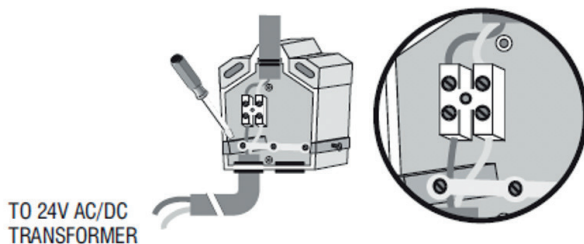

6.1.2.1. Programming

- The motor must be in programming mode to record a SOLIRIS RTS Sensor
- One SOLIRIS RTS Sensor can be memorized into several motors.
- It isn't recommended to memorize more than 1 SOLIRIS RTS Sensor into motor's memory.
- To Enter the Programming mode;
 - Activate the receiver's memory by pushing (for more than 2 seconds) the programming button of a transmitter already recorded in the motor's memory.
- To Record or delete a sensor ;
 - Press briefly on the programming button of the SOLIRIS RTS briefly sensor.
- To delete all the sensors and record a new one;
 - Press for more than 7 sec. on the “programming” button of the new SOLIRIS RTS.

6.1.2.3 Operation

The SOLIRIS RTS Sensor controls and provides a measure of protection for a retractable pergola according to the sun and wind conditions. The WIND and SUN thresholds can be adjusted by two potentiometers, one for wind speed and the other for daylight intensity.

The adjustment range is between 10 – 50 km/h (6 – 31 mph) for the WIND and between 0 to 50 kilolux for the SUN.

By using the SOLIRIS RTS Sensor it is possible to configure the functioning of the receiver (wind only or wind/sun). Please refer TELIS SOLIRIS RTS to the operating instructions.

A short UP/DOWN movement of the retractable pergola indicates the modification of the sensor settings.

6.1.2.4 Single or Tandem System Connection to SUNIS (Sun) Sensor

• **IMPORTANT REMARKS BEFORE INSTALLATION**

- Expose the sensor 20min. to the daylight to initialize its autonomous system (put the cells under the maximum daylight intensity).
- To verify charging level of sensor, press briefly the Mode button: if LED lights=ready for use.

• **FEATURES**

- Up to 3 sensors can be memorized in one motor, it could be combined with other RTS sensors (EOLIS RTS, SOLIRIS RTS)
- One Sunis sensor RTS can be memorized in several motors
- Supply: "SOLAR"
- Autonomy: 24 hours without new daylight intensity.

• **PROGRAMMATION**

- To proceed to programming, sensor must be charged (refer to important remarks before installation step).
- Enter the "Programming" Mode.
- By pressing > 2 sec. PROG. button of Remote Control (for single motor) or Centralis (for tandem system) until motor feedback.
- Record a sensor.
- By pressing briefly PROG. Button of sensor until motor feedback.

SETTING INSTRUCTIONS

LED reaction in "DEMO" mode or "USER" mode. Enter the "DEMO" mode.

THRESHOLD	USER MODE	DEMO MODE
Under sun level: RED LED	Continues light during 5 sec.	Blinking light during 30 sec.
Over sun level: GREEN LED	Continues light during 5 sec.	Blinking light during 30 sec.

By pressing MODE button > 2 sec. > the light will start blinking for 30 sec. + feedback motor.

- Adjust the sun threshold with the potentiometer.

The blinking led will be green once you have reached the current sun level.

The level you set will be the one to set off the sun function

- Verify the functioning.

Let the demo mode works (if no sun, use a lamp)

- Enter the "USER" mode.

By pressing MODE button > 2 sec. > feedback motor

- DEMO mode will move back automatically after 3 min. in USER mode.

• MOUNTING INSTRUCTIONS

- o Make sure to install sensor vertically and in place where solar cells can catch daylight intensity.
- o Sensor delivered without screws, use the screw adapted to your wall support.

SUN FUNCTIONING

Use the Telis with sun function to activate or deactivate the sun function (Telis Soliris RTS, Telis Modulis Soliris RTS.)

Manual Mode: Sun function deactivated.

Automatic mode: Sun function activated.

• Sun appearing

When the intensity of the daylight exceeds the threshold set by the Sunis sensor RTS, a Down order is sent to the blind after 2 mins. The blind goes to the MY position or to its down end limit position if no My position has been memorized.

• Sun disappearing

When the daylight level fails below the threshold setting, a variable time delay from 12-30 mins. is activated (depending on the sun presence duration). After this time delay, an UP order is given to the blind.

READJUSTING

ADJUST THE SUN LEVEL WITH THE POTENTIOMETER ACCORDING TO YOUR WISHES	
1 turn to left (-)	2 Turn to right (+)
LESS sun is needed to lower the blind	MORE sun is needed to lower the blind

6.1.3. Single Motor Connection to ONDEIS (Rain) Sensor

Rain sensor requires a dry contact input. Our single motors (OREA or ALTUS) works with RTS. Therefore, there isn't any dry contact output.

In this case, you must supply "Dry contact Transmitter" which works only for one motor. If there are up to 5 motors you must supply "RS485".

6.1.4. Tandem System Connection to EOLIS or SOLIRIS Sensor

We use the Universal RTS Receiver on Tandem motors system. The Universal receiver RTS is compatible with all standard SOMFY wired motors. Cabling arrangements are shown in the diagram. Up to 3 sensors can be memorized to one receiver to optimize weather detection and up to 12 transmitters can be recorded.

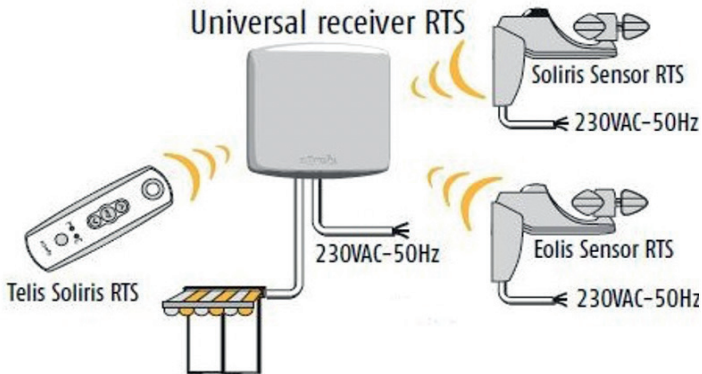

Dry contact transmitter: ELK.SMF.G1000.0047
RS485: ELK.SMF.G1000.0011

6.1.4.1. Universal Receiver RTS Inside Description

1. Prog. LED
2. Prog button
3. Test button
4. Sensor live (brown)
5. Sensor neutral (blue)
6. Power supply live (brown)
7. Power supply neutral (blue)
8. Motor common
9. Motor DOWN
10. Motor UP
11. Power supply earth (yellow/green)
12. Motor earth (yellow/green)

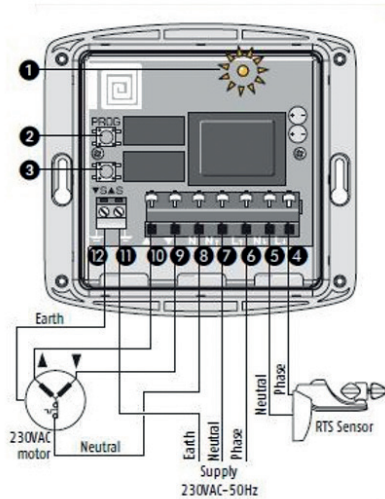

6.1.4.2. Programming

- Installing or Removing a Transmitter;
 - Enter Programming Mode;
 - Press the programming button of the Universal Receiver -> 2sec until the motor feedback and LED lights.
- Record/Delete the transmitter;
 - Press briefly prog button on the back of the transmitter -> motor feedback / LED of receiver blinks.
- Installing or Removing a Sensor;

- Enter Programming Mode;
- Press the programming button of the Universal Receiver -> 2sec until the motor feedback and LED lights.
- Record/Delete the transmitter;
 - Press briefly prog button of the sensor -> motor feedback / LED of receiver blinks.
- Removing all the controls and the sensors from the memory of the receiver.
 - Press the programming button of the Universal Receiver -> 7 sec until blinking of the LED and 2 motor feedbacks.

6.1.5. Tandem Systems Connection to ONDEIS (Rain) Sensor

Rain sensor requires a dry contact input. Our tandem systems have a synchronizing control unit box. That box ensures that both motors works simultaneously.

Also, these motors not RTS motors. That's why there is Centralis. The Centralis ensures that communication between transmitter and synchronizing control unit box. But it can't communicate between rain sensor and synchronizing control unit box. The ONDEIS rain sensor can send a signal as dry contact signal.

In order to use ONDEIS rain sensor you must use Dry contact transmitter. That's why you must change Centralis with UNIVERSAL RECEIVER RTS in Synchronizing control unit box.

The Universal Receiver RTS can communicate with dry contact transmitter or RS485 (multiple dry contact transmitter. Up to 5 channels.) Then dry contact transmitter communicates with ONDEIS Rain Sensor and also synchronizing control unit box.

The Ondeis rain sensor has a two-cable output. One cable must go to main voltage (230V/50Hz) and other is dry contact signal cable. You must connect rain sensor dry contact cable to RS485's channel input jacks (from 1 to 5).

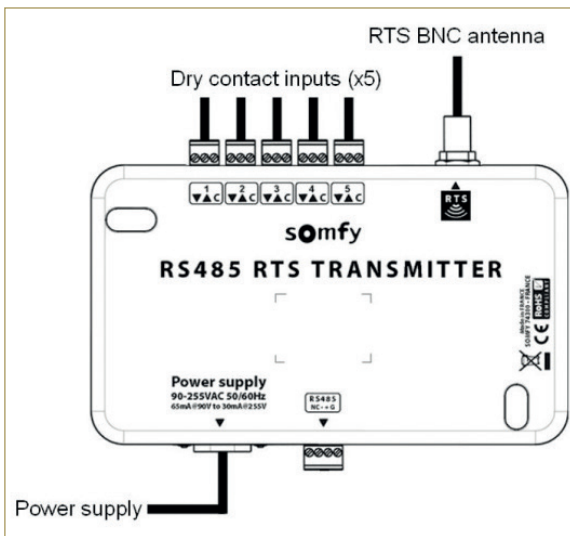

When you plug all cables now you can program to rain sensor.

- Select the RTS address on the channel selector corresponding to dry contact connectors.

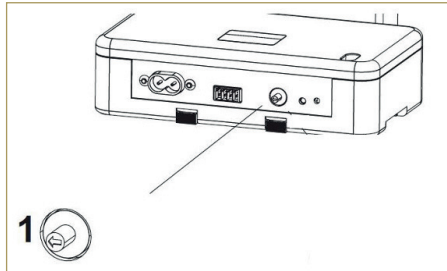

- Press to PROG button on your remote control.
 - Then press PROG button on RS485 or Dry Contact Transmitter.
- If you supplied any time (after order or installation) you can change it.

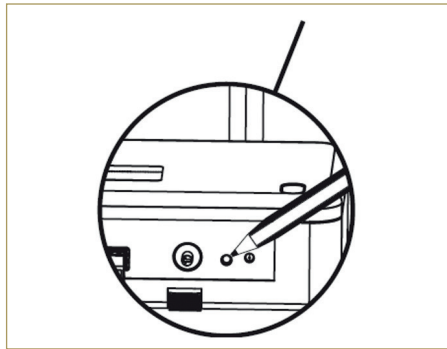

- Red cable to no:1

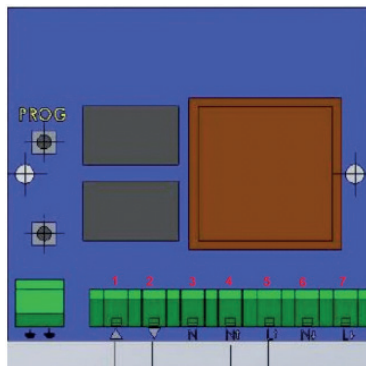

- Black cable to no:2
- Blue cable no:3
- Neutral: Blue cable no:4
- Phase: Red cable no:5

If you have ONDEIS Rain sensor you must inform before the order. Then Palmiye will send Universal Receiver RTS instead of Centralis UNO RTS on during the production.

6.2. Automation

6.2.1. Adaptable to Somfy Systems

Our Retractable Pergola Systems can be controlled by Somfy Home Automation Smart System which is CONNEXOON® Window RTS.

You can download from below link:

For IOS system:

<https://apps.apple.com/tr/app/connexoon-window-rts/id1168009218?l=tr>

For ANDROID system:

https://play.google.com/store/apps/details?id=com.somfy.connexoon_window&gl=TR

- The retractable pergola system motors can control by CONNEXOON® Window RTS application on smart phone.
- CONNEXOON® Window RTS device has to connect to the Ethernet modem connection.
- Download it,
- Create an account,
- Log in to the system,
- Enter the pin code which is below of the Connexoon transmitter,
- Read and Skip information tabs,
- Click 3 line on left top,
- Click configuration,
- Click (+) add button,
- Select your product,
- Program to your product,
- Give a name to your product,
- Now, you can control by your smart phone.

6.2.2. Adaptable To Other Automation Systems

In order to connect to different automation home smart system, there is RS485 RTS Transmitter or Dry Contact Transmitter.

- Only RTS motors can be controlled by RS485 RTS Transmitter or Dry Contact Transmitter.
- RS485 have a 5 dry contact input and Dry Contact Transmitter have only one input.
- Select the RTS address on the Channel selector corresponding to dry contact connectors.
 - The dry contact connector n°1 has per default, the RTS address n°1
 - The dry contact connector n°2 has per default, the RTS address n°2
 - The dry contact connector n°3 has per default, the RTS address n°3
 - The dry contact connector n°4 has per default, the RTS address n°4
 - The dry contact connector n°5 has per default, the RTS address n°5
- Press the programming button on the back of the RTS control point or the RTS receiver until the motor jogs.

The product is in programming mode.

- Press the programming button on the RS485 RTS transmitter or Dry contact Transmitter until the motor jogs.

The product is assigned to the transmitter.

- It can up to 16 groups of Somfy RTS motors and receivers.
- Press the programming button on the back of the RTS control point or the RTS receiver until the motor jogs.

The product is in programming mode.

- Send by the RS485 control or Dry Contact Transmitter, the corresponding RTS frame on the desired channel.

The product is assigned to the transmitter's channel with a motor jog.

- It is impossible to set a motor or receiver with this RS485 RTS transmitter or Dry Contact Transmitter.

7. HARDWARE

7.1. Back Beam - Back Pillar Connection

M12x185mm countersunk head bolt

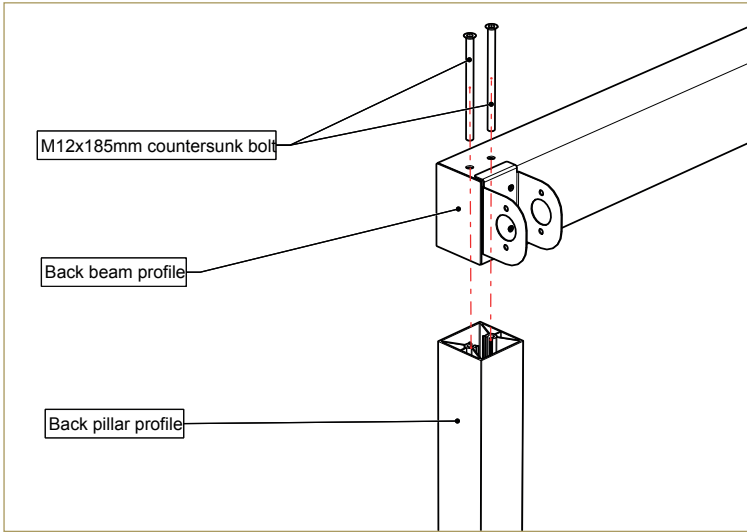

7.2. Rail - Back Beam Connection

M8x16mm hexagonal head stainless steel bolt

M8 stainless steel washer

M8 stainless steel nut

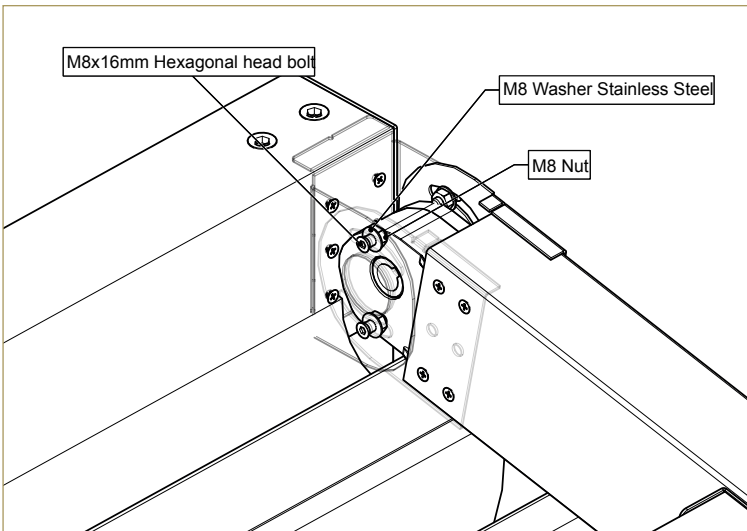

7.3. Rail – Front Beam Connection

M4.8x25mm self-drilling screw

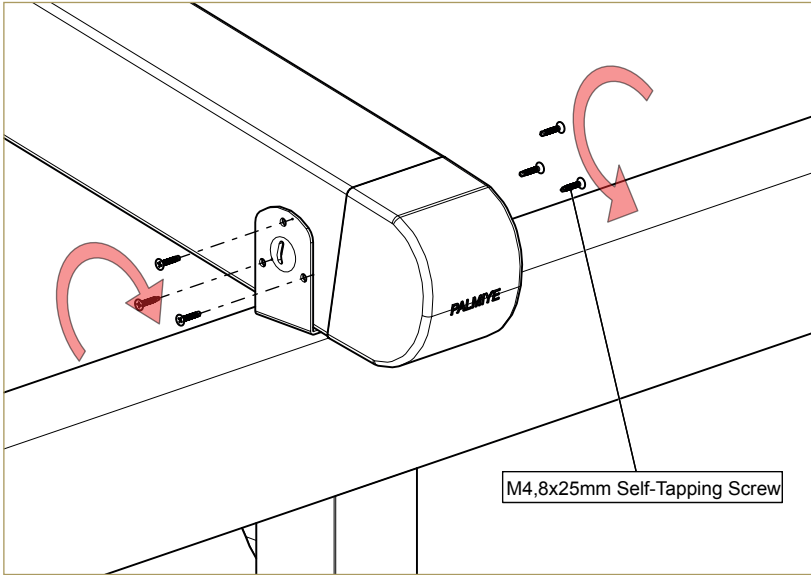

7.4. Pillar – Front Beam Connection

M10x160mm hexagonal head dacromented bolt

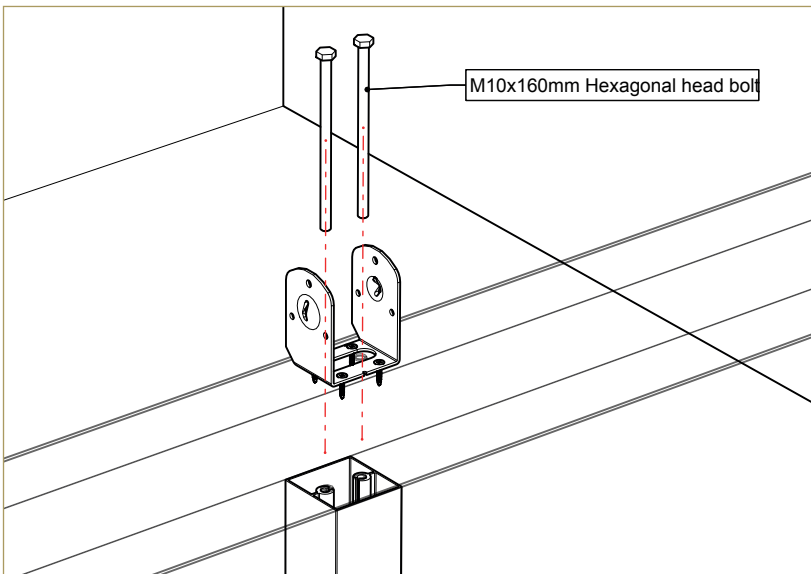

7.5. Pillar – Ground Connection

M12x200mm Galvanized Rod

M12 Stainless Steel Washer

M12 Stainless Steel Nut

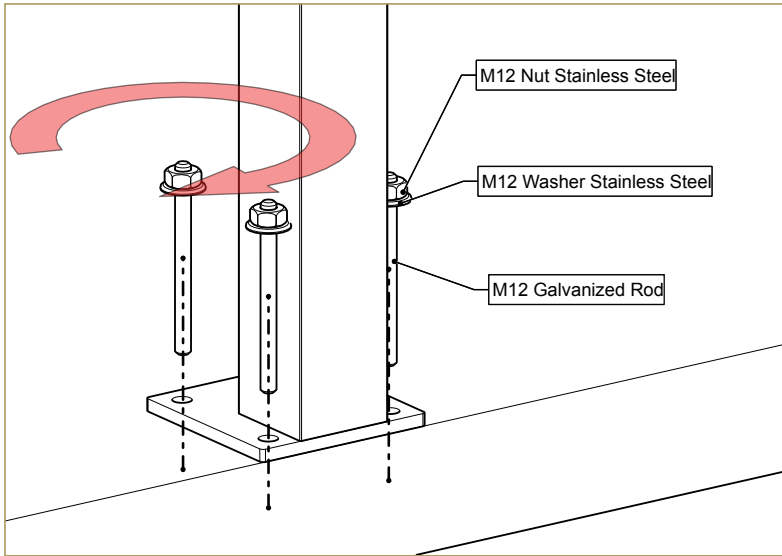

7.6. Motor – Back Beam Connection

M5.5x25mm self-drilling screw with washer

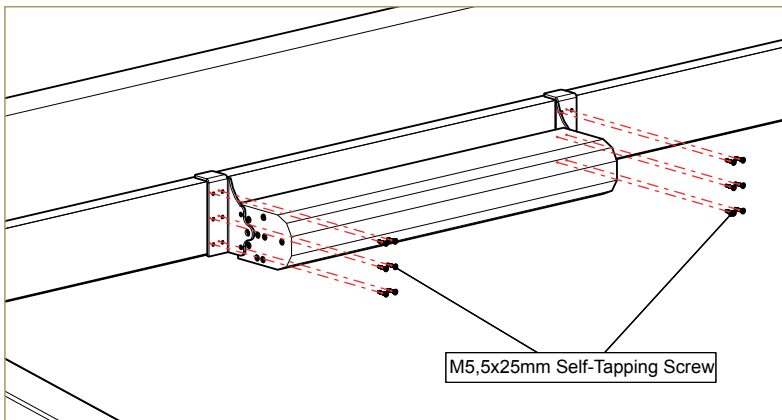

7.7. Fabric – Carrier Connection

M8 nut with sealant.

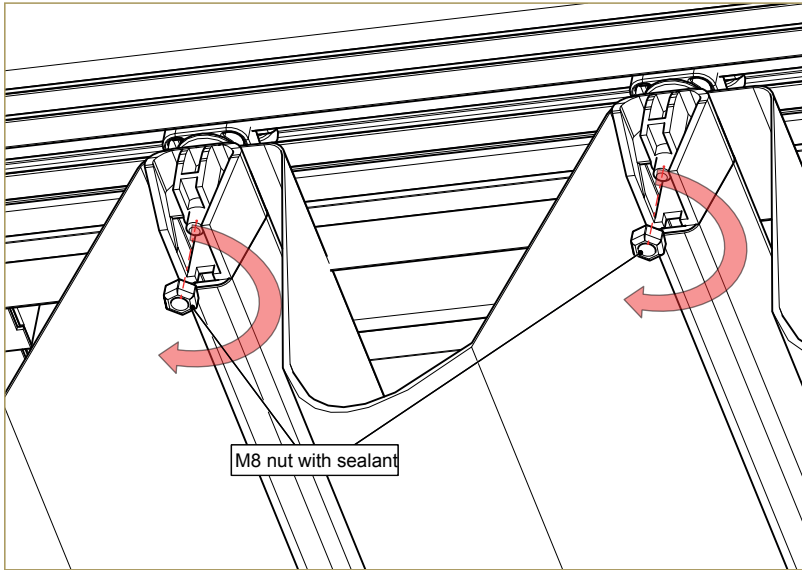

7.8. Gutter – Front Beam Connection

M5.5x25mm self-tapping screw with washer.

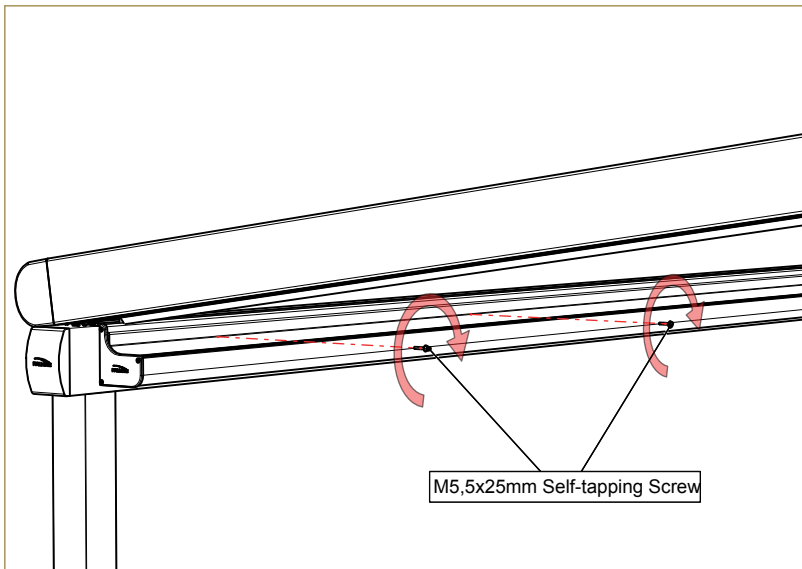

7.9. Side Beam – Front Beam Connection

M4.8x25mm self-drilling screw.

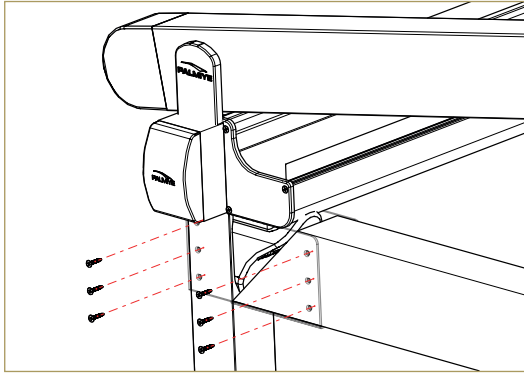

7.10. Side Beam – Back Pillar Connection

M4.8x25mm self-drilling screw

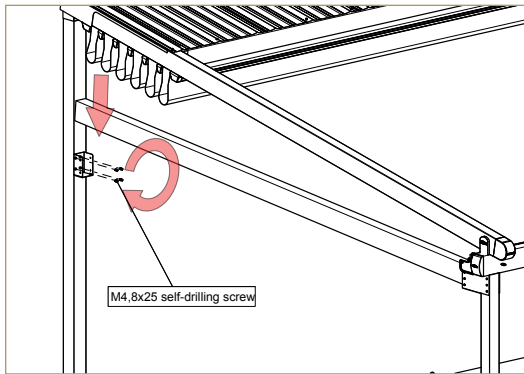

M4.8x25mm self-drilling screw

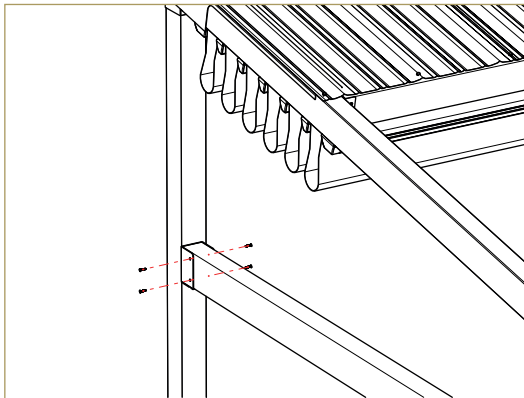

7.11. Side Beam – Side Beam Pillar Connection

M4.8x25mm self-drilling screw.

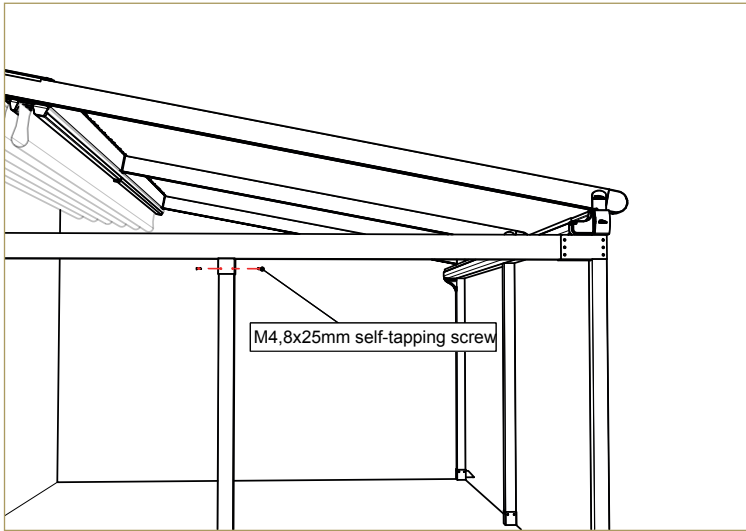

7.12. Cross Beam – Rail Connection

M4.8x25mm self-tapping screw.

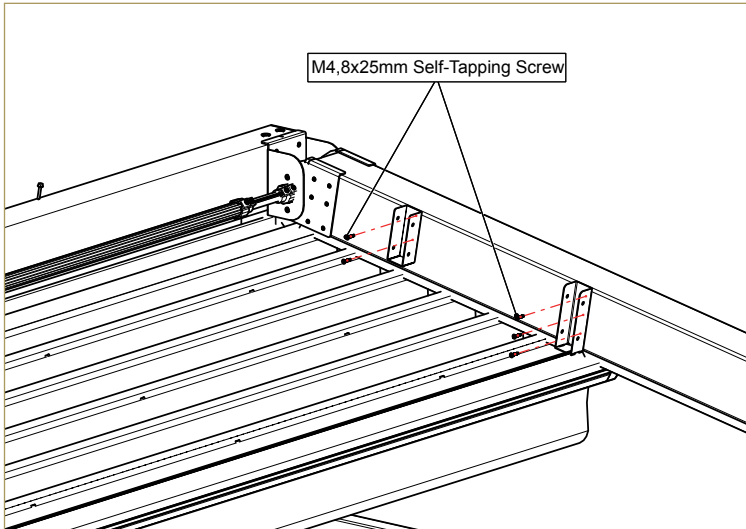

M4.8x25mm self-tapping screw.

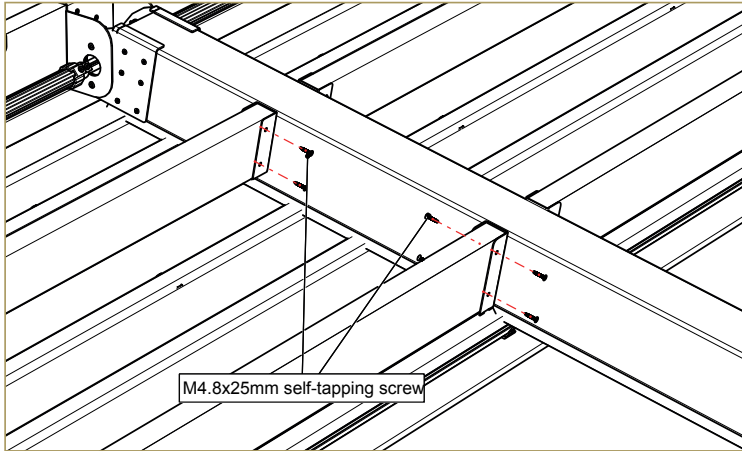

7.13. Fabric Cover Sheet – Cross Beam Connection

M5.5x25mm self-drilling screw with washer.

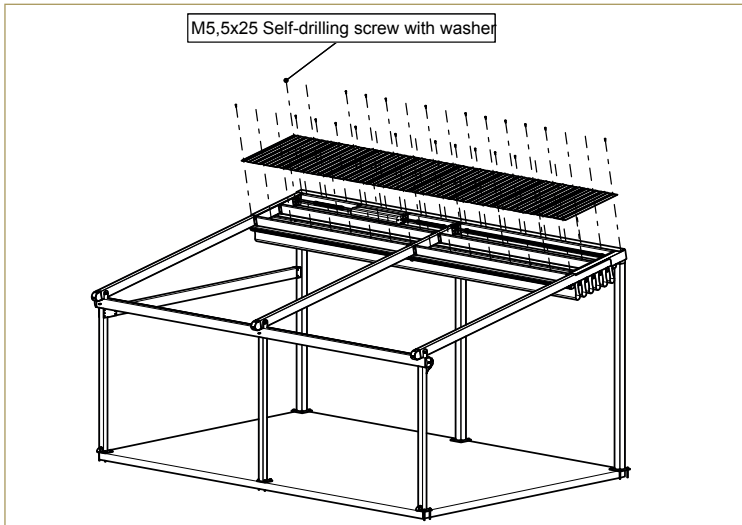

8. TOOLS

Image	Product	Description	Product Code
	Fabric Elevator	To lift up ready-to-fix Fabric to Rails	DMR.APR.G1107.YMMX
	Fabric Stretch Apparatus	to stretch fabric and fix the fabric support profiles	DMR.APR.G1106.YMMX
	Fabric hole cutter	to open hole on fabric after fixing the fabric support profiles	HRD.TKM.G1039.BRUT
	Gutter Drainage Hole Bending Apparatus (ø70mm)	to bend the drainage hole on gutter which is making on site	DMR.APR.P1066.ELGV
	Gutter Drainage Hole Bending Apparatus (ø50mm)	to bend the drainage hole on gutter which is making on site	DMR.APR.P1067.ELGV
	Palmiye T-Shirt	for Installation teams	HZM.ISG.G1009BRUT
	Palmiye Trousers	for Installation teams	HZM.ISG.G1014.BRUT
	Palmiye Waistcoat	for Installation teams	HZM.ISG.1013.BRUT
	Sealant NP1 Dark Brown	to block the passage of water through the surface or joints or openings in materials	HRD.KMY.C0018.KAHV
	Sealant NP1 Light Brown	to block the passage of water through the surface or joints or openings in materials	HRD.KMY.C0018.AKAH
	Sealant (Black)	to block the passage of water through the surface or joints or openings in materials	HRD.KMY.G0016.SYAH
	Sealant (White)	to block the passage of water through the surface or joints or openings in materials	HRD.KMY.G0017.BYAZ
	Sealant (Grey)	to block the passage of water through the surface or joints or openings in materials	HRD.KMY.G0022.GREY

Image	Product	Description	Product Code
	Epoxy	to anchor rods to concrete	HRD.KMY.G1027.BRUT
	M12 Rod	to fix and stabilize products to ground/wall/ceiling	HRD.CVT.G0100.ZINC
	M30 - Rod Galvanized	to fix and stabilize products to ground/wall/ceiling	HRD.CVT.G0105.ZINC
	M12 Rondela Washer - Stainless Steel	part to fix and stabilize products to ground/wall/ceiling	HRD.CVT.G1062.PSMZ
	M12 Washer Stainless Steel	part to fix and stabilize products to ground/wall/ceiling	HRD.PUL.G0003.PSMZ
	M30 Washer - Galvanized	part to fix and stabilize products to ground/wall/ceiling	HRD.PUwG0014.ZINC
	M12 Acorn Nut	part to fix and stabilize products to ground/wall/ceiling	HRD.SMN.G0008.ZINC
	M12 Nut Stainless Steel	part to fix and stabilize products to ground/wall/ceiling	HRD.SMN.G0011.PSMZ
	M30 Nut - Galvanized	part to fix and stabilize products to ground/wall/ceiling	HRD.SMN.G0022.ZINC

INSTALLATION TOOL LIST

	Tool box with wheel	1 pc
	Spiral grinder	1 pc
	Batery driller.	1 pc
	Electric impact drill	1 pc
	Lighting	2 pc
	Extansion lead	2 pc
	Ladder	2 pc
	Tape measure 5m	1 pc
	Tape measure 10m	1 pc
	Water gauge	2 pc
	Laser Meter	1 pc
	35 cm angle	1 pc
	Wrench Set	2 Set
	Flush Cutter	2 pc
	Pliers	2 pc

	Allen wrench set	2 Set
	Socket wrench	1 pc
	Screw driver	1 Set
	Plastic hammer	1 pc
	Iron hammer	2 pc
	Electrical screw driver	2 pc
	Cutter	1 pc
	Silicon gun	2 pc
	Bits	2 Set
	PH2X100 Bits	2 pc
	APEX 493 A Bits	2 pc
	Insulating Tape (Black)	6 pc
	Insulating Tape (White)	6 pc
	Glue	2 pc
	Punch driller 70 mm	2 pc
	Guide drill bit	1 set

9. FREQUENTLY ASKED QUESTIONS

Problem	Reason	Solutions
The motor wouldn't start	There is no electricity	Check the electric current.
	It is not plugged in.	Check that the plug is correctly connected to a suitable socket.
	The motor has overheated and led on the control panel is lit.	Wait 5-10 minutes to allow the motor to cool down. If the problem persists check the limit switch
	Depleted remote control batteries	Change the remote battery
	Broken fuse	Open the control panel and change the fuse
The motor starts but the pergola won't move	Possibly broken belts, or disconnection from drive shaft.	Contact Palmiye
The pergola moves erratically	Dirty rails, rails not properly aligned.	Clean the rails. Follow instructions in chapter on maintenance. Realign the rails.
Lights are not on	Not all lights are on	Check the electric current.
	Part of the lights are not on	LEDs whose lights are not lit up.
Gutter overflow	Gutter overflow	Clean the gutter and elbow
The product leaks water	The product isolation leaks water	Make sure that area of the system water tightness gaskets is clean (leaves, branches, etc.)
		Contact Palmiye

10. RISK TABLE

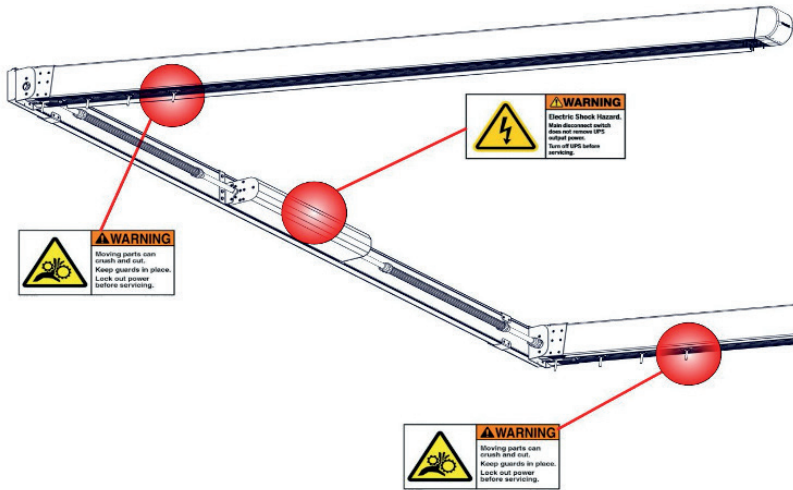

11. MOTORIZATION

According to retractable pergola size; single and double motors are used.

11.1. Single Motor

Somfy Orea 60 RTS motors are used on 230VAC/50Hz using electricity countries. Somfy LT60 Altus RTS motors are able to uses on 120VAC/60Hz using electricity countries.

They are controlling by remote control device

		Nominal Torque	Nominal Speed	Rated Power	Rated Current	Thermal Tripping	Noise
230VAC / 50Hz	OREA 60	55Nm	17rpm	290W	1,25A	130°C	64dBA
		85Nm	17rpm	400W	1,8A	140°C	66dBA
		120Nm	12rpm	400W	1,8A	140°C	65dBA
120VAC / 60Hz	LT60 ALTUS	60Nm (530in. lbs.)	14rpm	300W	2,5A	4 min.	63dBA
		80Nm (700in. lbs.)	14rpm	400W	3,4A	4 min.	65dBA
		100Nm (880in. lbs.)	14rpm	450W	3,8A	4 min.	67dBA

11.2. Double Motor

Somfy LT60 WT motors are used in countries using 230VAC/50Hz electricity. Somfy LT60 STANDARD WT motors are used in countries using 120VAC/60Hz electricity.

Systems are controlled by remote control devices over control box.

		Nominal Torque	Nominal Speed	Rated Power	Rated Current	Thermal Tripping	Noise
230VAC / 50Hz	LT60 (Orion S)	55Nm	17rpm	320W	1,5A	150°C	64dBA
	LT60 (Jupiter)	85Nm	17rpm	450W	2,1A	150°C	65dBA
	LT60 (Taurus)	120Nm	12rpm	450W	2,1A	150°C	65dBA
120VAC / 60Hz	LT60 ALTUS	60Nm (530in. lbs.)	14rpm	300W	2,5A	5 min.	63dBA
		80Nm (700in. lbs.)	14rpm	400W	3,4A	5 min.	65dBA
		100Nm (880in. lbs.)	14rpm	450W	3,8A	5 min.	67dBA



www.palmiye.eu



PALMIYE
Four Seasons Outdoor Living Areas

The logo features a stylized graphic of a palm frond or a curved line above the brand name. The brand name 'PALMIYE' is in a bold, uppercase, sans-serif font. Below it, the tagline 'Four Seasons Outdoor Living Areas' is written in a smaller, lowercase, sans-serif font.